

SCHEDULE 22 – COMMON CONNECTION CHARGING METHODOLOGY

Introduction

1. This Schedule 22 sets out the Common Connection Charging Methodology (CCCM). The CCCM is the whole of this Schedule 22 excluding only this introductory section.
2. Each DNO Party is obliged by Standard Licence Condition 13 to have a connection charging methodology in force (each a **Connection Charging Methodology**). Each DNO Party is obliged by Standard Licence Condition 13 to include the CCCM within its Connection Charging Methodology.
3. The DNO Party will include within the document containing its Connection Charging Methodology other matters which are outside the scope of the CCCM.
4. The CCCM is split into two sections numbered ‘1’ and ‘2’, and refers to other sections of the document in which the CCCM is to be included. When each DNO Party includes the CCCM within the document containing its Connection Charging Methodology, the DNO Party shall replace such section numbering and cross-references with the section numbers and cross-references appropriate for its document.
5. Modifications to this Schedule 22 are governed by the provisions of this Agreement.
6. The glossary forming part of the CCCM contains definitions of terms and acronyms used in the CCCM. In the case of any conflict between the defined terms and acronyms set out in the CCCM (on the one hand) and the definitions and rules of interpretation set out in Clause 1 of this Agreement (on the other), the defined terms and acronyms set out in the CCCM shall prevail for the purposes of the CCCM.

Common Connection Charging Methodology

Section 1 – Common Connection Charging Methodology

This Section sets out the Common Connection Charging Methodology that is implemented to ensure a consistent approach in the way your Connection Charge is calculated.

1.

Minimum Scheme

1.1 The Minimum Scheme is the Scheme with the lowest overall capital cost (as estimated by us), solely to provide the Required Capacity. The Minimum Scheme will be subject to:

- accepted industry standards, including the requirements of the Distribution Code;
- the status and configuration of the Relevant Section of Network (RSN);
- the standard sizes and types of equipment currently used by us on our Distribution System which shall be reasonable in all the circumstances;
- maintaining our ability to minimise regulatory penalties associated with the Interruptions Incentive Scheme and the Guaranteed Standards of Performance; and
- where the Customer is an LDNO, maintaining the Customer's ability to minimise regulatory penalties associated with the Guaranteed Standards of Performance,

and shall be consistent with our statutory and licence obligations including the requirement to develop, maintain and operate an efficient, co-ordinated and economical electricity Distribution System.

1.2 We will make available our design policies and standards as appropriate.

1.3 Subject to paragraphs 1.4 and 1.7 below, we will calculate the Connection Charge based on the estimated costs of the Minimum Scheme.

1.4 In certain circumstances we may decide to design an Enhanced Scheme. This will include one or more of the following:

- additional assets not required as part of the Minimum Scheme;

- assets of a larger capacity than required by the Minimum Scheme;
 - assets of a different specification than required by the Minimum Scheme.
- 1.5 If we decide to design an Enhanced Scheme, the Connection Charge that will apply will be the lower of the Connection Charge associated with the Minimum Scheme and the Connection Charge associated with the Enhanced Scheme.
- 1.6 The Connection Charge associated with the Enhanced Scheme will be calculated subject to the exclusion of costs of any additional assets not necessary for the provision of your connection.
- 1.7 We may recover the reasonable costs incurred, both direct and indirect, in providing a connection and may, where allowed by our Licence, apply a margin on some of those costs. The factors taken into account by us to calculate the Connection Charge will include, but are not limited to:
- industry standards governing the Distribution System;
 - the Required Capacity;
 - available capacity of the existing Distribution System;
 - whether any necessary extension or Reinforcement of the existing Distribution System is by underground cable or overhead lines;
 - whether any diversionary work is required as a result of the development and the required disconnection of any assets;
 - the length of cable or line required;
 - type of ground requiring excavation, the type and extent of reinstatement necessary (including New Roads and Street Works Act requirements and any other relevant legislation), and the need for road, bridge crossings etc;
 - any Electrical Plant and civil costs required, allowing for any civil works undertaken by you with our agreement;
 - the cost of installing communication equipment;

- the costs of installing system management equipment;
- the requirement to work outside of normal working hours;
- the costs of undertaking the design;
- the costs of securing wayleaves/easements for plant, cables or lines including any consents;
- the costs of securing suitable substation sites including any necessary Land Rights;
- any overhead line surveys required;
- the costs of public enquiries and environmental impact studies;
- charges for any other costs associated with the work on Sites of Special Scientific Interest (SSSI), railway lines etc; and
- any variations in respect of the actual costs that were reasonably incurred as specified in the Connection Offer.

Cost Allocation

1.8 The costs to be charged to you as a Connection Charge may be split into three categories:

- Costs for providing the connection which are to be paid in full by you (see paragraphs 1.10 to 1.16);
- Costs for providing the connection which are to be apportioned between you and us (see paragraphs 1.28 to 1.33); and
- Costs to be paid by you in respect of works that have previously been constructed or are committed and are used to provide the connection (see paragraph 1.34).

1.9 Some costs may be borne in full by us and will not be included in your Connection Charge (see paragraphs 1.35 to 1.39).

Costs to be paid in full by you

1.10 The costs of providing Extension Assets are charged in full to you.

- 1.11 Where you have requirements for additional security or the characteristics of your load requires us to install assets in excess of the Minimum Scheme then you will pay the costs in excess of the Minimum Scheme in full. Where you have requested a three-phase connection and/or a supply voltage that is not necessary to meet the Required Capacity, and the local Distribution System is not of the requested number of phases and/or voltage, then you will pay in full the cost of Reinforcement of the Distribution System to your specified number of phases and/or voltage.
- 1.12 The costs of the future operation and maintenance of any additional assets requested by you (over and above those associated with the Minimum Scheme) will be payable in full. This would normally be levied as a one-off charge representing the net present value of the future operation and maintenance costs and calculated as a percentage (specified in Section [6]) of the additional capital cost of the Scheme. See Example 7 for an illustration of where you request additional security.
- 1.13 Work required to reconfigure the Distribution System to meet your requirements where no additional Network or Fault Level Capacity is made available shall be charged in full to you. See Example 20.
- 1.14 Where the Extension Assets would normally require the extension of existing switchgear equipment and this is not possible, the cost of the full replacement of the switchgear (using the nearest standard size) will be charged to you, provided that there is no Reinforcement of the Distribution System (see paragraph 1.25).
- 1.15 If your development is considered to be speculative then the Reinforcement costs will be charged to you in full (see paragraphs 1.48 to 1.70).
- 1.16 Reinforcement costs for the Minimum Scheme in excess of the High-Cost Project Threshold, shall be charged to you in full as a Connection Charge. For the avoidance of doubt, where Paragraph 1.36 applies, the High-Cost Project Threshold will not apply. The calculation of this charge will include all costs for Reinforcement carried out at the same Voltage Level and one Voltage Level above the Point of Connection to the existing Distribution System. For Generation Connections the High-Cost Project Threshold is £200/kW; for Demand Connections the High-Cost Project Threshold is £1,720/kVA. Reinforcement costs up to and including the High-Cost Project Threshold will follow the methodology outlined under paragraphs 1.17 to 1.27. For Generation Connections, where

the Reinforcement costs at the same Voltage Level as the Point of Connection are greater than the High-Cost Project Threshold then the methodology outlined under paragraphs 1.17 to 1.27 will be applied to Reinforcement costs up to and including the High-Cost Project Threshold only. The table below illustrates the application of the High-Cost Project Threshold.

England and Wales

Voltage of Scheme Assets	Voltage at the POC			
	LV (at or below 1000V)	HV (above 1kV but not more than 22kV)	EHV (above 22kV but not more than 72kV)	132kV
132kV Network	Excluded from assessment ¹	Excluded from assessment ¹	Included in assessment	Included in assessment
132kV/ EHV Substation	Excluded from assessment ²	EHV CBs only included in assessment	Included in assessment	Not applicable
EHV Network	Excluded from assessment ¹	Included in assessment	Included in assessment	
132kV/ HV Substation	HV CBs only included in assessment	Included in assessment	Not applicable	
EHV/HV Substation	HV CBs only included in assessment	Included in assessment		
EHV/LV substation	Included in assessment	Not applicable		
HV Network	Included in assessment	Included in assessment		
HV/ LV Substation	Included in assessment	Not applicable		
LV Network	Included in assessment			

¹ Except where there is direct transformation from 132kV to HV or EHV to LV when the higher voltage costs are included.

² Except where there is direct transformation from 132kV to HV or EHV to LV when the higher voltage circuit breaker costs are included.

NB: The above table may not accommodate every possible set of circumstances, where this is the case, the Voltage Level (as defined in the Glossary) shall be applied.

Scotland

Voltage of Scheme Assets	Voltage at the POC		
	LV (at or below 1000V)	HV (above 1kV but not more than 22kV)	EHV (above 22kV but not more than 72kV)
EHV Network	Excluded from assessment ¹	Included in assessment	Included in assessment
EHV/HV Substation	HV CBs only included in assessment	Included in assessment	Not applicable
EHV/LV substation	Included in assessment	Not applicable	
HV Network	Included in assessment	Included in assessment	
HV/ LV Substation	Included in assessment	Not applicable	
LV Network	Included in assessment	Not applicable	

¹ Except where there is direct transformation from EHV to LV when the higher voltage costs are included.

NB: The above table may not accommodate every possible set of circumstances, where this is the case, the Voltage Level (as defined in the Glossary) shall be applied.

Costs of Reinforcement

1.17 Reinforcement is defined as assets installed that add capacity (network or fault level) to the existing shared use Distribution System.

1.18 For Generation Connections, where the Reinforcement is at the same Voltage Level as the voltage at the POC to the existing Distribution System, then the costs of

Reinforcement shall be apportioned between you and us, unless other exceptions apply which take precedence. The methods used to apportion the costs of Reinforcement are set out in paragraphs 1.28 – 1.33. Where the Reinforcement costs at the Voltage Level of the POC are greater than the High-Cost Project Threshold, then those Reinforcement costs, for each CAF, shall be scaled down by the ratio of the High-Cost Project Threshold to the total Reinforcement costs at the Voltage Level of the POC in accordance with the following formula (see Examples 32 and 33):

$$\text{Reinforcement cost} \times \frac{\text{High-Cost Project Threshold}}{\text{Total Reinforcement cost at the Voltage Level of the POC}}$$

- 1.19 For Demand Connections, the costs of Reinforcement will be paid in full by us, unless other exceptions apply which take precedence.
- 1.20 If you choose not to pay (i) Reinforcement costs for the Minimum Scheme for a Non-Curtailable Connection or (ii) Reinforcement costs in excess of the High-Cost Project Threshold for a Non-Curtailable Connection, then you can request an enduring Curtailable Connection instead (i.e. one which will not convert to a Non-Curtailable Connection in the future). If you subsequently require a Non-Curtailable Connection, then this would require a new connection request which may still be subject to Reinforcement costs, potentially in excess of the High-Cost Project Threshold.
- 1.21 Where one of the exceptions set out in paragraphs 1.22 to 1.27 applies, Reinforcement will be treated as Extension Assets and the costs of the Reinforcement will not be apportioned or paid in full by us. The application of the exceptions is demonstrated in the Examples.
- 1.22 Exception 1: Where the Reinforcement is:
- downstream of the POC; and
 - over and above the Minimum Scheme; and
 - provided at our request; and
 - provided by connecting two points on the existing Distribution System,

then the apportionment rules will not apply. You will pay the costs associated with the Minimum Scheme and we will pay the costs over and above the Minimum Scheme. See Example 4.

1.23 Exception 2: Where the Reinforcement is in excess of the Minimum Scheme and is at your request, the Reinforcement will be treated as Extension Assets and the apportionment rules will not apply. The costs in excess of the Minimum Scheme will be borne in full by you (see paragraphs 1.11 and 1.12 above). See Example 3.

1.24 Exception 3: Where the Reinforcement is provided to accommodate a Temporary Connection the Reinforcement will be treated as Extension Assets and the apportionment rules will not apply. Consequently, in such circumstances, you will pay in full the costs associated with the Temporary Connection. Temporary Connections are defined as connections that are only required for a period of up to five years, but exclude connections to provide the initial connection to a development, where the Reinforcement will subsequently be required for the permanent connection.

1.25 Exception 4: Where the replacement of switchgear results in an increase in fault level capacity and:

- that increase is solely as a result of the fault level rating of the standard switchgear equipment used by us being higher than that of the existing switchgear; and
- that increase in fault level capacity is not needed to accommodate your connection.

then, unless the switchgear adds network capacity and the Security CAF applies, the switchgear replacement will be treated as Extension Assets and the apportionment rules will not apply. Consequently, in such circumstances, you will pay the full cost of the switchgear replacement. See Example 15.

1.26 Exception 5: Where the Minimum Scheme requires Reinforcement that is provided by connecting two points on the existing Distribution System to provide connectivity to your Premises, then the lowest cost feeder shall be treated as an Extension Asset and all other feeders required to connect your Premises shall be treated as Reinforcement. See Example 17.

1.27 Exception 6: Where the Reinforcement:

- is provided by connecting two points on the existing Distribution System; and
- is providing connection to a development with a number of Entry/ Exit Points,

then the additional network length (measured from suitable points close to the site boundaries which would allow for a clear demarcation of Contestable and Non-Contestable Work) required to provide connectivity within the development will be considered to be Extension Assets and the apportionment rules will not apply. Consequently, in such circumstances, you will pay the full cost of the additional network length. See Example 18.

Costs to be apportioned between you and us

1.28 The costs of Reinforcement will be apportioned using one of two Cost Apportionment Factors (CAFs), dependent upon which factor is driving the requirement for Reinforcement:

- The ‘Security CAF’; and
- The ‘Fault Level CAF’.

1.29 The following definitions are used in the application of the CAFs.

Existing Capacity	For existing Customers their Existing Capacity will be either: <ul style="list-style-type: none"> (a) the Maximum Capacity used in the calculation of their use of system charges; or (b) for Customers who are not charged for use of system on the basis of their Maximum Capacity the lower of: <ul style="list-style-type: none"> • No. of phases x nominal phase-neutral voltage (kV) x fuse rating (A); and • The rating of the service equipment.
Fault Level Contribution from Connection	is the assessment of the Fault Level contribution from the equipment to be connected taking account of its impact at the appropriate point on the Distribution System. Where an existing Customer requests a change to a connection then the “Fault Level Contribution from Connection” is

	defined as the incremental increase in Fault Level caused by the Customer.
New Fault Level Capacity	is the Fault Level rating, following Reinforcement, of the equipment installed after taking account of any restrictions imposed by the local network Fault Level capacity. For the avoidance of doubt this rule will be used for all equipment types and voltages.
New Network Capacity	<p>is either the secure or non-secure capacity of the Relevant Section of Network (RSN) following Reinforcement. Whether secure or non-secure capacity is applicable depends upon the type of capacity that can be provided from the RSN. For example, if the capacity provided to the Customer by the RSN is secure, but the capacity requested by the Customer at the point of connection is non-secure, the secure capacity will be used. See Example 24.</p> <p>The capacity to be used will be based on our assessment of the thermal ratings, voltage change and upstream restrictions and compliance with our relevant design, planning and security of supply policies. The equipment ratings to be used are the appropriate operational rating at the time of the most onerous operational conditions taking account of seasonal ratings and demand.</p>
Relevant Section of Network (RSN)	<p>is that part or parts of the Distribution System which require(s) Reinforcement. Normally this will comprise:</p> <ul style="list-style-type: none"> • the existing assets, at the Voltage Level that is being reinforced, that would have been used to supply you (so far as they have not been replaced) had sufficient capacity been available to connect you without Reinforcement; and/or • the new assets, at the same Voltage Level, that are to be provided by way of Reinforcement. <p>Where it is unclear what assets would have supplied the Customer in the event that sufficient capacity had been available, the existing individual assets with the closest rating to the new assets will be used.</p> <p>There may be more than one RSN (e.g. at different Voltage Levels).</p>

Required Capacity	is the Maximum Capacity agreed with the Customer. In the case of multiple connections (e.g. a housing development) it may be adjusted after consideration of the effects of diversity. Where an existing Customer requests an increase in capacity then it is the increase above their Existing Capacity.
--------------------------	---

1.30 The ‘Security CAF’ is applied, where the costs are driven by either thermal capacity or voltage (or both) as assessed against the relevant standard. This rule determines the proportion of the Reinforcement costs that should be paid by you as detailed below.

$$\text{Security CAF} = \frac{\text{Required Capacity}}{\text{New Network Capacity}} \times 100\% \quad (\text{max } 100\%)$$

1.31 The ‘Fault Level CAF’ is applied, where the costs are driven by Fault Level restrictions. This rule determines the proportion of the Reinforcement costs that should be paid by you as detailed below.

$$\text{Fault Level CAF} = 3 \times \frac{\text{Fault Level Contribution from Connection}}{\text{New Fault Level Capacity}} \times 100\% \quad (\text{max } 100\%)$$

1.32 For clarity, where you require an augmentation to an existing connection, both the Security and Fault Level CAFs will be based on the increase in Required Capacity and increase in Fault Level Contribution from the connection respectively. Any related increases within the previous three year period will be taken into account in determining the increase in the Required Capacity or increase in the Fault Level Contribution from the connection to be applied within the CAF.

1.33 On some Schemes there may be interaction between the two rules. In such cases, the ‘Security’ CAF will be applied to costs that are driven by the security requirement. The ‘Fault Level CAF’ will be applied to costs that are driven by Fault Level requirements. See the Examples for illustrations on the application of the CAFs.

Recovery of costs for previous works

1.34 Where, in order to provide your connection;

- we propose to utilise existing Distribution System assets that were previously installed to provide a connection to another customer, and
- the other customer has paid us (either in part or in full) a Connection Charge for those assets or paid an ICP for those assets which were adopted by us,

you may be required to make a payment towards them. The ECCR prescribes the circumstances where such payment is required. Charges for such works only apply where the new connection is provided within the ECCR Prescribed Period.

Costs to be paid in full by us

1.35 For Demand Connections we will fully fund all Reinforcement. For Generation Connections, we will fully fund Reinforcement carried out at a Voltage Level higher than the Voltage Level at the POC to the existing Distribution System. However, there are exceptions to these two approaches, as set out elsewhere in this methodology.

1.36 We will fully fund Reinforcement carried out to allow the installation of all equipment at an existing Premises which remain connected via an existing low-voltage single, two or three phase service fused at 100 amperes or less per phase which is metered with whole-current metering; provided that (to the extent relevant):

- the Reinforcement is carried out to allow the installation of equipment as part of a single application for a single or multiple installations;
- any and all electricity generation equipment installed has a rated output not greater than 16 amperes per phase (or not greater than 16 amperes per phase at any single Premises if a single application for multiple installations);
- any and all equipment installed which does not constitute a modification to the existing service conforms with the technical requirements of the following standards (notwithstanding that the equipment may have an input current that is more than 16 amperes per phase):
 - BS EN 61000-3-2 Electromagnetic compatibility (EMC). Limits. Limits for harmonic current emissions (equipment input current ≤ 16 A per phase); and

- BS EN 61000-3-3 Electromagnetic compatibility (EMC). Limits. Limitation of voltage changes, voltage fluctuations and flicker in public low-voltage supply systems, for equipment with rated current ≤ 16 A per phase and not subject to conditional connection.

1.37 Where it is necessary to modify a low-voltage single phase looped service for an existing Premises, this shall be considered to have remained connected under paragraph 1.36 above.

1.38 Where another LDNO with a distribution network that is connected to our Distribution System requires an increase in capacity to its distribution network, the voltage at the POC for assessing the Voltage Level will be:

- in the case of a new extension to the network of the other LDNO, the voltage of connection at which the Extension Assets will connect to the other LDNO's network; or
- in the case of additional capacity required in respect of a customer connected to the existing assets of the LDNO, the voltage at which the customer connects to the LDNO's network; or
- in the case of additional capacity required to meet general load growth on the LDNO's network then the Reinforcement costs will be borne by us. The LDNO will be required to provide justification in such circumstances.

1.39 The tables below illustrate the application of the voltage rules in relation to Reinforcement for Demand Connections and Generation Connections. For Generation Connections, you will be required to contribute towards the cost of any Reinforcement provided at the Voltage Level of the POC, up to and including the cost of circuit breakers provided at that voltage.

England and Wales

Demand Connections				
	Voltage at the POC			
Voltage of Scheme Assets	LV (at or below 1000V)	HV (above 1kV but not more than 22kV)	EHV (above 22kV but not more than 72kV)	132kV
132kV Network	We fund	We fund	We fund	We fund
132kV/ EHV Substation	We fund	We fund	We fund	Not applicable
EHV Network	We fund	We fund	We fund	Not applicable
132kV/ HV Substation	We fund	We fund	Not applicable	Not applicable
EHV/HV Substation	We fund	We fund	Not applicable	Not applicable
EHV/LV substation	We fund	Not applicable	Not applicable	Not applicable
HV Network	We fund	We fund	Not applicable	Not applicable
HV/ LV Substation	We fund	Not applicable	Not applicable	Not applicable
LV Network	We fund	Not applicable	Not applicable	Not applicable

NB: The above table may not accommodate every possible circumstance, where this is the case, the Voltage Level (as defined in the Glossary) shall be applied.

Generation Connections				
	Voltage at the POC			
Voltage of Scheme Assets	LV (at or below 1000V)	HV (above 1kV but not more than 22kV)	EHV (above 22kV but not more than 72kV)	132kV
132kV Network	We fund	We fund	We fund	AppORTIONED
132kV/ EHV Substation	We fund	We fund	EHV circuit breakers only AppORTIONED	Not applicable
EHV Network	We fund	We fund	AppORTIONED	Not applicable
132kV/ HV Substation	We fund	HV circuit breakers only AppORTIONED	Not applicable	Not applicable
EHV/HV Substation	We fund	HV circuit breakers only AppORTIONED	Not applicable	Not applicable
EHV/LV Substation	LV board only AppORTIONED	Not applicable	Not applicable	Not applicable
HV Network	We fund	AppORTIONED	Not applicable	Not applicable
HV/ LV Substation	LV board only AppORTIONED	Not applicable	Not applicable	Not applicable
LV Network	AppORTIONED	Not applicable	Not applicable	Not applicable

NB: The above table may not accommodate every possible circumstance, where this is the case, the Voltage Level (as defined in the Glossary) shall be applied.

Scotland

Demand Connections			
	Voltage at the POC		
Voltage of Scheme Assets	LV (at or below 1000V)	HV (above 1kV but not more than 22kV)	EHV (above 22kV but not more than 72kV)
EHV Network	We fund	We fund	We fund
EHV/HV Substation	We fund	We fund	Not applicable
EHV/LV substation	We fund	Not applicable	Not applicable
HV Network	We fund	We fund	Not applicable
HV/ LV Substation	We fund	Not applicable	Not applicable
LV Network	We fund	Not applicable	Not applicable

NB: The above table may not accommodate every possible circumstance, where this is the case, the Voltage Level (as defined in the Glossary) shall be applied.

Generation Connections			
	Voltage at the POC		
Voltage of Scheme Assets	LV (at or below 1000V)	HV (above 1kV but not more than 22kV)	EHV (above 22kV but not more than 72kV)
EHV Network	We fund	We fund	Apportioned
EHV/HV Substation	We fund	HV circuit breakers only Apportioned	Not applicable
EHV/LV Substation	LV board only Apportioned	Not applicable	Not applicable
HV Network	We fund	Apportioned	Not applicable
HV/ LV Substation	LV board only Apportioned	Not applicable	Not applicable
LV Network	Apportioned	Not applicable	Not applicable

NB: The above table may not accommodate every possible circumstance, where this is the case, the Voltage Level (as defined in the Glossary) shall be applied.

Additional Cost Allocation for Flexible Connections and Curtailable Connections

1.40 To facilitate the provision of a Flexible Connection or a Curtailable Connection, we may need to install and maintain specific system management equipment, at your Premises and/or further upstream in other parts of the Distribution System. Some of the costs associated with installing, operating and maintaining the system management equipment will be directly attributed to your connection and be included as part of your Connection Charge (see illustrative table in paragraph 1.41). The proportion of the costs which you must fund depends on whether your connection forms part of a Dedicated Scheme or a Wide Area Scheme, as described below:

Type 1 – Dedicated Scheme: A scheme managing constraint(s) where there are no customers downstream of the constraint(s) who could connect new or additional demand or generation without being controlled by the Dedicated Scheme:

- Type ‘1A’ considers a scenario involving only one customer; and
- Type ‘1B’ considers a scenario involving multiple customers.

Type 2 – Wide Area Scheme: A scheme managing constraint(s) where there are customers downstream of the constraint(s) who could connect new or additional demand or generation without being controlled by the Wide Area Scheme.

1.41 The table below illustrates the scheme types and methodology for cost recovery associated with each type of Flexible Connection or a Curtailable Connection. The methodology covers Type 1A, Type 1B and Type 2 (as each is described in paragraph 1.40).

Typical connection components¹	Type 1A - Single	Type 1B - Multiple	Type 2 - Wide Area
Extension Assets for customer	You fund	You fund	You fund
End user control unit for the customer	You fund	You fund	You fund
Local system management unit	You fund	Shared equally between participants	We fund
Scheme management unit	You fund	Shared equally between participants	We fund
Central management unit	N/A	N/A	We fund
Scheme specific ongoing costs e.g. communications	We fund	We fund	We fund

¹We will describe the main connection components within the relevant connection offer, which will also include the funding arrangements for each such connection component (if different to that stated in this illustrative table).

Recovered Equipment and Deferral of Asset Replacement

1.42 Normally, you will not receive any credit for the value of any equipment recovered by us as a result of providing the connection. However, where a Temporary Connection is to be Disconnected, we will determine the value of recovered equipment that we can subsequently reuse (net of depreciation and removal and refurbishment costs). Where there is a net value in the recovered equipment that can be reused, we will pay you the amount of such net value subject to a de minimis level as specified in Section [6].

1.43 You will not receive any credit for the value of any deferral of asset renewal expenditure by us.

Rebates

1.44 For Distribution System assets where you have paid in full, then you may be entitled to a reimbursement payment under the ECCR should another Customer connect to those assets. These circumstances are detailed in the ECCR.

- 1.45 For Distribution System assets where you have paid in proportion to your Required Capacity, then you are not entitled to a future rebate of charges should another Customer connect to those assets.
- 1.46 Your entitlement to receive payments under the ECCR only applies to connections made within the ECCR Prescribed Period from the first provision of the connection.
- 1.47 These provisions do not apply where your connection was made before 6 April 2017 and we have adopted the assets from an ICP. However, for connections made on or after 6 April 2017, these provisions do apply to assets we have adopted from an ICP (as further described in the ECCR).

Speculative Developments

- 1.48 Developments which have one or more of the following characteristics may be considered as speculative:
- their detailed electrical load requirements are not known;
 - the development is phased over a period of time and the timing of the phases is unclear;
 - the capacity requested caters for future expansion rather than the immediate requirements of (an) end user(s);
 - the capacity requested caters for future speculative phases of a development rather than the initial phase(s) of the development; or
 - the infrastructure only is being provided, with no connections for end users requested.
- 1.49 Where we are asked to provide a connection to a speculative development then the cost of the work including any Reinforcement is charged in full and the CAFs do not apply. Additional charges to reflect ongoing operation, repair and maintenance costs may also be levied.
- 1.50 We may, at our sole discretion, allow capacity to be reserved on the infrastructure provided to service the speculative development on the commercial terms agreed between you and us in respect of the development.

1.51 Applications will be assessed to determine whether they are a Speculative Development by using the Speculative Developments scoring system described in paragraphs 1.52-1.70, which will be applied as follows:

- Consideration will be given to the fact that some aspects of an application may have a greater bearing on whether the application should be considered as not being a Speculative Development. In recognition of this, the criteria used in the scoring system are weighted as either high or low significance.
- Only the points identified in the scoring criteria shall be placed against each respective criterion that is relevant to the application. Each high significance criterion shall be scored 2 points and each low significance criterion shall be scored 1 point, without exception.
- The number of points entered in the ‘speculative’ and ‘non-speculative’ columns shall be added up to give a total number for the respective column, as shown in the scoring proforma below.
- If the total value of points for the ‘speculative’ column is greater than the total value of points for the ‘non-speculative’ column, then the application will be considered as being a Speculative Development.
- If there is no score in either column, then we reserve the right to obtain additional information prior to making the assessment.
- All criteria may not apply to every application.

Scoring Proforma		
Criteria	Non-Speculative Points	Speculative Points
1		
2		
3		
4		Not applicable

5		
6		Not applicable
Total points		

Criterion 1: Programme (domestic and non-domestic developments)

1.52 This criterion is deemed to be of low significance.

1.53 The application will receive points in the ‘non-speculative’ column, if:

- the development has an overall timescale of up to two years from the date of the initial application is made until the completion of the final phase; or
- the applicant has provided a clear phasing plan for the complete development.

1.54 The application will receive points in the ‘speculative’ column, if:

- the development has an overall timescale of more than ten years from the date on which the initial application is made to completion of the final phase; and
- the applicant does not provide a clear phasing plan for the complete development.

1.55 Should the Customer’s development be phased over a period greater than two years but less than or equal to ten years, then no points shall be entered in either the ‘speculative’ or ‘non-speculative’ columns.

Criterion 2: Programme (domestic developments only)

1.56 This criterion is deemed to be of high significance.

1.57 The application will receive points in the ‘non-speculative’ column if the complete development comprises less than 100 dwellings or requires less than three permanent HV/LV substations beyond the POC.

1.58 The application will receive points in the ‘speculative’ column, if the complete development includes more than 5,000 dwellings or requires more than ten permanent HV/LV substations beyond the POC.

1.59 Should the characteristics of the customers development fall between these two thresholds, then no points shall be entered in either of the ‘speculative’ or ‘non-speculative’ columns.

Criterion 3: Load Profile

1.60 This criterion is deemed to be of high significance.

1.61 The application will receive points in the ‘non-speculative’ column if the application is for a development that is (or will become) a Phased Capacity Site.

1.62 The application will receive points in the ‘speculative’ column if the applicant does not provide an acceptable (to us) capacity ramp profile and a portion of the Required Capacity is for future expansion.

Criterion 4: Financial Commitment

1.63 This criterion is deemed to be of low significance.

1.64 The application will receive points in the ‘non-speculative’ column if the applicant makes a financial commitment in support of the application. A financial commitment is made where the applicant agrees to pay for:

- assets installed at initial connection which are sized sufficiently to accommodate the complete future development and which are greater than the assets to accommodate the capacity to be utilised in the early phases of construction; and
- any operation and maintenance costs for such increased assets which may be included within the connection offer prior to the initial energisation of the connection.

Criterion 5: Future Provision

1.65 This criterion is deemed to be of high significance.

1.66 The application will receive points in the ‘non-speculative’ column if at least 75% of the total connections and/or at least 75% of the total load are delivered in the first phase of the development (excluding any temporary works).

- 1.67 The application will receive points in the ‘speculative’ column if only infrastructure is being provided, with no connections for end users requested, and the development is not within the relevant local authority’s development plans.

Criterion 6: Planning Permission

- 1.68 The application will receive points in the ‘non-speculative’ column reflective of a high significance criterion if the complete development has achieved Full Planning Permission.
- 1.69 The application will receive points in the ‘non-speculative’ column reflective of a low significance criterion if the complete development has only achieved Outline Planning Permission.
- 1.70 For clarity, the absence of any planning permission/consent for the development will not result in any points being added to the ‘speculative’ column.

Connection Alterations

- 1.71 Where you request an alteration to your connection arrangements, including a change in the supply voltage, the costs are charged in full to you. For the avoidance of doubt increases in the Required Capacity are dealt with in accordance with the previous Sections.

Independent System Operator and Planner (ISOP) Charges

- 1.72 We have an obligation under the CUSC to discuss certain requests for connection or changes in connection with the ISOP. Such requests are typically for large electrical demand or generation projects. Under certain circumstances, as determined by the ISOP, they may apply charges to assess the potential impact on the GB Transmission System of a request or the combined effect of a number of requests and these will be included in the Connection Charge, or through a separate mechanism agreed between you and us.
- 1.73 Subsequent to such assessment, the ISOP may also require works to be undertaken on the GB Transmission System as a condition of the connection being permitted. In the event of ISOP applying charges for these works, we will reflect these charges in our charges to you.

- 1.74 Should GB Transmission System works be required, ISOP may apply a cancellation charge in the event that your project is cancelled or the capacity of your project reduces. The ISOP also calculates a secured amount in respect of this cancellation charge (being a percentage of the cancellation charge, which reduces at certain trigger points). We may ask you for security in respect of this cancellation charge, but we will not ask you for more than the secured amount calculated by the ISOP.

Land Rights

- 1.75 Where Land Rights are required from a third party, the cost of acquiring those rights will be included in either the Connection Charge to you or through a separate mechanism agreed between you and us.
- 1.76 If the Land Rights that we require cannot be obtained by negotiation, we may, following discussion with you, exercise our powers of compulsory purchase (Section 10 and Schedule 3 of the Act) or apply to the Secretary of State or the Scottish Government in Scotland for a ‘necessary wayleave’ (paragraphs 6-8 of Schedule 4 of the Act). If we do so, the costs that we incur, including those of the Lands Tribunal/ Lands Tribunal for Scotland (which determine issues of compensation) will be charged to you. The Lands Tribunal may award compensation to the landowner and/or anyone who holds an interest in the land and this will be included in the Connection Charge or through a separate mechanism agreed between you and us.

Unmetered Supplies

- 1.77 For some street lighting and other installations, we may allow items of equipment to be connected to our Distribution System without a meter. This is subject to the equipment having a low and predictable pattern of consumption and meeting the requirements of The Electricity (Unmetered Supply) Regulations 2001.
- 1.78 Where we agree that a meter is not required the provision of such a connection is dependent on the owner entering into an unmetered Connection Agreement and providing and maintaining an auditable inventory, in a format agreed with us, so that an accurate estimate of the consumption can be produced.

- 1.79 Where certain criteria are met the provision of services for unmetered connections may be made via a time-based connection service charge, e.g. Rent-a-Jointer Services. This is subject to us entering into a contract with you for the provision of such services.
- 1.80 You may elect to appoint an accredited ICP to carry out the Contestable Work for unmetered connections. The ICP will be allowed to carry out live jointing on low voltage, underground cables. Where you use an ICP, arrangements must first be established as follows:
- You will enter into an agreement with the ICP to carry out and complete the Contestable Work; and
 - We will enter into an agreement and/or an Adoption Agreement with you and/or your appointed ICP as appropriate.

Capacity Ramping for LDNOs

- 1.81 For an LDNO the Required Capacity (expressed in kVA) is the Maximum Capacity to be provided at the boundary between the LDNO's distribution network and our Distribution System. This value will be agreed with us and stated in the Bilateral Connection Agreement for the relevant embedded network.
- 1.82 When a connection is provided to an LDNO the take-up of capacity may grow over a period of time as the site develops and individual customers are connected. In such circumstances the Bilateral Connection Agreement shall include a phased Required Capacity based on the Development Phase.
- 1.83 During the Development Phase a review may be undertaken annually on the anniversary of the Energisation of the embedded network. Any unused capacity identified in such review may be released for use by other customers and the Maximum Capacity reduced to an agreed level within the Bilateral Connection Agreement.
- 1.84 The Required Capacity agreed with us as being required at the end of the Development Phase shall be used to determine the Required Capacity for determination of the Cost Apportionment Factors where applicable.
- 1.85 Should additional capacity subsequently be required, the LDNO may incur additional Connection Charges for any Reinforcement based on the increase in capacity.

Phased Capacity Site

- 1.86 If a Customer has a requirement for capacity to increase over a period of time, then a phased Required Capacity can be agreed. The phased Required Capacity will be documented in the Connection Agreement for the connection.
- 1.87 The DNO will use the phased Required Capacity to assess the needs of the Distribution System and what, if any, Reinforcement is required. Any Reinforcement will be charged in accordance with the Charging Methodology for a Demand Connection or Generation Connection, as appropriate.
- 1.88 The DNO will use the phased Required Capacity, updated in the Connection Agreement and as applicable at the relevant time, as the Maximum Capacity for the purposes of calculating the Customer's Use of System Charges.
- 1.89 By agreeing a phased Required Capacity, the Customer is committing to pay, from Energisation of the connection, Use of System Charges based upon the residual charging band allocated in accordance with DCUSA Schedule 32 (Residual Charging Bands) based on the Required Capacity for the complete development. For example, if the connection will be ramped from 1MVA to 5MVA over 10 years, the Customer is committing to pay Use of System Charges for a 5MVA connection in line with the ramped profile (i.e. when the capacity is ramped to 5MVA in year 10).
- 1.90 During the Development Phase a review may be undertaken annually on or around the anniversary of the date of Energisation of the connection. The results of that review will be discussed, and we may require reasonable changes to the phasing as a result of that review.

Disconnection and De-Energisation

- 1.91 If we either Disconnect or De-energise your Entry/ Exit Point:
- at the request of your Supplier; or
 - due to a failure of your Supplier to comply with the terms of the DCUSA,
- then the cost of such disconnection or De-energisation will be borne by your Supplier.
- 1.92 If we either Disconnect or De-energise your Entry/ Exit Point:

- at your request; or
 - due to a failure by you to comply with the terms of your Connection Agreement,
- then the cost of such disconnection or De-energisation will be borne by you.

1.93 On termination of your Connection Agreement, we retain the right to remove our Electrical Plant and Electric Lines and charge you if we do so. Apparatus which is not cost effective for us to recover (e.g. Electric Lines laid underground) will normally be made safe and left at the Premises, but if you require us to remove them, the cost of removal will be payable by you. All such apparatus will remain our property unless otherwise agreed in writing.

Adoption Payments

1.94 Where we adopt assets installed by an ICP we will not make any adoption payment in respect of those assets.

Competition in Connections

1.95 Where you choose to have any Contestable Work undertaken by an ICP, we levy CIC Charges associated with the design approval, inspection and adoption of the Contestable Works as set out in Section [6] and Section [7].

Worked Examples Illustrating the Application of the Connection Charging Methodology

The following Examples are to illustrate the application of the Connection Charging Methodology and are not intended to provide an accurate estimate of the charges for which a person would become liable in respect of the provision of a connection. The Examples do not necessarily represent the Minimum Scheme for a specific connection application or how we would classify a connection between what is a Demand Connection or Generation Connection. Where an example only applies to either Demand or Generation Connections, then this is identified in the Example title, otherwise the examples apply to both.

The figures quoted in the Examples are illustrative. Section [7] of this statement provides our charges and indicative costs to undertake various activities.

The Examples illustrate where we undertake both the Contestable and Non-Contestable Work. These costs will include the determination of the POC and assessment and design costs, though these are not explicitly identified in the Examples.

Where Contestable Work is undertaken by an ICP, we will apply CIC Charges for services associated with the Contestable Works which would cover activities including design approval, inspection and monitoring. The CIC Charges are not shown in the Examples. For the avoidance of doubt, in each Example, where an ICP undertakes the Contestable Work, our Connection Charge will include the cost of the Non-Contestable Work and the CIC Charges but exclude the cost of Contestable Work.

The Examples are generic and standard for all LDNOs, but they do not represent the network analysis and subsequent design solutions that would be completed for an actual connection scheme. The actual designs are subject to our design policies.

For illustrative purposes only, the rated capacities of the Examples use 'kVA, MVA' and 'kW, MW' interchangeably.











Index of Examples

Example	Description	Purpose
1	A new connection at LV	To show Extension Assets are charged in full to the Customer.
2	A new connection at HV	To show LV and HV Extension Assets are charged in full to the Customer.
3	A new connection on a domestic housing development with interconnection requested by Customer	To illustrate Exception 2 where the interconnection is treated as Extension Assets and are charged in full to the Customer.
4	A new connection with interconnection requested by us.	To illustrate Exception 1 where LV and HV Extension Assets are charged in full to the Customer, but the interconnection is paid in full by us.
5	A new connection where the Minimum Scheme is a new substation teed onto the existing HV network.	Simple example of a commercial connection, Extension Assets only, so charged in full to the Customer.
6	A new connection where the Minimum Scheme is a new substation looped into existing HV network.	Simple example of looped connection, Extension Assets only, so charged in full to the Customer.
7	A new connection where the Minimum Scheme is as for Example 5 but the Customer requests an enhanced connection arrangement where the substation is looped into existing HV network.	Shows that for a Customer requested Enhanced Scheme that the Customer pays costs above the Minimum Scheme plus O&M.
8	A new connection where the Minimum Scheme is as for Example 5 but we request an Enhanced Scheme where the substation is looped into the existing HV network.	Shows that for a DNO requested Enhanced Scheme that the DNO pays for all costs above Minimum Scheme.
9	An additional load application requiring a new connection from the HV network and Reinforcement.	To demonstrate the treatment of Reinforcement cost for a Demand Connection that drives Reinforcement.
10	A new connection that results in a Point of Connection further away than the nearest network.	To show that the Minimum Scheme may result in a Point of Connection that is further away than the nearest network and may result in increased Extension Asset costs that are charged in full to the Customer.
11	A new Generation Connection with capacity triggered Reinforcement.	To demonstrate the treatment of Reinforcement cost for a Generation Connection which drives Reinforcement using the Security CAF.

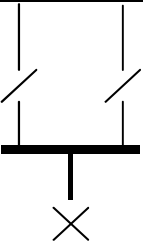
Example	Description	Purpose
12	A new Generation Connection with Fault Level Triggered Reinforcement.	To demonstrate how the Fault Level CAF calculation is applied.
13	A new Generation Connection that requires Reinforcement involving both Security and Fault Level CAFs.	To demonstrate Reinforcement charging principles for a Generation Connection where both Security CAF and Fault Level CAF are applicable.
14	A new Generation Connection with Reinforcement at a voltage above that of the Point of Connection.	To illustrate that a Generation Connection does not contribute to Reinforcement costs at a voltage level above the connection voltage.
15	New Generation Connection where switchgear extension is not possible and switchgear replacement is needed	Illustrate Exception 4, if switchgear extension not possible, then treated as Extension Assets and costs are charged in full to the Customer.
16	A new Storage Connection that triggers Reinforcement	To show that Storage, when not co-located with other demand, is treated as a Generation Connection for the purposes of charging and any Reinforcement at the same Voltage of the POC will be charged, irrespective of whether the Reinforcement is due to the import or the export.
17	A new connection that is connected by Reinforced assets	To demonstrate the application of Exception 5 where the Customer needs to pay for the assets that connect them to the existing network.
18	A new connection of a development	To demonstrate the application of Exception 6 where the Customer pays for assets within the site boundary.
19	A new connection with remote network Reinforcement	To show treatment where capacity is created on a different part of the network and a load transfer is required to allow the connection. Example again demonstrates which elements are Reinforcement and which are Extension Assets.
20	A new connection with load transfer	Variation to Example 19 where a load transfer is required to free up capacity, but no new capacity is created and demonstrates why elements become Extension Assets.
21	A new Generation Connection with an Enhanced Scheme at the DNO's request.	To show how the Security CAF calculation is applied where the DNO requests an Enhanced Scheme.
22	A new Generation Connection on a meshed HV distribution system requiring Reinforcement.	To show that a contribution is required where Reinforcement is carried out at the same voltage as the Point of Connection for a Generation Connection.

Example	Description	Purpose
23	A non-secure Generation Connection with non-secure Reinforcement.	To show that a contribution is required where Reinforcement is carried out at the same voltage as the Point of Connection for a Generation Connection in relation to a non-secure system.
24	A new non-secure Generation Connection with secure Reinforcement.	To show the application of the apportionment rule where secure Reinforcement is provided but the connection for a Generation Connection is non-secure.
25	A new Generation Connection with voltage rise triggered Reinforcement.	To show that a Generation Connection pays for Reinforcement at the voltage level of connection based on the CAF.
26	A new Generation Connection with voltage rise triggered Reinforcement.	To show that if voltage rise Reinforcement is tailored so that just the amount of network is upgraded to meet the Customer requirements, the CAF is 100% for a Generation Connection.
27	A new Generation Connection with Fault Level Triggered Reinforcement and transmission works.	To show how the Fault Level CAF calculation is applied and how the cost of transmission works are treated for a Generation Connection.
28	A new Generation Connection with Fault Level triggered Reinforcement and transmission works.	To show the treatment of Reinforcement costs at more than one voltage level above the POC and the cost of transmission works for a Generation Connection.
29	A new Demand Connection that has Reinforcement above the High-Cost Project Threshold.	To show how the Demand High-Cost Project Threshold is applied.
30	A new Generation Connection that has Reinforcement above the High-Cost Project Threshold.	To show how a Generation Connection that triggers the Generation High-Cost Project Threshold is charged when the Reinforcement required is at the same voltage of connection.
31	The Customer requirements for supply characteristics are greater than the Minimum Scheme.	To illustrate that the Customer specifically requesting a three-phase connection, where the existing network is not of a sufficient number of phases, pays for any Reinforcement.
32	A new Generation Connection that has Reinforcement costs above the High-Cost Project Threshold at the Voltage Level of the POC (single asset to be cost apportioned).	To show how a Generation Connection that triggers the Generation High-Cost Project Threshold at the Voltage Level of the POC is charged when the Reinforcement required is for a single asset at the same Voltage Level of connection.
33	A new Generation Connection that has Reinforcement costs above the High-Cost Project Threshold at the Voltage Level of the POC (multiple assets to be cost apportioned).	To show how a Generation Connection that triggers the Generation High-Cost Project Threshold at the Voltage Level of the POC is charged when the Reinforcement required is for multiple assets at the same Voltage Level of connection.

Key to Illustrations

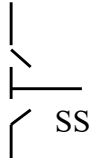
	Circuit Breaker (any voltage)
	Switch
	Transformer
	Joint on cable
	High voltage ring main unit
	Existing cable
	Proposed cable
	Normal Open Point (NOP)
	Generation Connection
	Demand Connection
	Point of Connection (POC)
	Sub Station

Example 1: A new connection at LV

Purpose: To show Extension Assets are charged in full to the Customer.

A Customer requests a LV single phase connection to a new house. The Premises can be connected to an existing LV main cable in the street.

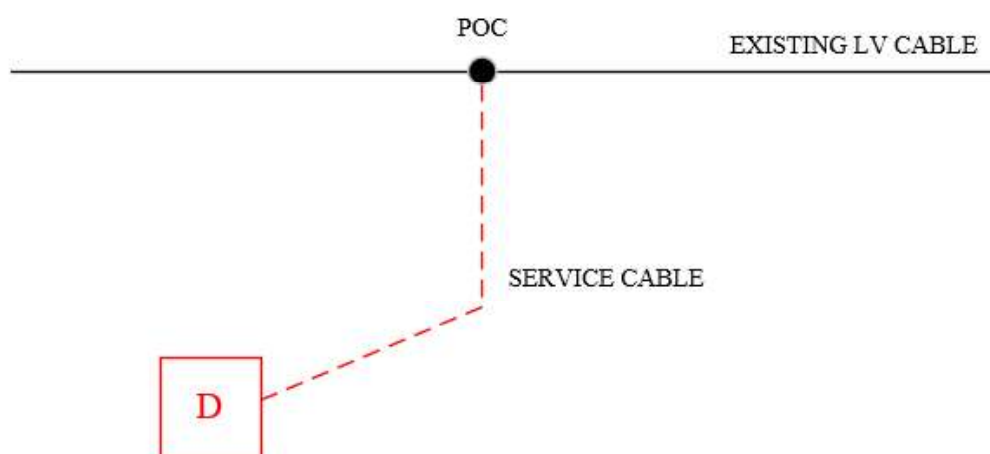

The Connection Charge for this Scheme is calculated as follows:

Extension Assets:

	Cost	Apportionment	Customer Contribution
15m service cable, excavation in footpath for joint hole to Customer laid duct, backfill and termination	£1,600	n/a	£1,600
Single service breach joint	£300	n/a	£300
Total Extension Asset Cost	£1,900		£1,900

Total cost of the work = £1,900

Total Connection Charge to Customer = £1,900

Example 2: A new connection at HV

Purpose: To show LV and HV Extension Assets are charged in full to the Customer.

A housing developer requests connection for 200 domestic Premises. The Required Capacity to supply the 200 homes is 250kVA. A new distribution substation will be established to provide the Required Capacity of the site. The Minimum Scheme requires the substation to be looped into the existing 11kV network.

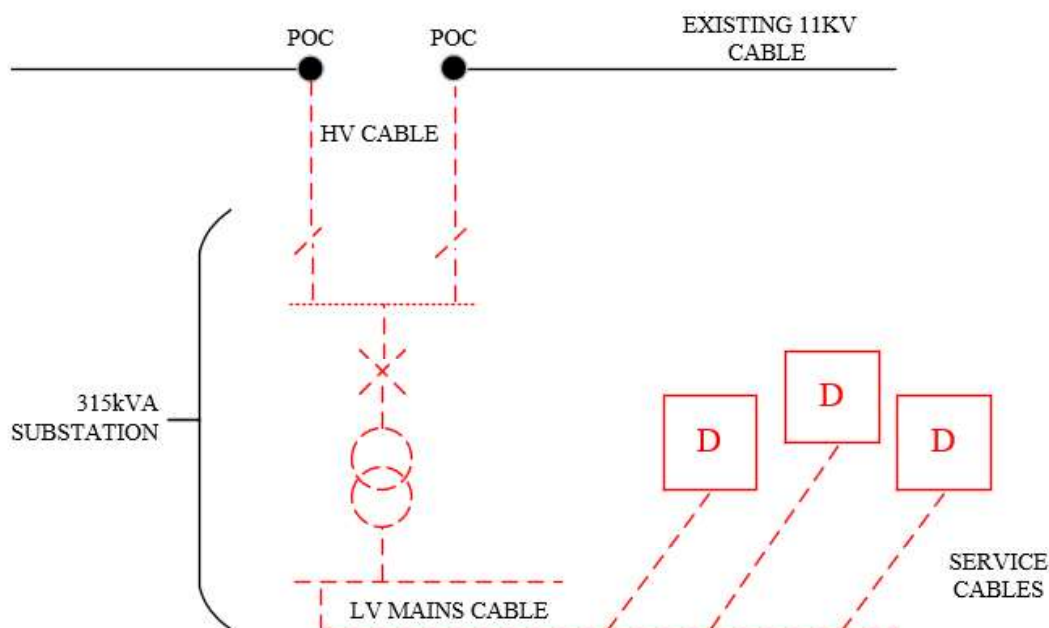

The Connection Charge for this Scheme is calculated as follows:

Extension Assets:	Cost	Apportionment	Customer Contribution
Provision and installation 100m 11kV cable	£30,000	n/a	£30,000
315kVA substation	£60,000	n/a	£60,000
LV mains, service cables and terminations	£200,000	n/a	£200,000
Two 11kV cable joints	£6,000	n/a	£6,000
Total Extension Asset Cost	£296,000		£296,000

Total cost of the work = £296,000

Total Connection Charge to Customer = £296,000

Example 3: A new connection on a domestic housing development with interconnection requested by Customer

Purpose: To illustrate Exception 2 where the interconnection is treated as Extension Assets and are charged in full to the Customer.

As in Example 2, a housing developer requests connections for 200 domestic Premises. The Required Capacity to supply the 200 homes is 250kVA. A new distribution substation will be established to provide the Required Capacity of the site. The Minimum Scheme requires the substation to be looped into the existing 11kV network. However, in this example there is an option to provide an additional LV cable to interconnect the distribution substation with the existing LV network. This option is over and above the Minimum Scheme.

Interconnecting into the existing LV network will increase the capacity of the existing Distribution System. Therefore, the assets that connect the 11kV and LV network would normally be considered to be Reinforcement. These assets (as shown on the diagram below) include the 11kV cable, the 315kVA substation and the interconnecting LV main. They exclude the LV mains and service cables from the 315kVA substation to the Customer's development. However, whether these assets are to be considered Reinforcement or Extension Assets depends upon who requested the LV interconnection.

In this case Exception 2 (Paragraph 1.23) applies as the LV interconnector is over and above the minimum scheme and requested by the Customer, therefore all assets (including the interconnecting LV cable) will be treated as Extension Assets and their costs will be borne in full by the Customer. As the interconnecting LV main and associated LV joint are over and above the Minimum Scheme, a charge for their future operation and maintenance will be made.

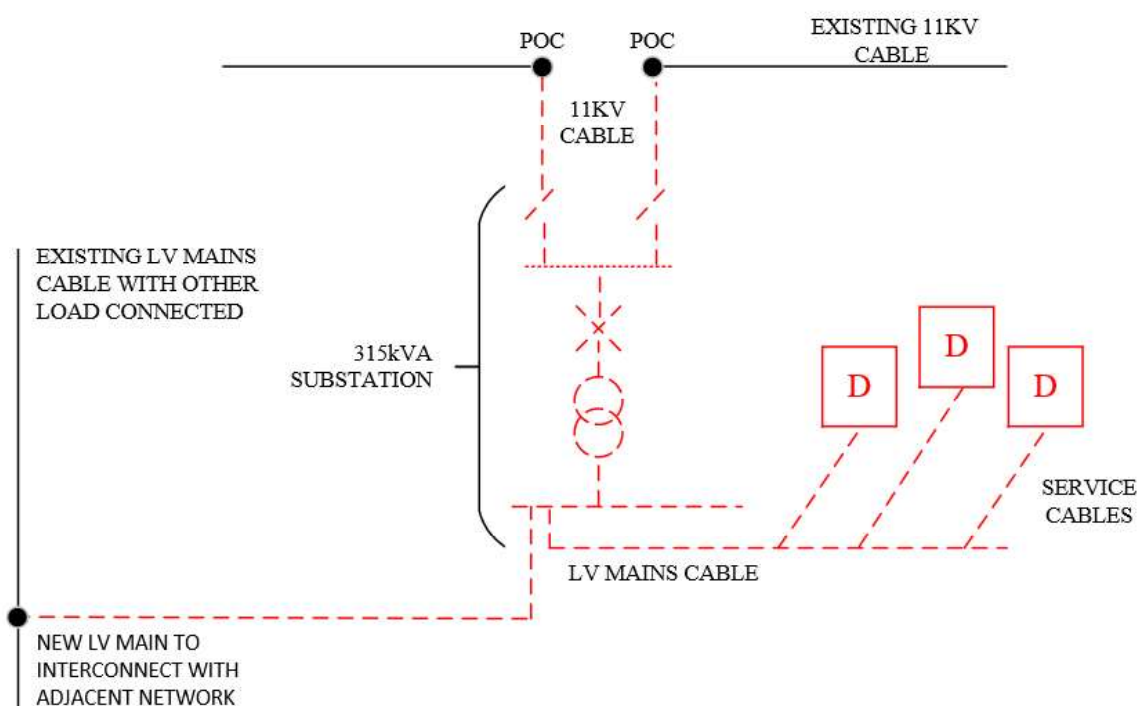

The Connection Charge for this Scheme is calculated as follows:

Extension Assets:	Cost	Apportionment	Customer Contribution
Provision and installation 100m 11kV cable (from existing 11kV network to substation)	£30,000	n/a	£30,000
315kVA substation	£60,000	n/a	£60,000
LV mains, service cables and terminations (from substation to the Customer's development)	£200,000	n/a	£200,000
Two 11kV cable joints	£6,000	n/a	£6,000
Interconnecting cable (from substation to existing LV network)	£12,000	In excess of Minimum Scheme	£12,000
LV cable joint	£300	In excess of Minimum Scheme	£300
Difference between Minimum Scheme and actual Scheme is £12,300. Operations & maintenance @ 20%* of £12,300		20%* of £12,300	£2,460
Total Extension Asset Cost	£308,300		£310,760

*Note, the 20% Operation and Maintenance percentage has been used for illustrative purposes only.

Total cost of the work = £308,300

Total Connection Charge to Customer = £308,300 + £2,460 = £310,760

Example 4: A new connection with interconnection requested by us

Purpose: To illustrate Exception 1 where LV and HV Extension Assets are charged in full to the Customer, but the interconnection is paid in full by us.

As in Example 2, a housing developer requests connections for 200 domestic Premises. The Required Capacity to supply the 200 homes is 250kVA. A new distribution substation will be established to provide the Required Capacity of the site. The Minimum Scheme requires the substation to be looped into the existing 11kV network. However, in this Example there is an option to provide an additional LV cable to interconnect the distribution substation with the existing LV network. This option is over and above the Minimum Scheme.

Interconnecting into the existing LV network will increase the capacity of the existing Distribution System. Therefore, the assets that connect the 11kV and LV network would normally be considered to be Reinforcement. These assets (as shown on the diagram below) include the 11kV cable, the 315kVA substation and the interconnecting LV main. They exclude the LV mains and service cables from the 315kVA substation to the Customer's development. However, whether these assets are to be considered Reinforcement or Extension Assets depends upon who requested the LV interconnection.

In this case all the requirements of Exception 1 (paragraph 1.22) are met so the assets that connect the existing 11kV and LV Distribution System will be treated as Extension Assets. The Customer will pay the costs associated with the Minimum Scheme in full. The interconnecting LV cable and associated LV joint, as they are over and above the Minimum Scheme and were requested by us, therefore the costs will be borne in full by us.

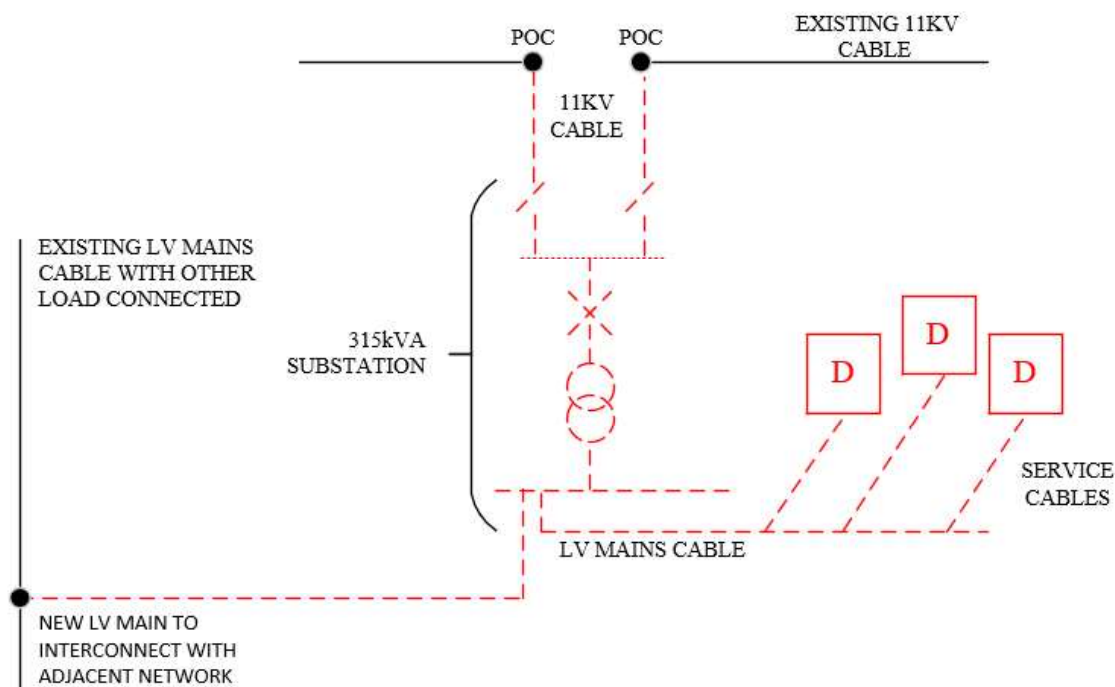

The Connection Charge for this Scheme is calculated as follows:

Extension Assets:	Cost	Apportionment	Customer Contribution
Provision and installation 100m 11kV cable (from existing 11kV network to substation)	£30,000	n/a	£30,000
315kVA substation	£60,000	n/a	£60,000
LV mains, service cables and terminations (from substation to the Customer's development)	£200,000	n/a	£200,000
Two 11kV cable joints	£6,000	n/a	£6,000
Interconnecting cable (from substation to existing LV network)	£12,000	In excess of Minimum Scheme	£0
LV cable joint	£300	In excess of Minimum Scheme	£0
Total Extension Asset Cost	£308,300		£296,000

Total cost of the work = £308,300

Total Connection Charge to Customer = £296,000

Example 5: A new connection where the Minimum Scheme is a new substation teed onto the existing HV network.

Purpose: Simple example of a commercial connection, Extension Assets only, so charged in full to the Customer.

A Customer requests a new LV three phase 600kVA connection to commercial Premises. Four scenarios for connection are considered in Examples 5 to 8. The Minimum Scheme will be dependent on the specific circumstances as set out in paragraphs 1.1 to 1.7.

In this example the Minimum Scheme is a new 800kVA substation teed onto the existing 11kV network. The figure below shows the proposed network.

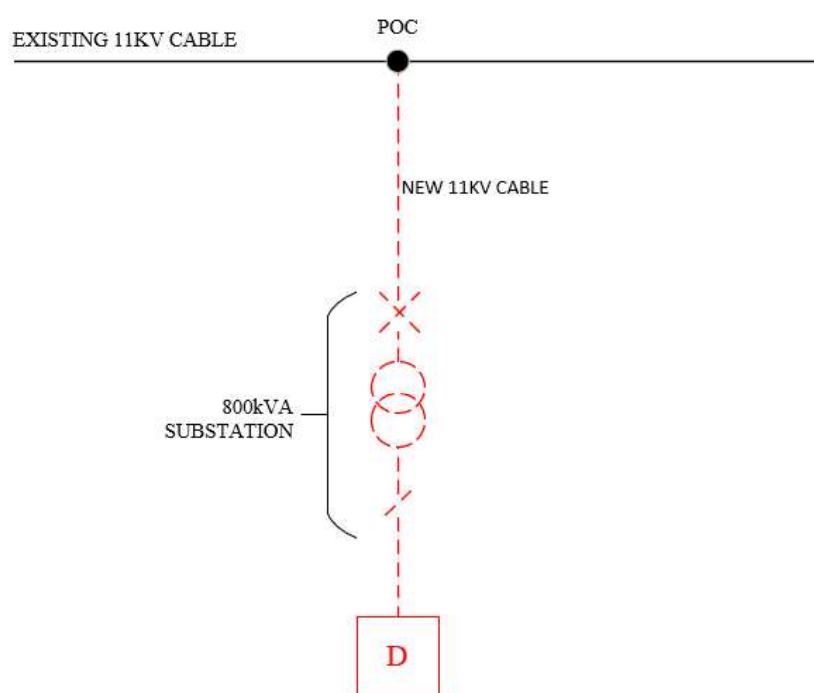

The Connection Charge for this Scheme is calculated as follows:

Extension Assets:	Cost	Apportionment	Customer Contribution
Provision and installation of 150m of 11kV cable	£45,000	n/a	£45,000
800kVA substation	£85,000	n/a	£85,000
Provision and installation LV cabling	£6,000	n/a	£6,000
LV Metering Panel	£4,000	n/a	£4,000
11kV joint to network	£3,000	n/a	£3,000
Total Extension Asset Cost	£143,000		£143,000

Total cost of the work = £143,000

Total Connection Charge to Customer = £143,000

Example 6: A new connection where the Minimum Scheme is a new substation looped into existing HV network.

Purpose: Simple example of looped connection, Extension Assets only, so charged in full to the Customer.

In this variation to Example 5, the Customer is connected with a looped connection, as illustrated in the following diagram. The Minimum Scheme is a new 800kVA substation looped into existing 11kV network.

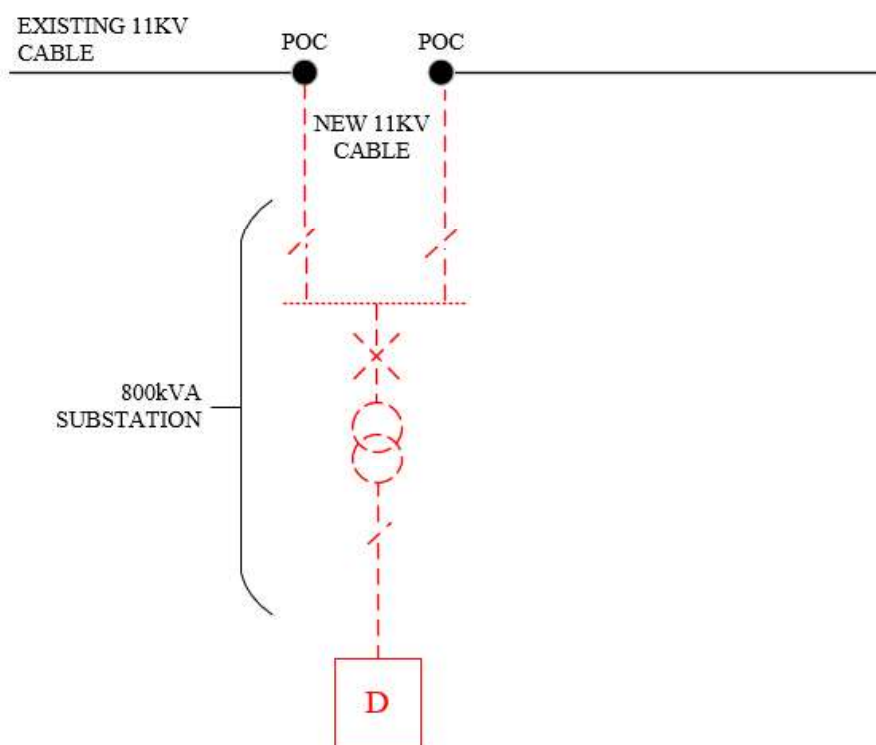

The Connection Charge for this Scheme is calculated as follows:

Extension Assets:	Cost	Apportionment	Customer Contribution
Provision and installation of 300m (2x150m) of 11kV cable looped into the network	£90,000	n/a	£90,000
800kVA transformer	£75,000	n/a	£75,000
Ring Main Unit	£25,000	n/a	£25,000
Provision and installation LV cabling	£6,000	n/a	£6,000
LV Metering Panel	£4,000	n/a	£4,000
11kV joints to network	£6,000	n/a	£6,000
Total Extension Asset Cost	£206,000		£206,000

Total cost of the work = £206,000

Total Connection Charge to Customer = £206,000

Example 7: A new connection where the Minimum Scheme is as for Example 5 but the Customer requests an enhanced connection arrangement where the substation is looped into existing HV network.

Purpose: Shows that for a Customer requested Enhanced Scheme that the Customer pays costs above the Minimum Scheme plus O&M.

In this variation to Example 5, the Customer requests an enhanced connection arrangement where the substation is looped into existing 11kV network, as illustrated in the following diagram. The Minimum Scheme is as for Example 5.

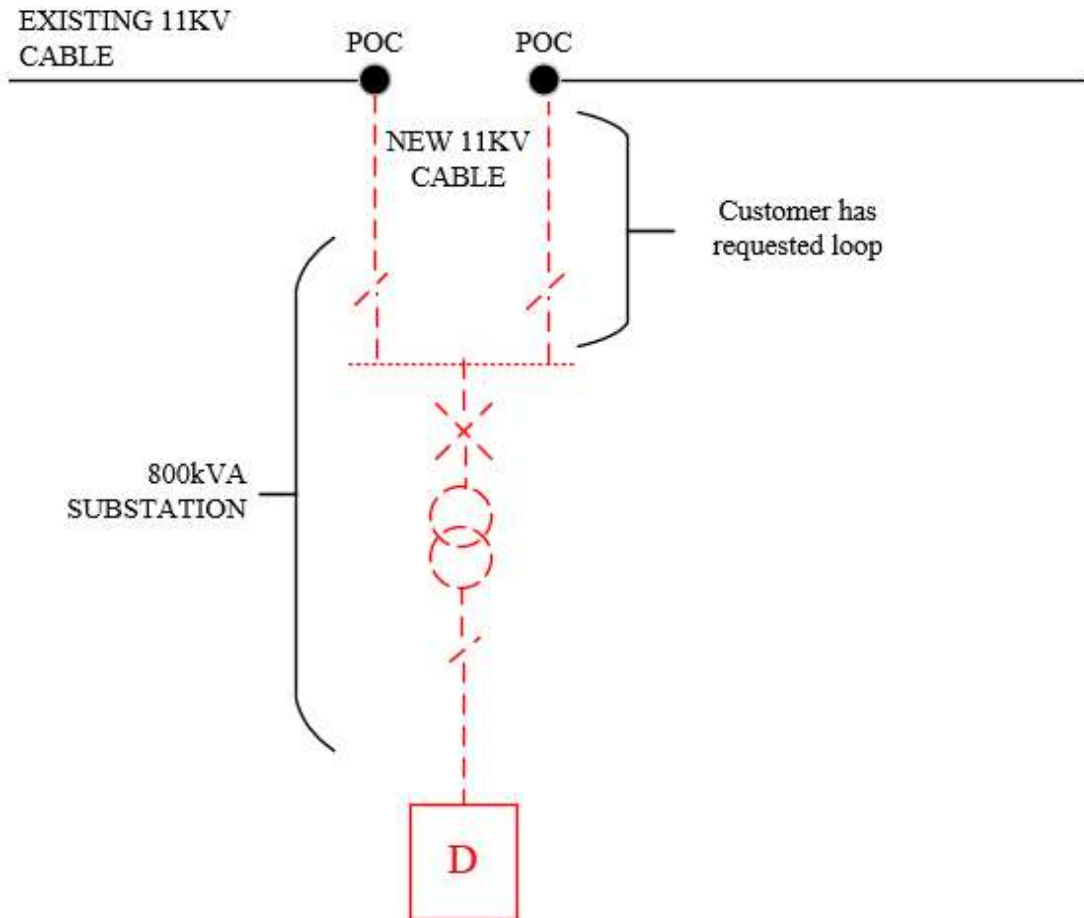

The Connection Charge for this Scheme is calculated as follows:

Extension Assets:	Cost	Apportionment	Customer Contribution
Provision and installation of 300m (2x150m) of 11kV cable looped into the network	£90,000	n/a	£90,000
800kVA transformer	£75,000	n/a	£75,000
Ring Main Unit	£25,000	n/a	£25,000
Provision and installation LV cabling	£6,000	n/a	£6,000
LV Metering Panel	£4,000	n/a	£4,000
11kV joints to network	£6,000	n/a	£6,000
Total Extension Asset Cost	£206,000		£206,000
Difference between Minimum and the actual Scheme is £63,000 (£206,000-£143,000). Operation & Maintenance @20%* of £63,000.		20%* of £63,000	£12,600
Total Extension Asset Cost incl O&M			£218,600

*Note, the 20% Operation and Maintenance percentage has been used for illustrative purposes only

Total cost of the work = £206,000

Total Connection Charge to Customer = £206,000 + £12,600 = £218,600

Example 8: A new connection where the Minimum Scheme is as for Example 5 but we request an Enhanced Scheme where the substation is looped into the existing HV network.

Purpose: Shows that for a DNO requested Enhanced Scheme that the DNO pays for all costs above Minimum Scheme.

In this variation to Example 5, the Customer is connected with a looped connection, as illustrated in the following diagram. The Minimum Scheme is as for Example 5 but we request an Enhanced Scheme where the substation is looped into the existing 11kV network.

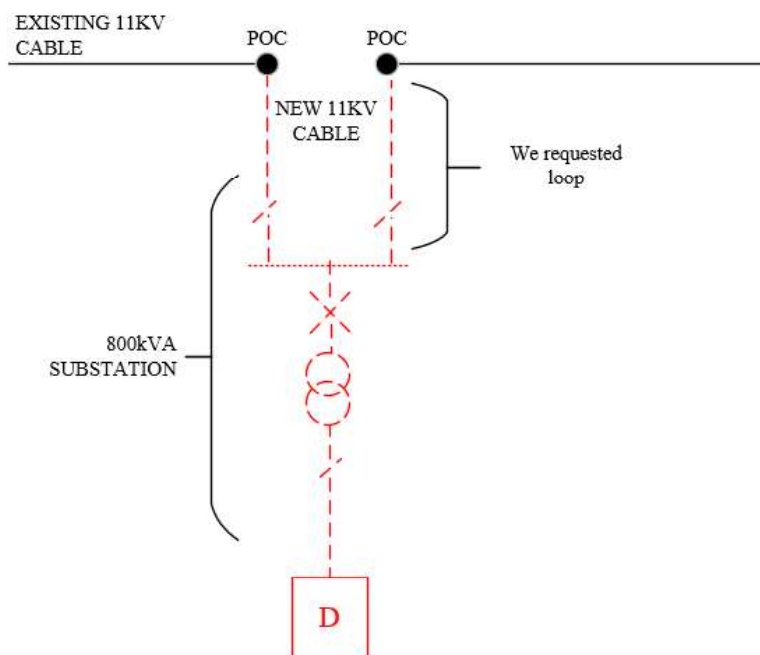

The Connection Charge for this Scheme is calculated as follows:

Extension Assets:	Cost	Apportionment	Customer Contribution
Provision and installation of 300m (2x150m) of 11kV cable	£90,000	Minimum Scheme charges apply	£45,000
800kVA transformer	£75,000	Minimum Scheme charges apply	£85,000
Ring Main Unit	£25,000		
Provision and installation LV cabling	£6,000	n/a	£6,000
LV Metering Panel	£4,000	n/a	£4,000
11kV joints to network	£6,000	Minimum Scheme charges apply	£3,000
Total Extension Asset Cost	£206,000		£143,000

Total cost of the work = £206,000

Total Connection Charge to Customer = £143,000

Example 9: An additional load application requiring a new connection from the HV network and Reinforcement.

Purpose: To demonstrate the treatment of Reinforcement cost for a Demand Connection that drives Reinforcement.

A Customer requests to increase the Maximum Capacity of their existing LV connection from 200kVA to 850kVA; an increase of 650kVA (the Required Capacity). The Connection is a Demand Connection.

As the Customer's existing LV connection is unable to deliver the Required Capacity a new connection will be required from the local 11kV network. This will be a non-secure connection to a secure network. The Minimum Scheme is to overlay part of the nearest 11kV circuit (Feeder 2) which only has spare capacity of 200kVA. The Reinforcement to make the capacity available requires 1200m of existing 11kV cable to be overlaid with a larger capacity cable. Costs of the disconnection of the existing LV connection have not been included in this example.

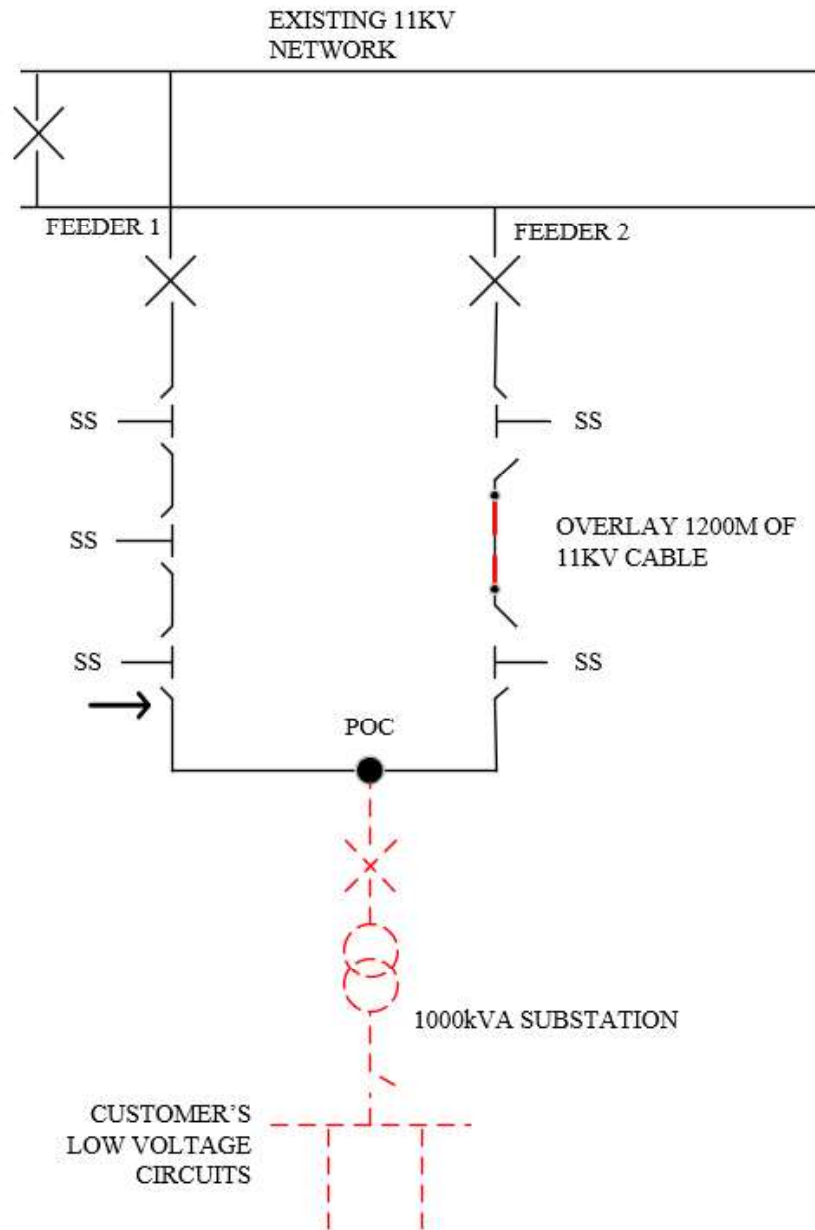

Reinforcement:

The Relevant Section of Network is the two feeder ring comprising Feeder 1 and Feeder 2.

As this connection is a Demand Connection the Customer will not be charged for Reinforcement. The Connection Charge for this Scheme is calculated as follows:

Reinforcement	Cost	Apportionment	Customer Contribution
Overlay 1200m of 11kV cable	£360,000	0%	£0
11kV Jointing	£6,000	0%	£0

Total Reinforcement Cost	£366,000		£0

Extension Assets	Cost	Apportionment	Customer Contribution
Provision and installation 11kV cable	£60,000	n/a	£60,000
1000kVA substation	£80,000	n/a	£80,000
Termination of Customer's LV cables	£4,000	n/a	£4,000
LV Metering panel	£4,000	n/a	£4,000
11kV Jointing	£3,000	n/a	£3,000
Total Extension Asset Cost	£151,000		£151,000

Total Cost of the Work = £366,000 + £151,000 = **£517,000**

Total Connection Charge to Customer = **£151,000**

Example 10: A new connection that results in a Point of Connection further away than the nearest network.

Purpose: To show that the Minimum Scheme may result in a Point of Connection that is further away than the nearest network and may result in increased Extension Asset costs that are charged in full to the Customer.

A Customer applies for a new connection with a Maximum Capacity of 100kVA.

Assessment of the local network identifies that there is an existing LV cable to the front of the development, which is fed from a 315kVA transformer. The LV cable has sufficient spare capacity for the connection; however, the transformer is at full capacity and would therefore require Reinforcement work to upgrade it from a 315kVA to 500kVA transformer.

Two design options are considered.

1. For the first option, the cost of this work is estimated to be £70,000, and the cost of the LV Mains Service is estimated to be £5,000.

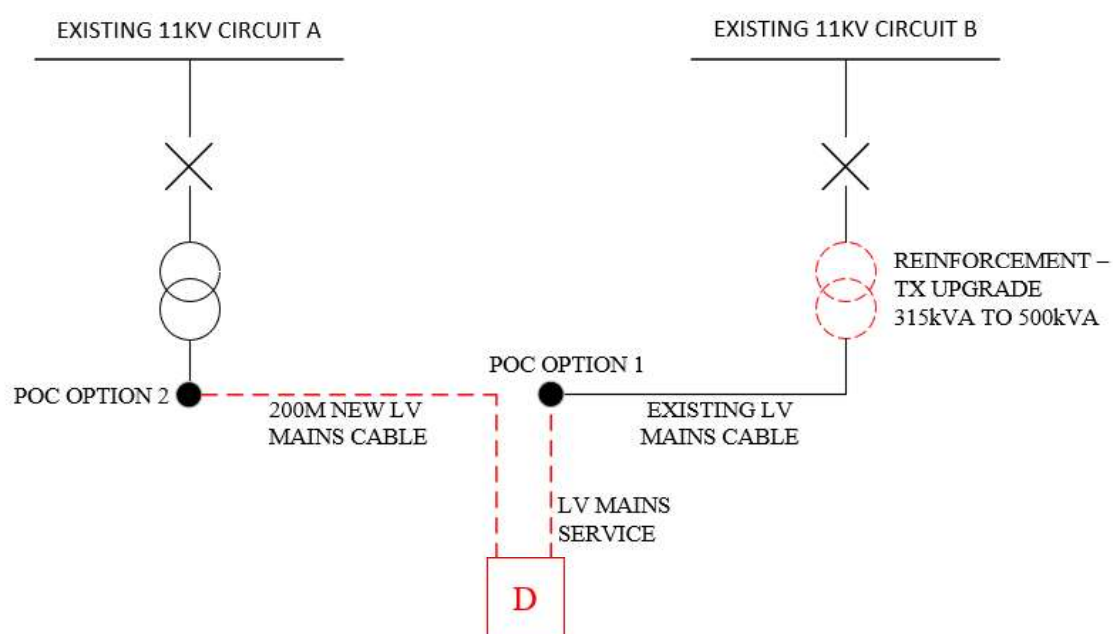

The Connection Charge for this Option 1 would be calculated as follows:

Reinforcement Assets:	Cost	Apportionment	Customer Contribution
Upgrade 315kVA transformer to 500kVA	£70,000	0%	£0
Total Reinforcement Asset Cost	£70,000		£0

Extension Assets:	Cost	Apportionment	Customer Contribution
LV Mains Service	£5,000	n/a	£5,000
Total Extension Asset Cost	£5,000		£5,000

Total cost of the work = £70,000 + £5,000 = **£75,000**

Total Connection Charge to Customer = £5,000 = **£5,000**

2. For the second option, there is a large cross-sectional LV cable 200m from the development which is fed from a 1000kVA transformer, and both the LV cable and transformer have sufficient spare capacity to provide a connection to the development without Reinforcement work. This design requires Extension Assets involving 200m of LV Cable estimated to cost £40,000 and a mains type service; the cost of the LV Mains Service is £5,000 consistent with the first option.

The Connection Charge for Option 2 would be calculated as follows:

Extension Assets:	Cost	Apportionment	Customer Contribution
200m of LV mains cable	£40,000	n/a	£40,000
LV Mains Service	£5,000	n/a	£5,000
Total Extension Asset Cost	£45,000		£45,000

Total cost of the work = **£45,000**

Total Connection Charge to Customer = **£45,000**

Option 2 has the lower overall capital cost of £45,000 (compared to £75,000 for Option 1) and therefore represents the Minimum Scheme. Whilst Option 2 results in a higher charge to the Customer, it is the overall capital cost that is used to determine the Minimum Scheme. The connection offer to the Customer would therefore be based on Option 2.

Example 11: A new Generation Connection with capacity triggered Reinforcement.

Purpose: To demonstrate the treatment of Reinforcement cost for a Generation Connection which drives Reinforcement using the Security CAF.

A Customer requests a Generation Connection with a Required Capacity for export purposes of 3MW. The Minimum Scheme requires the Reinforcement of 500m of 11kV overhead line between points A and B to provide 7.6MVA of capacity.

The POC is to the existing 11kV network at point B and it is proposed to install 500m of 11kV underground cable from the POC to the Customer's installation and this cable is treated as Extension Assets.

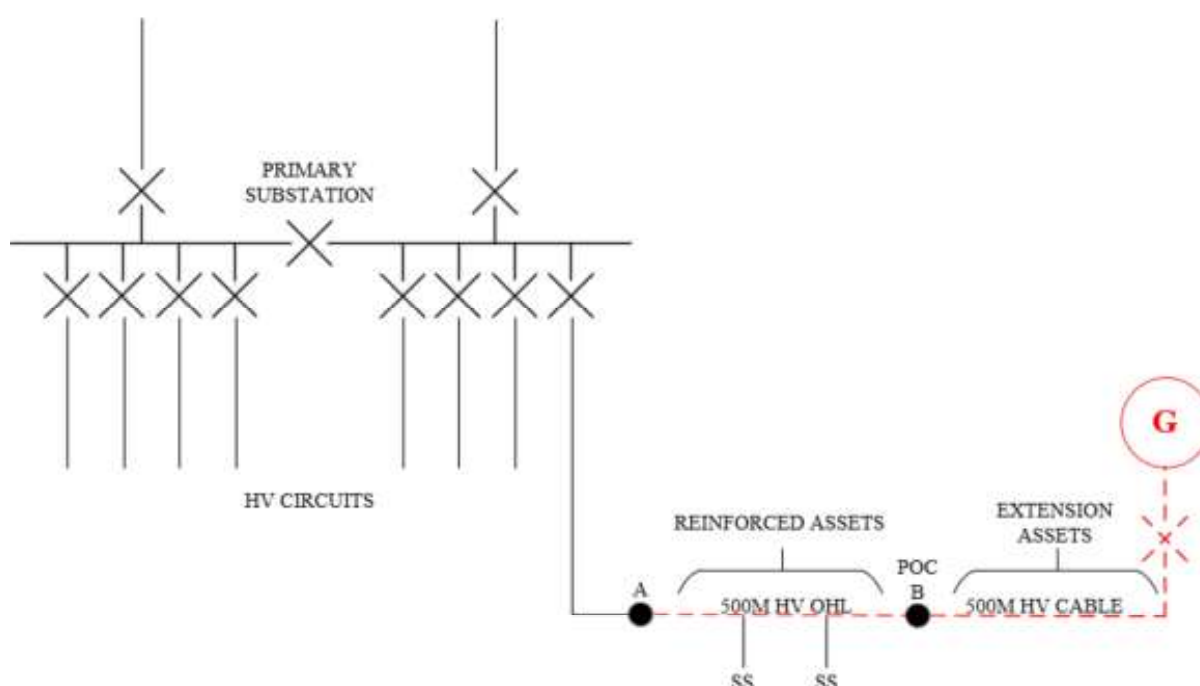
**Reinforcement:**

The Relevant Section of Network is the 11kV OHL between points A and B and the Security CAF applies. The numerator in the CAF calculation is based upon the Required Capacity of the Customer, i.e. 3MVA and the denominator is based on the New Network Capacity following Reinforcement, i.e. 7.6MVA.

The Connection Charge for this Scheme is calculated as follows:

Reinforcement:	Cost	Apportionment	Customer Contribution
Re-conductor 500m of 11kV overhead line at a higher capacity (7.6MVA)	£60,000	$\frac{3}{7.6} \times 100\%$ = 39.5%	£23,700
Total Reinforcement Cost	£60,000		£23,700

Extension Assets:	Cost	Apportionment	Customer Contribution
Installation of 500m 11kV cable	£45,000	n/a	£45,000
11kV circuit breaker at Customer's substation	£25,000	n/a	£25,000
Total Extension Asset Cost	£70,000		£70,000

Total cost of the work = £60,000 + £70,000 = **£130,000**

Total Connection Charge to Customer = £23,700 + £70,000 = **£93,700**

Example 12: A new Generation Connection with Fault Level-Triggered Reinforcement.

Purpose: To demonstrate how the Fault Level CAF calculation is applied.

A Customer wishes to connect a new generator with a Required Capacity for export purposes of 6MW. The connection of the generator requires the installation of 500m of 11kV cable and 1500m of overhead line between a new circuit breaker, added to the 11kV extensible switchgear panel at an existing primary substation and a new substation at the Customer's Premises. These assets are treated as Extension Assets.

The connection of the generator necessitates Reinforcement works to replace the 11kV switchgear at the existing primary substation with switchgear of a higher fault level rating.

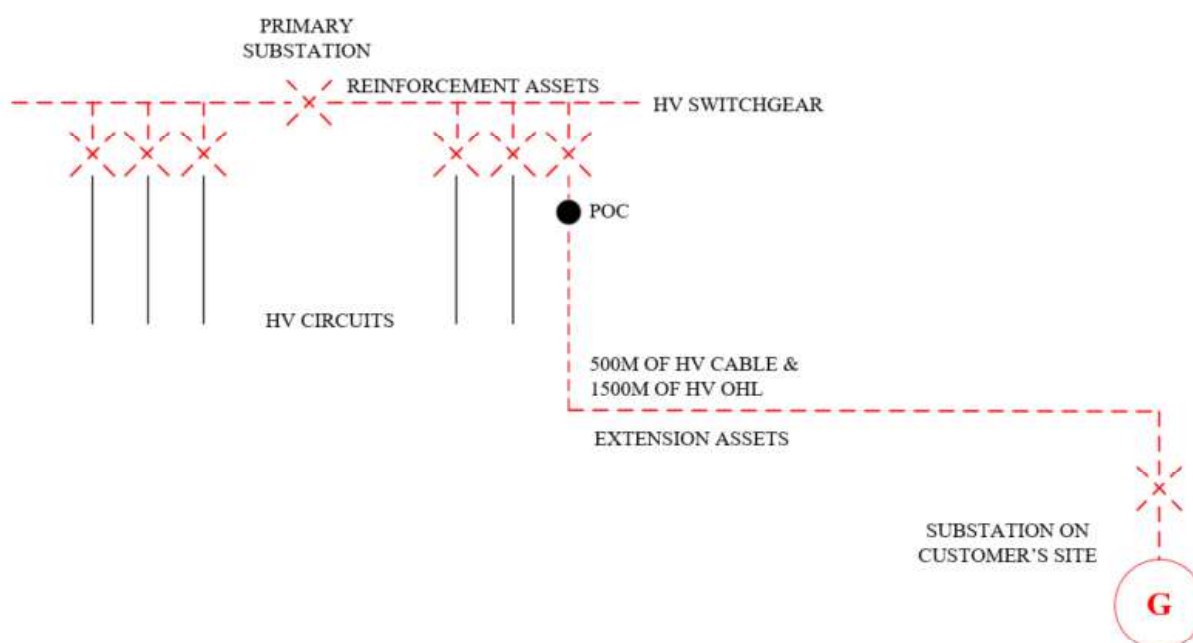
**Reinforcement:**

Fault Level CAF calculation: The numerator in the CAF calculation is based upon the Fault Level contribution from the Customer's new generator connection, in this example, 24MVA. The denominator is based upon the New Fault Level Capacity; in this Example the Fault Level capacity of the new 11kV switchboard, 315MVA.

The Connection Charge for this Scheme is calculated as follows:

Reinforcement:	Cost	Apportionment	Customer Contribution
Replacement 11kV switchboard (excluding Customer's sole use circuit breaker)	£800,000	$3 \times (24/315) \times 100\% = 22.9\%$	£182,857
Total Reinforcement Cost	£800,000		£182,857

Extension Assets:	Cost	Apportionment	Customer Contribution
Installation of a 500m 11kV cable	£150,000	n/a	£150,000
Installation of a 1500m 11kV overhead line	£120,000	n/a	£120,000
11kV circuit breaker at Customer substation	£25,000	n/a	£25,000
Total Extension Asset Cost	£325,000		£325,000

Total cost of the work = £800,000 + £325,000 = **£1,125,000**

Total Connection Charge to Customer = £182,857 + £325,000 = **£507,857**

Example 13 A new Generation Connection that requires Reinforcement involving both Security and Fault Level CAFs.

Purpose: To demonstrate Reinforcement charging principles for a Generation Connection where both Security CAF and Fault Level CAF are applicable.

A Customer requests a connection to a generator with a Required Capacity for export purposes of 6MW. The Fault Level contribution at the primary substation from the generation connection is 10MVA.

The POC is to the existing 11kV network at point B and it is proposed to install 500m of 11kV underground cable from the POC to the Customer's installation. This is treated as Extension Assets.

The connection requires the Reinforcement of 500m of 11kV overhead line between points A and B for a thermal capacity requirement and the Security CAF applies. The connection also requires the replacement of the existing 11kV switchboard at the primary substation in order to increase its fault level rating from 150MVA to 350MVA and the Fault Level CAF applies. However, the new fault level will be limited by the fault level rating of the local network of 250MVA.

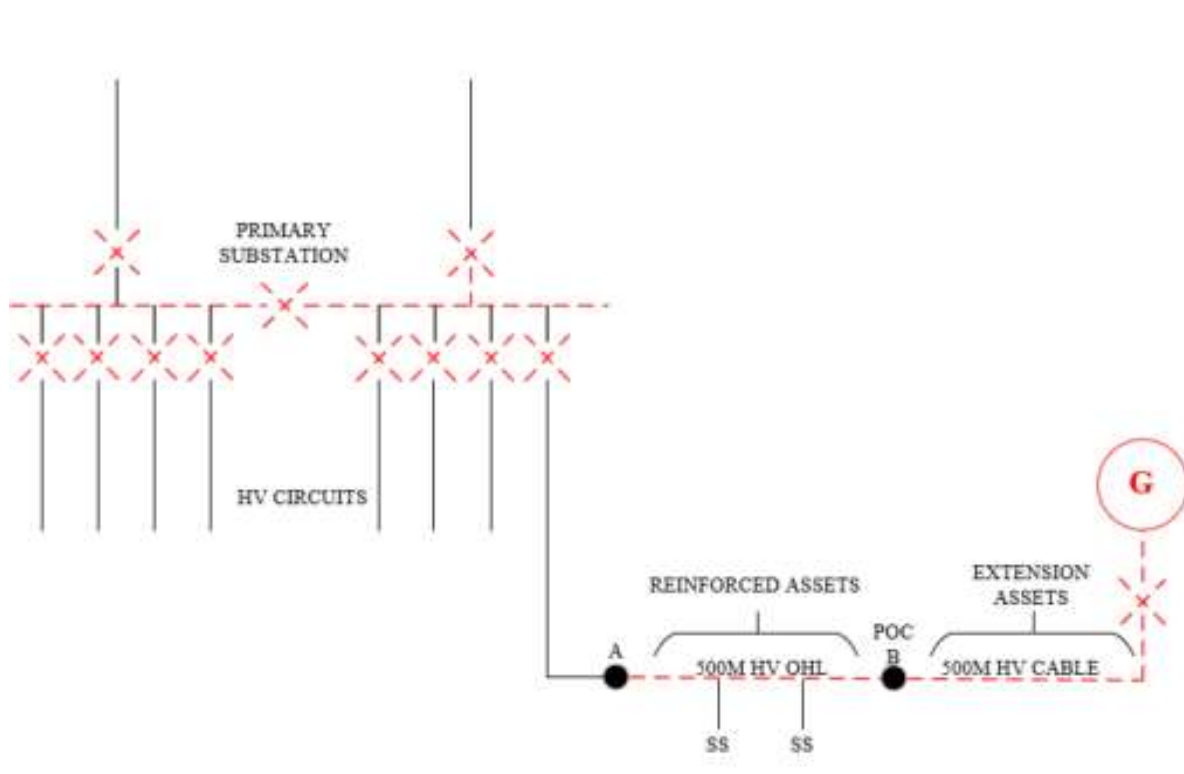

Reinforcement:

The Relevant Section of Network is the 11kV network from the primary substation to Point B.

Security CAF calculation: the numerator in the CAF calculation is based upon the Required Capacity of the Customer, i.e. 6MW. The denominator is based on the New Network Capacity following Reinforcement, which is 7.6MVA, i.e. after Reinforcement, in this particular case, the section of cable with the lowest rating.

The Relevant Section of Network is the 11kV switchboard at the primary substation.

Fault Level CAF calculation: The numerator in the CAF calculation is based upon the Fault Level contribution from the Customer's new generator connection, in this Example 10MVA. The denominator is based upon the New Fault Level Capacity, which is the lower of the Fault Level capacity of the new 11kV switchboard, 350MVA or of the local system, 250MVA in this Example.

The Connection Charge for this Scheme is calculated as follows:

Reinforcement	Cost	Apportionment	Customer Contribution
Re-conductor of 500m of 11kV overhead line	£20,000	$6/7.6 \times 100\% = 78.9\%$ Security CAF	£15,789
Replacement 11kV switchboard	£800,000	$3 \times (10/250) \times 100\% = 12.0\%$ Fault Level CAF	£96,000
Total Reinforcement Cost	£820,000		£111,789

Extension Assets	Cost	Apportionment	Customer Contribution
Installation of 500m 11kV cable	£150,000	n/a	£150,000
11kV circuit breaker at Customer's substation	£12,000	n/a	£12,000
11kV pole top termination	£2,500	n/a	£2,500
Total Extension Asset Cost	£164,500		£164,500

Total cost of the work: = £820,000 + £164,500 = **£984,500**

Total Connection Charge to Customer = £111,789 + £164,500 = **£276,289**

Example 14 A new Generation Connection with Reinforcement at a voltage above that of the Point of Connection.

Purpose: To illustrate that a Generation Connection does not contribute to Reinforcement costs at a voltage level above the connection voltage.

A Customer requests a Generation Connection with a Required Capacity for export purposes of 6.0MW. A new single circuit cable will be required to connect the Customer to the existing 11kV network. There is sufficient spare capacity on the existing 11kV network main but the existing 7.5MVA transformer at the local 11kV/33kV substation is fully loaded.

The Minimum Scheme is to provide a new 250m 11kV cable from the POC which is treated as Extension Assets. The connection also requires the replacement of the 7.5MW transformer at the local substation with a 10MVA transformer and is treated as Reinforcement. The 11kV and 33kV switchgear either side of the transformer also requires replacement due to exceedance of its thermal capacity.

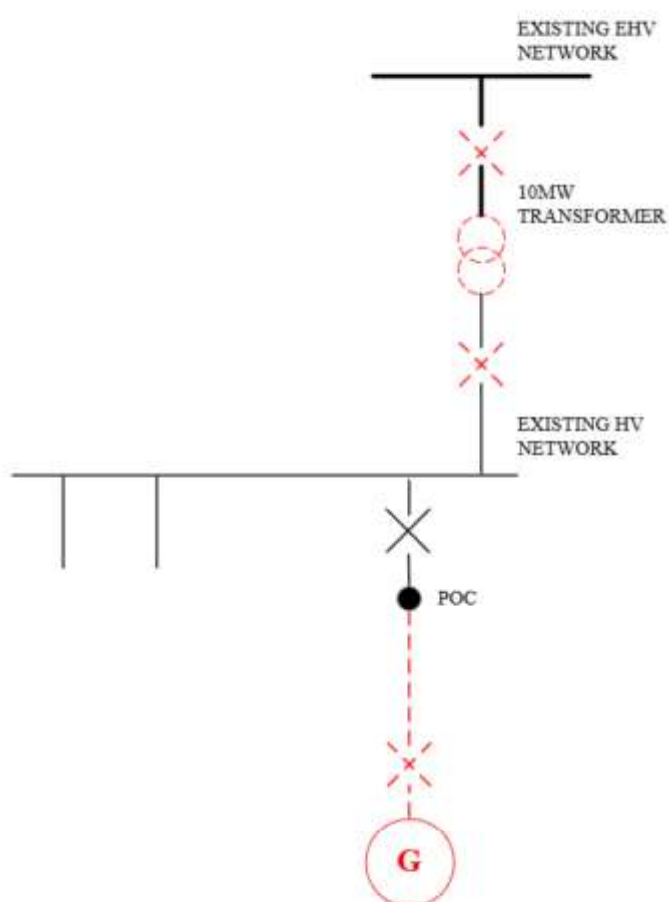

Reinforcement:

Security CAF calculation: The numerator in the CAF calculation is based upon the Required Capacity of the Customer, which is 6MW. The denominator is based on the New Network Capacity following Reinforcement, which is 10MVA.

Reinforcement is required at both the 11kV and 33kV levels, however the CAF is only required at the same voltage of connection, which in this case is 11kV.

The Connection Charge for this Scheme is calculated as follows:

Reinforcement:	Cost	Apportionment	Customer Contribution
11kV Jointing	£3,000	6/10 x 100% = 60% Security CAF	£1,800
11kV circuit breaker	£30,000	6/10 x 100% = 60% Security CAF	£18,000
33kV circuit breaker	£80,000	0%	£0
Transformer replacement	£1,000,000	0%	£0
Total Reinforcement Cost	£1,113,000		£19,800

Extension Assets:	Cost	Apportionment	Customer Contribution
Install 200m of 11kV cable	£60,000	n/a	£60,000
11kV circuit breaker at Customer's substation	£25,000	n/a	£25,000
11kV Jointing	£3,000	n/a	£3,000
Total Extension Asset Cost	£88,000		£88,000

Total cost of the work = £1,113,000 + £88,000 = **£1,201,000**

Total Connection Charge to Customer = £19,800 + £88,000 = **£107,800**

Example 15: A new Generation Connection where switchgear extension is not possible and switchgear replacement is needed.

Purpose: Illustrate Exception 4, if switchgear extension not possible, then treated as Extension Assets and costs are charged in full to the Customer.

This example demonstrates the application of Exception 4 (paragraph 1.25).

A Customer requests to connect a new generator with a Required Capacity for export purposes of 3MW. The connection of the generator requires the installation of the works as provided in Example 13 above. In this scenario, however, there is no Fault Level issue but, as the connection cannot be facilitated by an extension of the existing switchgear equipment in our primary substation, a full replacement of the existing switchgear installation is required. As no capacity is added to the existing shared use distribution network, the Customer will be required to fund the full cost of the switchgear installation replacement.

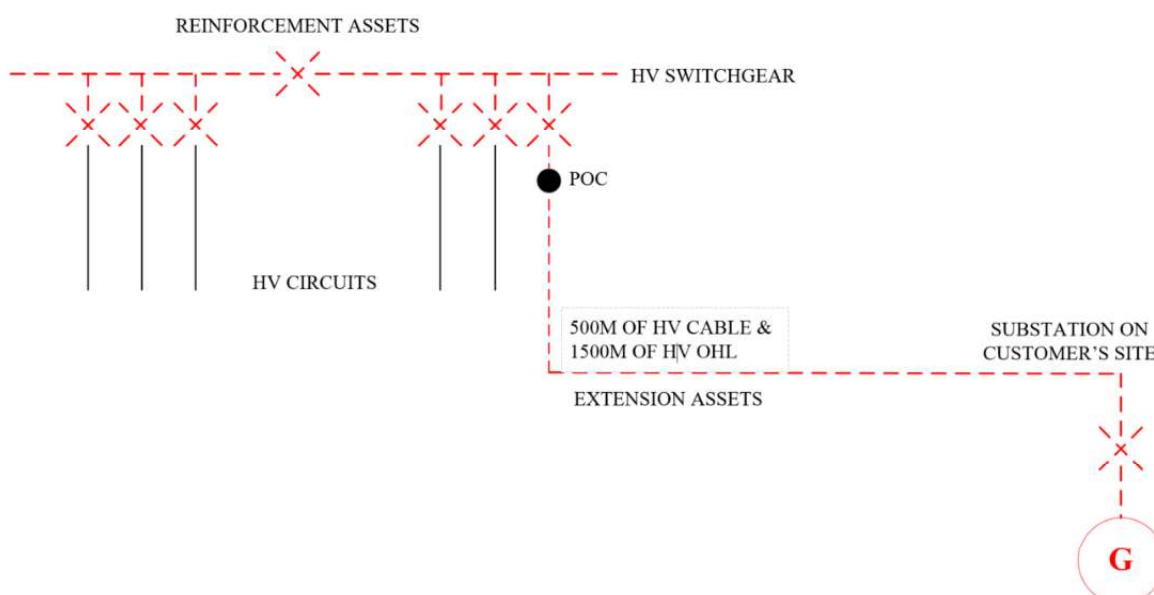

The existing switchgear had fault level rating of 250MVA. The company no longer uses switchgear with a fault level rating of 250MVA, so uses the closest equivalent switchgear used by it as standard, which has a slightly higher rating. Whilst the replacement switchgear increases the fault level capacity and could be considered Reinforcement, in this case this is due solely to the fault level rating of the standard equipment used by the company being higher than the fault level rating of the existing switchgear. The increase in fault level capacity is not required to connect the Customer. Therefore, Exception 4 (Paragraph 1.25) applies and the switchgear is considered Extension Assets and its costs will be charged in full to the Customer.

The Connection Charge for this Scheme is calculated as follows:

Extension Assets:	Cost	Apportionment	Customer Contribution
Installation of a 500m 11kV cable	£150,000	n/a	£150,000
Installation of a 1500m 11kV overhead line	£120,000	n/a	£120,000
11kV circuit breaker at Customer substation	£25,000	n/a	£25,000
Replacement 11kV switchboard	£450,000	n/a	£450,000
New Extension Asset circuit breaker	£25,000	n/a	£25,000
Total Extension Asset Cost	£770,000		£770,000

Total cost of the work = £770,000

Total Connection Charge to Customer = £770,000

Example 16: A new Storage Connection that triggers Reinforcement.

Purpose: To show that Storage, when not co-located with other demand, is treated as a Generation Connection for the purposes of charging and any Reinforcement at the same Voltage of the POC will be charged, irrespective of whether the Reinforcement is due to the import or the export.

A Customer requests to connect a Battery with a Required Capacity of 3MW export and 3MVA import. The Minimum Scheme requires the Reinforcement of 500m of 11kV overhead line between points A and B to provide 7.6MVA of capacity.

The POC is to the existing 11kV network at point B and it is proposed to install 500m of 11kV underground cable from the POC to the Customer's installation and this cable is treated as Extension Assets.

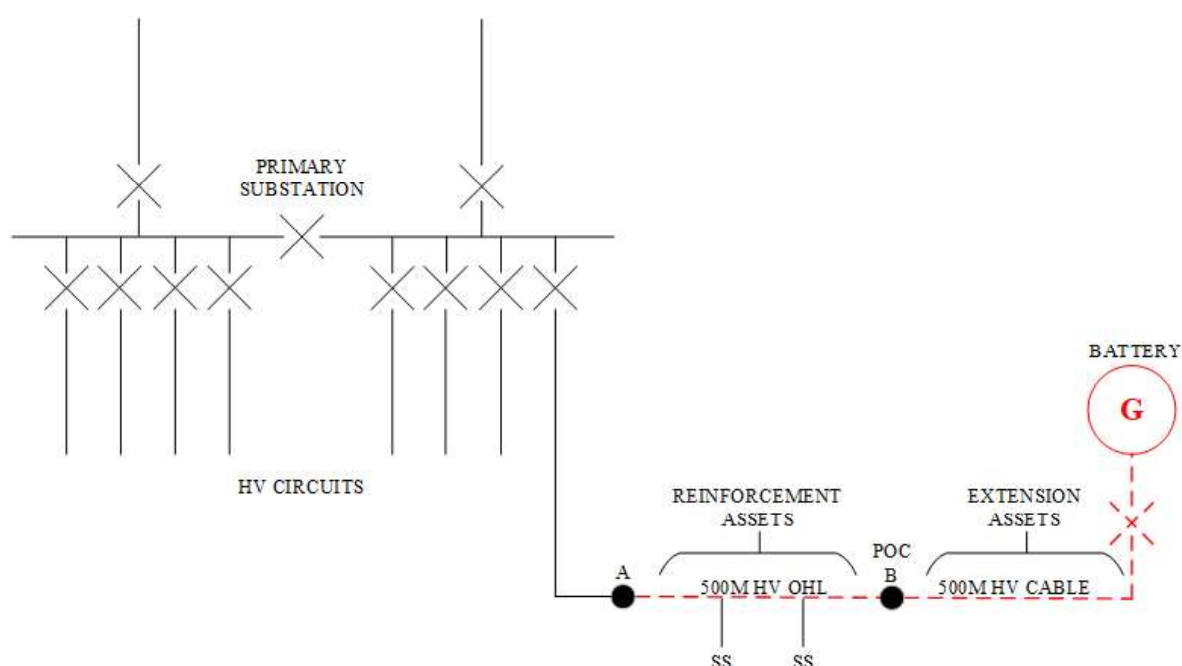
**Reinforcement:**

The Relevant Section of Network is the 11kV OHL between points A and B and the Security CAF applies. The numerator in the CAF calculation is based upon the Required Capacity of the Customer. In this instance, the reinforcement is driven by the Required Capacity for import, i.e. 3MVA and the denominator is based on the New Network Capacity following Reinforcement, i.e. 7.6MVA.

The Connection Charge for this Scheme is calculated as follows:

Reinforcement:	Cost	Apportionment	Customer Contribution
Re-conductor 500m of 11kV overhead line at a higher capacity (7.6MVA)	£60,000	$3/7.6 \times 100\%$ = 39.5%	£23,700
Total Reinforcement Cost	£60,000		£23,700

Extension Assets:	Cost	Apportionment	Customer Contribution
Installation of 500m 11kV cable	£45,000	n/a	£45,000
11kV circuit breaker at Customer's substation	£25,000	n/a	£25,000
Total Extension Asset Cost	£70,000		£70,000

Total cost of the work = £60,000 + £70,000 = **£130,000**

Total Connection Charge to Customer = £23,700 + £70,000 = **£93,700**

Example 17: A new connection that is connected by Reinforced assets

Purpose: To demonstrate the application of Exception 5 where the Customer needs to pay for the assets that connect them to the existing network

A new housing development has a Required Capacity of 1MVA to serve 450 plots. The local 11kV feeder has a network capacity of 7.7MVA based upon the limitation of the existing 400 Amp circuit breakers at Primary Substation A. The existing load on the circuit is 7.6MVA. The new load will be connected to the existing 11kV feeder from Primary Substation A with 100m of 11kV cable from POC A to the point D at the boundary of the site and provide interconnection with 700m of 11kV cable from POC B at Primary Substation B to the boundary of the site at point C. In this example:

- 200m of 11kV cable on site (between points C and D) is required to provide connectivity within the development and is considered to be Extension Assets.
- 100m of 11kV cable from POC A to the point D.
- 700m of 11kV cable from POC B to the point C.

The Minimum Scheme requires the site to be connected onto the existing network. In this case the lowest cost feeder is the 11kV cable from A to D and is treated as an Extension Asset. The alternative connection to POC B at Primary Substation B is required to meet the minimum network security requirements and is treated as Reinforcement.

The figure below shows the proposed network.

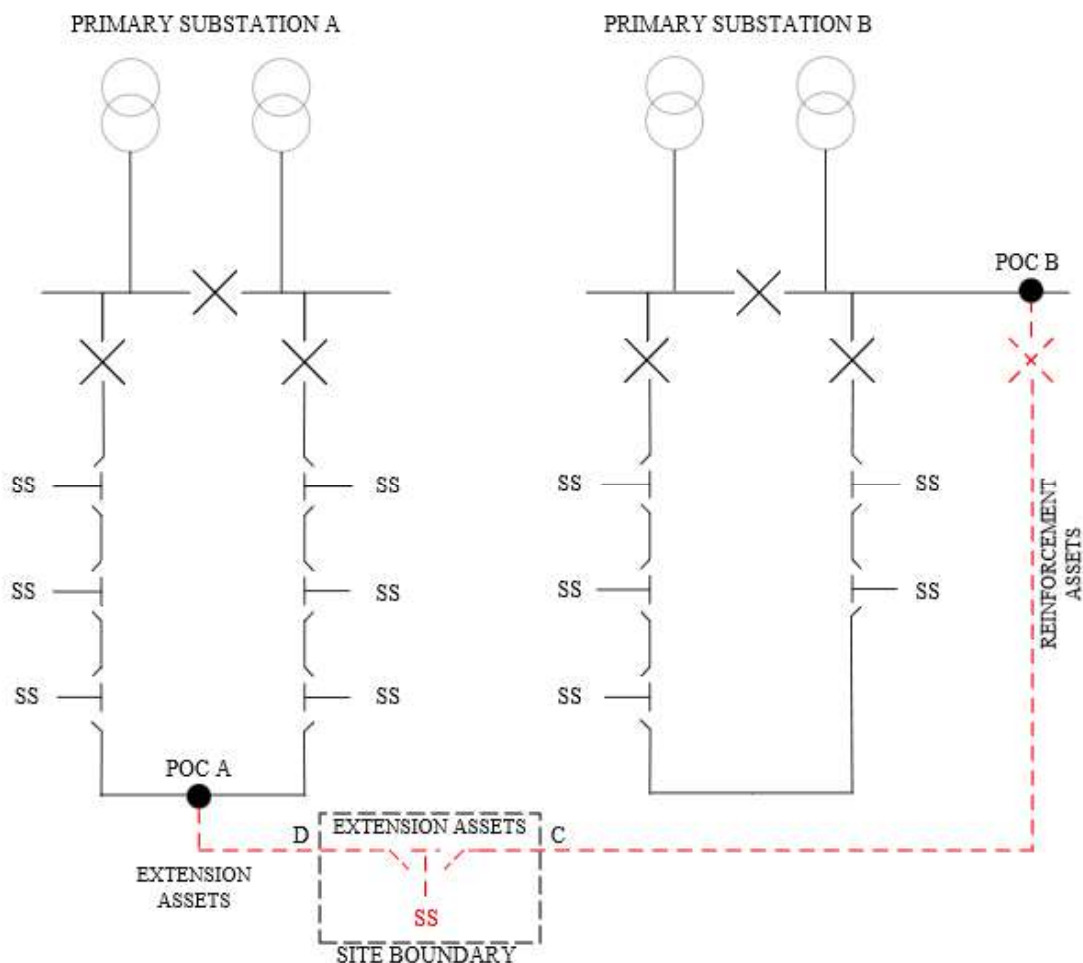

Reinforcement:

The 700m of 11kV cable from POC B at Primary Substation B to point C is treated as reinforcement however as this is a demand connection the reinforcement work is funded by us.

The Connection Charge for this Scheme is calculated as follows:

Reinforcement:	Cost	Apportionment	Customer Contribution
1 new HV Circuit Breaker from POC B	£30,000	0%	£0
2 by HV closing joints	£6,000	0%	£0
700m of HV cable from POC B to point C	£210,000	0%	£0
Total Reinforcement Cost	£246,000		£0

Extension Assets:	Cost	Apportionment	Customer Contribution
100m of HV cable from POC A to point D	£30,000	n/a	£30,000
One 1000kVA Substation	£75,000	n/a	£75,000
On site LV mains and services	£24,900	n/a	£24,900
2 by HV cable box terminations	£24,000	n/a	£24,000
Total Extension Asset Cost	£153,900		£153,900

Total cost of the work = £246,000 + £153,900 = **£399,900**

Total Connection Charge to Customer = £153,900 = **£153,900**

Example 18: A new connection of a development

Purpose: To demonstrate the application of Exception 6 where the Customer pays for assets within the site boundary.

This example demonstrates the application of Exception 6 (paragraph 1.27) where the Customer pays for assets within the site boundary.

A new housing development (a Demand Connection) has a Required Capacity of 2MVA to serve 900 plots. The local 11kV feeder has a network capacity of 7.7MVA based upon the limitation of the existing 400 Amp circuit breakers at Primary Substation A. The existing load on the circuit is 7.6MVA. It is therefore not possible to connect the new load to this circuit without Reinforcement works. The Minimum Scheme is to connect the new load to the new 11kV feeder from Primary Substation B and provide interconnection to an existing secure 11kV feeder from Primary Substation A. In this Example 600m of 11kV cable on site (between Points C and D) is required to provide connectivity within the development and is considered to be Extension Assets.

The three 800kVA substations are not considered to provide connection between POC A and POC B. The 600m of 11kV cable on site is additional network length to provide connectivity between multiple exit points on the Customer's site. Therefore, Exception 6 applies and the 600m of 11kV cable on site will be treated as Extension Assets and its costs will be charged in full to the Customer.

The figure below shows the proposed network.

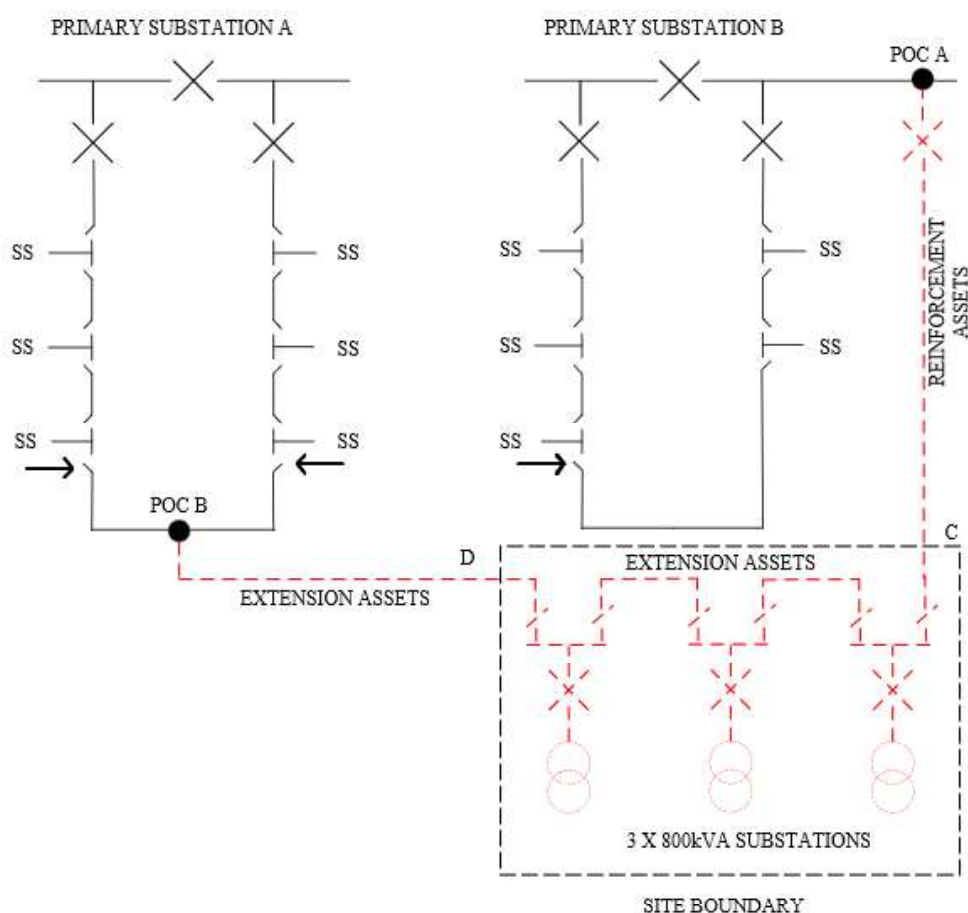

Reinforcement:

The assets connecting POC A and point C add capacity to the existing network will be treated as Reinforcement and funded by us.

The Connection Charge for this Scheme is calculated as follows:

Reinforcement:	Cost	Apportionment	Customer Contribution
1 new 11kV Circuit Breaker tailed out from Primary Substation B (POC A)	£30,000	0%	£0
2 by 11kV closing joints	£6,000	0%	£0
700m of 11kV cable from Primary Substation B to site	£210,000	0%	£0
Total Reinforcement Cost	£246,000		£0

Extension Assets:	Cost	Apportionment	Customer Contribution
600m of 11kV cable on site	£180,000	n/a	£180,000
3 by 800kVA unit Substation	£225,000	n/a	£225,000
On site LV mains and services	£24,900	n/a	£24,900
2 by 11kV cable box terminations	£24,000	n/a	£24,000
600m of 11kV cable from POC B to site	£180,000	n/a	£180,000
Total Extension Asset Cost	£633,900		£633,900

Total cost of the work = £246,000 + £633,900 = **£879,900**

Total Connection Charge to Customer = £0 + £633,900 = **£633,900**

Example 19: A new connection with remote network Reinforcement

Purpose: To show treatment where capacity is created on a different part of the network and a load transfer is required to allow the connection. Example again demonstrates which elements are Reinforcement and which are Extension Assets.

This example shows the arrangements that will apply where it is necessary to reinforce a different part of the Distribution System so that existing load may be transferred in order to release capacity for the new connection.

A Customer requests a Generation Connection with a Required Capacity of 2MW. The local 11kV feeder has a network capacity of 7.7MW based upon the limitation of the existing 400 Amp circuit breakers at Primary Substation A. The existing load on the circuit is 7.7MW. It is therefore not possible to connect the new generation to this circuit without Reinforcement works.

It is proposed to reinforce an adjacent network from primary substation B so that two existing substations may be transferred on to it from primary substation A, in order to release capacity to accommodate the new connection. Primary Substation B has sufficient spare capacity to accommodate the two existing substations. A new circuit breaker is to be installed at Primary Substation B and a new 11kV feeder (also rated at 7.7MW) is to be installed between points A – B and between points E – F for connection to the local 11kV circuit at point F. The existing circuit will be cut at point BE so that the new joints can be made. This will convert the Primary Substation B network from a two-feeder to a three-feeder network. The total new cable length between points A – B and points E - F is 500m. The network will be reconfigured by the installation of two short straps C – D and G - H in order to maintain connectivity.

This Reinforcement will allow a POC to be taken from the local 11kV circuit to supply the new generation. The newly installed cable to connect the generation from the POC is 1200m long. The above work represents the Minimum Scheme to provide connections to the new site.

The figure below shows the original network.

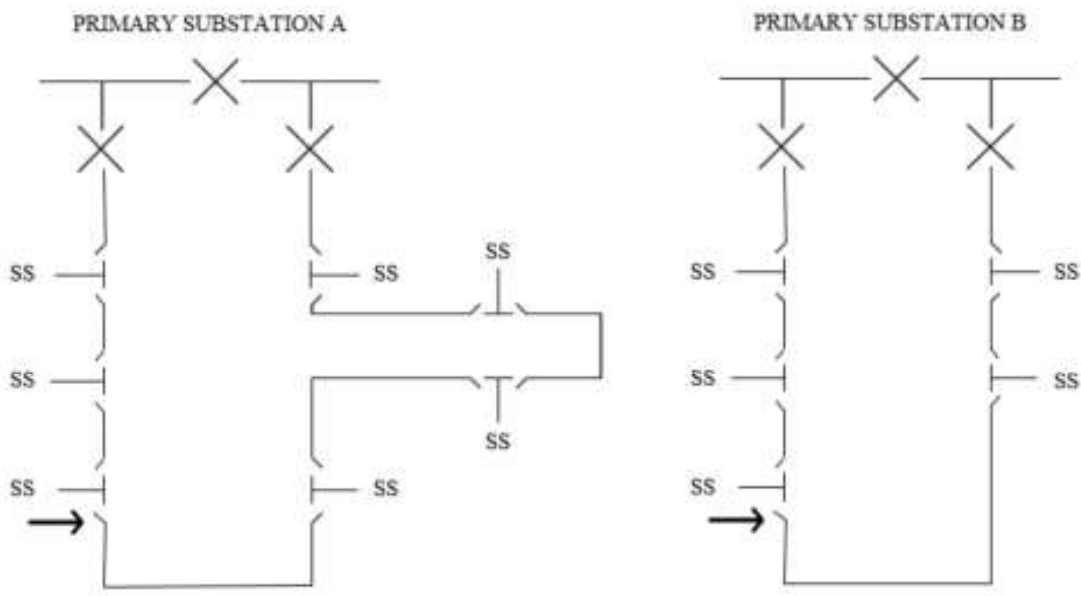

The figure below shows the proposed network.

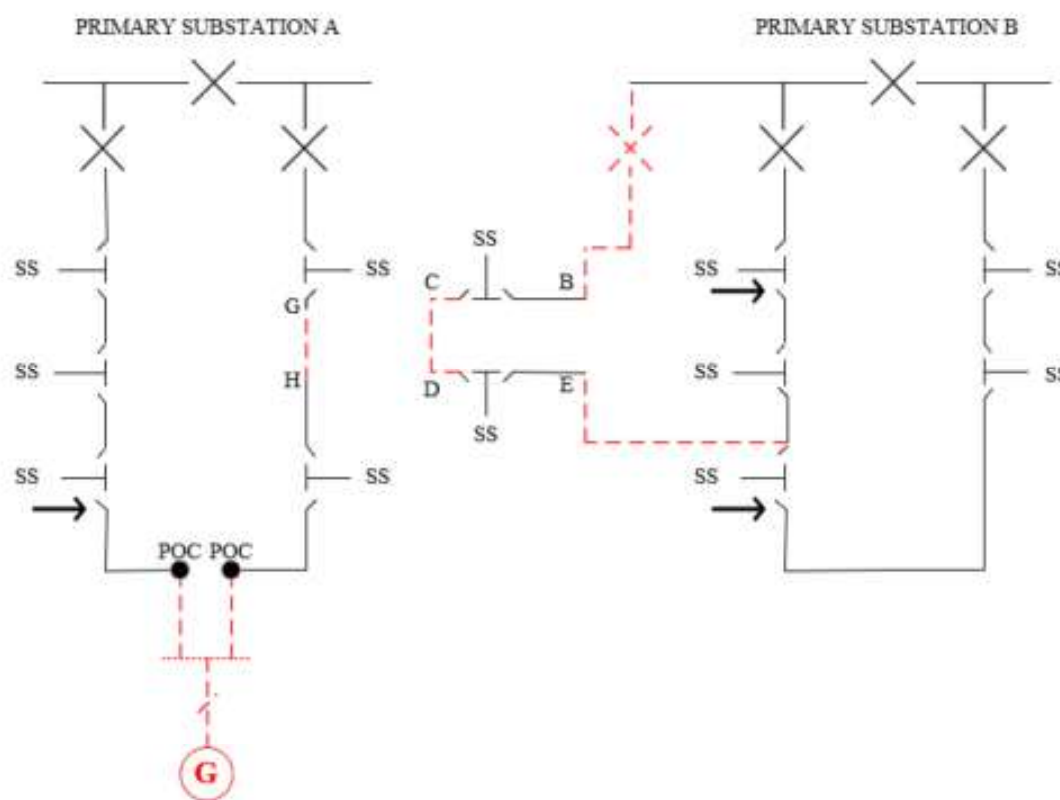

Reinforcement:

The Relevant Section of Network is the three-feeder network from Primary Substation B which supplies the loads on the existing two feeders from Primary Substation B as well as the loads at points C and D transferred from the network from the Primary Substation A. The RSN does not supply the new generation in this case. The numerator in the CAF calculation is based upon the Required Capacity of the new generation, i.e. 2MW. In this case, the New Network Capacity (under N-1 conditions) following the Reinforcement works is equal to $(3 - 1) \times 7.7\text{MW} = 15.4\text{MW}$.

Fault Level CAF calculation: This Scheme does not have any significant Fault Level contribution to the existing shared use distribution network and Fault Level CAF is therefore not applicable here.

The Connection Charge for this Scheme is calculated as follows:

Reinforcement:	Cost	Apportionment	Customer Contribution
500m of 11kV cable: A-B, C-D, E-F	£150,000	$2/15.4 \times 100\% = 13\%$	£19,480
11kV Circuit Breaker at Primary Substation B	£30,000	As above	£3,896
11kV jointing at Points A,B,C,D,E,F	£18,000	As above	£2,337
Total Reinforcement Cost	£198,000		£25,713

Extension Assets:	Cost	Apportionment	Customer Contribution
1200m of 11kV cable inc. strap at G – H	£360,000	n/a	£360,000
3 by 800kVA distribution substations	£225,000	n/a	£225,000
On site LV mains and services	£24,900	n/a	£24,900
4 by 11kV closing joints at POC and at points G,H	£12,000	n/a	£12,000
Total Extension Asset Cost	£621,900		£621,900

Total cost of the work = £198,000 + £621,900 = **£819,900**

Total Connection Charge to Customer = £25,713 + £621,900 = **£647,613**

Example 20: A new connection with load transfer

Purpose: Variation to Example 19 where a load transfer is required to free up capacity but no new capacity is created and demonstrates why elements become Extension Assets.

This variation of Example 19 shows the arrangements that will apply where it is necessary to reconfigure the Distribution System so that existing demand may be transferred in order to release capacity for the new connection.

A new housing development has a Required Capacity of 2MVA to serve 900 plots. The local 11kV feeder has a network capacity of 7.7MVA based upon the limitation of the existing 400 Amp circuit breakers at Primary Substation A. The existing load on the circuit is 7.6MVA. It is therefore not possible to connect the new load to this circuit as presently configured.

The figure below shows the original network.

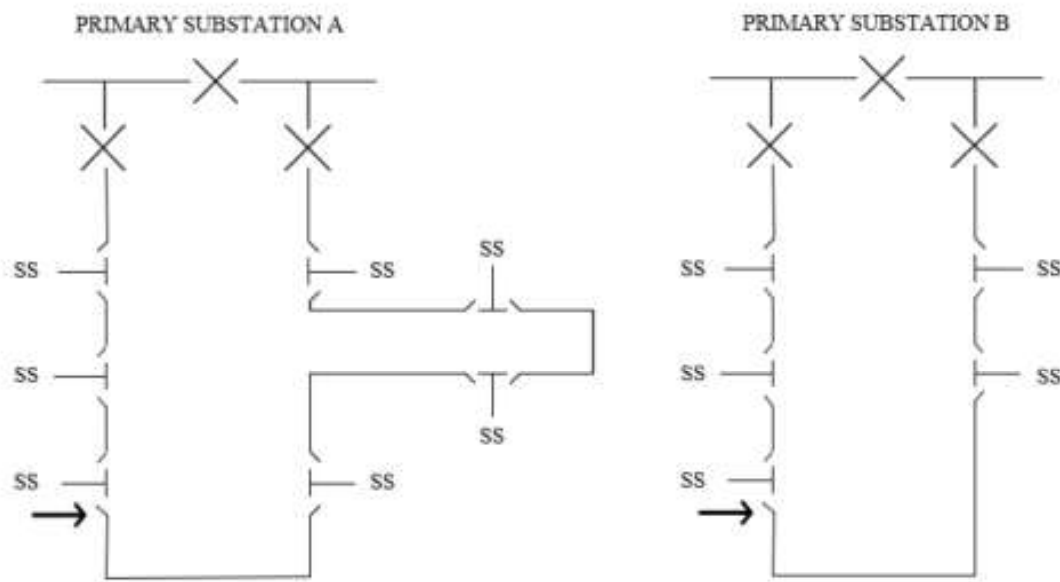

The figure below shows the proposed network.

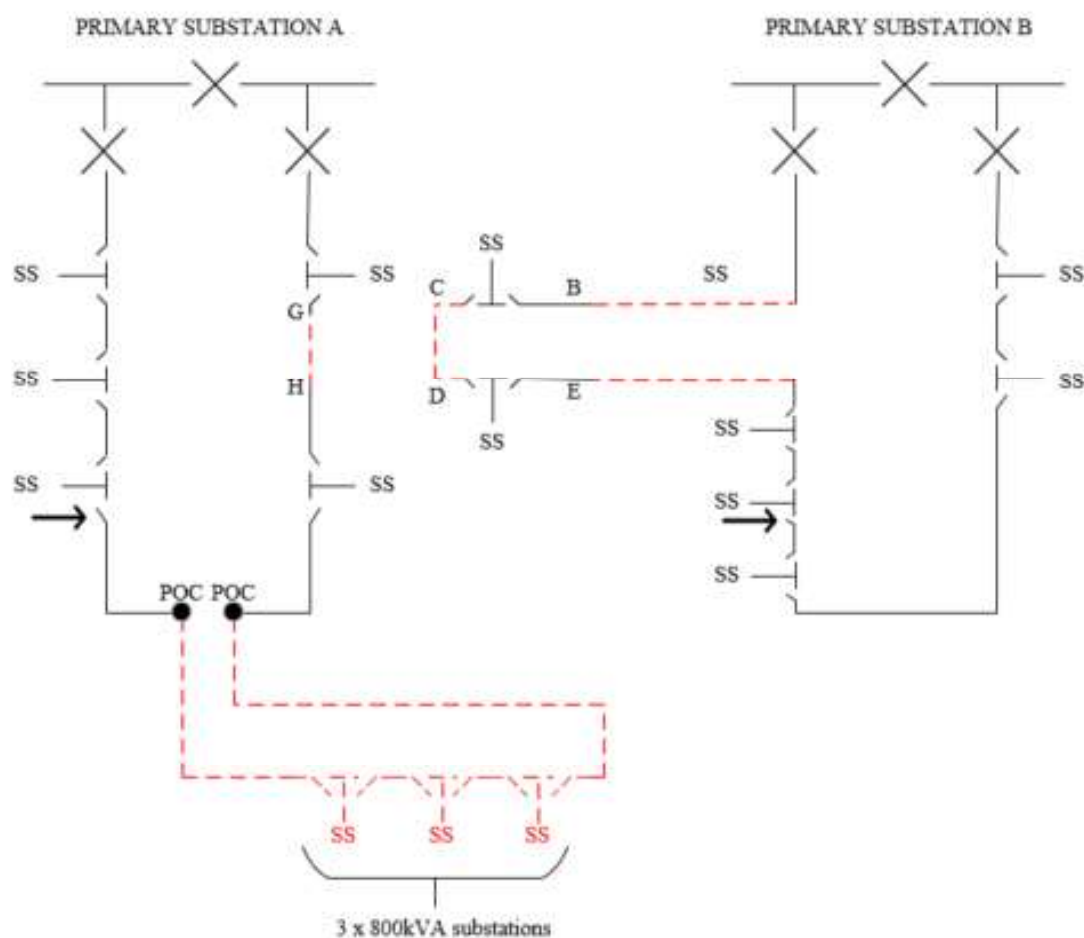

Reinforcement:

It is proposed to reconfigure the Distribution System such that two existing substations may be transferred on to an adjacent network, in order to release capacity so that the new connections can be made. Primary Substation B has sufficient spare capacity to accommodate the two existing substations. New cables are to be installed between points A – B and between points E – F. The existing circuit will be cut at point B & E so that the new joints can be made. The total new cable length between points A – B and points E - F is 100m. The network will be reconfigured by the installation of two short straps C – D and G - H in order to maintain connectivity. As this work involves the transfer of capacity there is no Reinforcement work required.

This transfer of existing demand will allow a POC to be taken from the local 11kV circuit to connect the new development. The newly installed cable to connect the development from the POC is 1200m long. Three 800kVA distribution substations are to be established onsite. The above work represents the Minimum Scheme to provide connections to the new site.

The Connection Charge for this Scheme is calculated as follows:

Extension Assets:	Cost	Apportionment	Customer Contribution
1300m of 11kV cable including A-B, C-D, E-F, G-H and from POC to the development	£390,000	n/a	£390,000
3 by 800kVA distribution substations	£225,000	n/a	£225,000
On site LV mains and services	£24,900	n/a	£24,900
10 by 11kV closing joints at POC and at points A,B,C,D,E,F,G,H	£30,000	n/a	£30,000
Total Extension Asset Cost	£669,900		£669,900

Total cost of the work = £669,900

Total Connection Charge to Customer = £669,900

Example 21: A new Generation Connection with an Enhanced Scheme at the DNO's request.

Purpose: To show how the Security CAF calculation is applied where the DNO requests an Enhanced Scheme.

Please refer to Example 11, which is the Minimum Scheme for this project. In this example, a Customer requests a Generation Connection with a Required Capacity for export purposes of 3MW. The Minimum Scheme requires the Reinforcement of 500m of 11kV overhead line between points A and B to provide 7.6MVA of capacity. However, the DNO has decided to install an Enhanced Scheme by increasing the capacity of the 11kV overhead line to 13MVA.

The POC is to the existing 11kV network at point B and it is proposed to install 500m of 11kV underground cable from the POC to the Customer's installation.

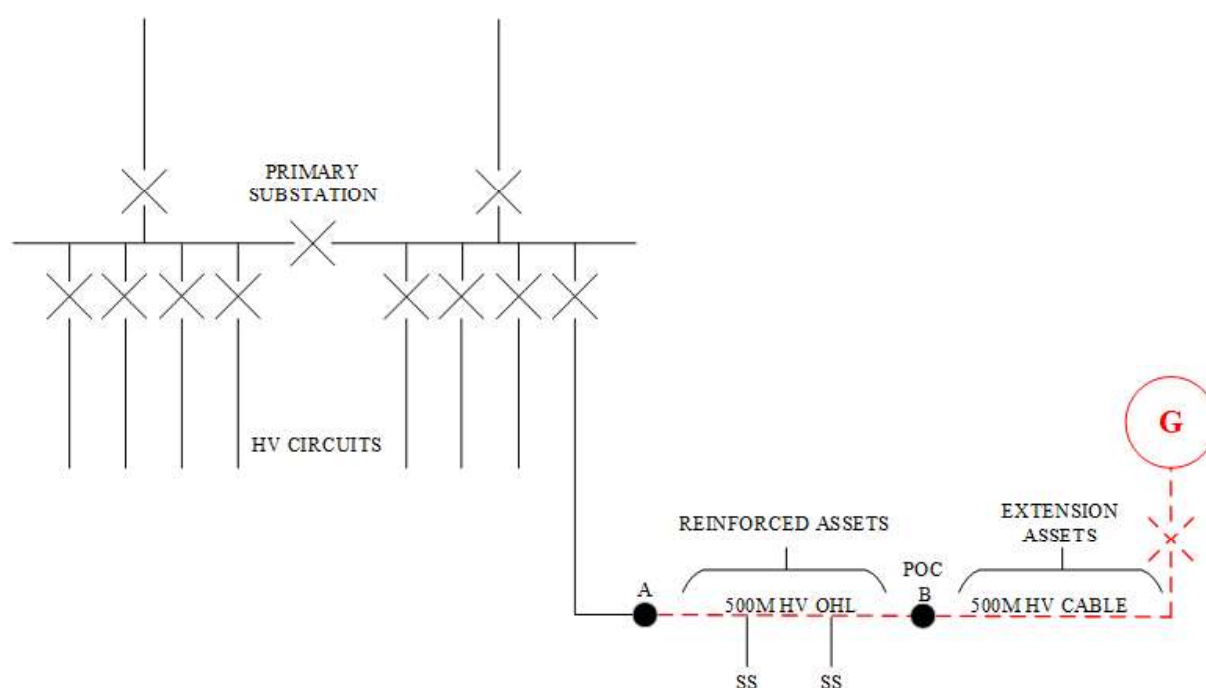
**Reinforcement:**

The Relevant Section of Network is the 11kV OHL between points A and B

Security CAF calculation: The numerator in the CAF calculation is based upon the Required Capacity of the new generation, i.e. 3MW. In this example the DNO has decided to install an Enhanced Scheme and the Connection Charge that will apply will be the lower of the Connection Charge associated with the Minimum Scheme (see Example 11) and the Enhanced Scheme. The numerator in the CAF calculation is based upon the Required Capacity of the Customer, i.e. 3MW and the denominator is based on the Enhanced Scheme New Network Capacity following Reinforcement, i.e. 13MVA.

Fault Level CAF calculation: This Scheme does not have any significant Fault Level contribution to the existing shared use distribution network so the Fault Level CAF is therefore not applicable here.

The Connection Charge for this Scheme is calculated as follows:

Reinforcement:	Cost	Apportionment	Customer Contribution
Re-conductor 500m of 11kV overhead line at a higher capacity (13MVA)	£70,000	$3/13 \times 100\%$ = 23.1%	£16,170
Total Reinforcement Cost	£70,000		£16,170

Extension Assets:	Cost	Apportionment	Customer Contribution
Installation of 500m 11kV cable	£45,000	n/a	£45,000
11kV circuit breaker at Customer's substation	£25,000	n/a	£25,000
Total Extension Asset Cost	£70,000		£70,000

Total cost of the work = £70,000 + £70,000 = **£140,000**

Total Connection Charge to Customer = £16,170 + £70,000 = **£86,170**

Example 22: A new Generation Connection on a meshed HV distribution system requiring Reinforcement.

Purpose: To show that a contribution is required where Reinforcement is carried out at the same voltage as the Point of Connection for a Generation Connection.

A Customer requests a new Generation Connection requiring a 4MVA 11kV metered connection. The local 11kV network is of a meshed design whereby the 11kV network is supplied from single 33/11kV primary transformers via 33kV radial feeds as shown below.

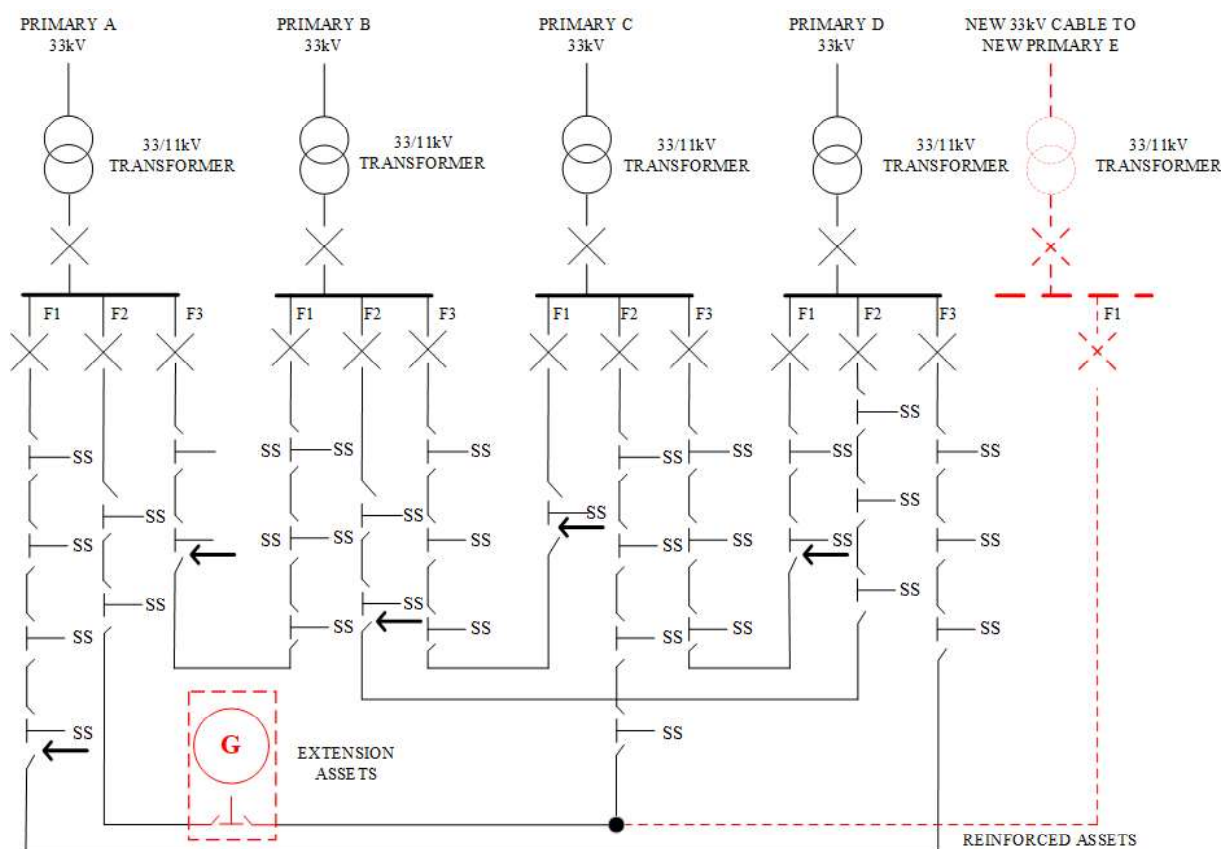

The existing network consists of four 10MVA primary transformer substations and associated 11kV switchgear. A new connection of 4MVA has been requested in the vicinity of F2 from Primary A.

The existing relevant primary transformer group is loaded to its secure capacity so the primary transformer group will require Reinforcement to enable the new connection to progress.

To provide the Required Capacity, the 11kV network will be reinforced by the installation of a new primary substation connected to the nearest 33kV circuit. The new primary substation (Primary E) will contain a 10MVA transformer, associated 11kV switchgear and a new 11kV (7.7 MVA) cable installed to interconnect into the existing 11kV network (from F2 at Primary A to F2 at Primary C).

Reinforcement:

Security CAF calculation: In this example there are two different Security CAFs applied. This is because the Relevant Section of Network is different when considering the New Network Capacity in respect of different elements of the Reinforcement works.

The Relevant Section of Network for the Reinforcement comprising the 11kV Cable Works:

For the 11kV cable assets the Relevant Section of Network is considered to be the secure three feeder 11kV network from Primary A (Feeder 2), Primary C (Feeder 2) and Primary E (Feeder 1). In this case the New Network Capacity (under secure N -1 conditions) following the Reinforcement works is equal to

$$(3 - 1) \times 7.7\text{MVA} = 15.4\text{MVA}$$

This is due to the fact that following the Reinforcement work both of the existing circuits; Primary A, Feeder 2 and Primary C, Feeder 2 can be loaded to their full capacity and will have the newly installed clean feeder from Primary E to act as a back feed to meet the requirements of P2.

The Security CAF for these assets will therefore be $4/15.4 \times 100\% = 26.0\%$

The Relevant Section of Network for the Reinforcement comprising the Primary substation assets:

In this instance the Relevant Section of Network comprises Primary A, C and E within the group that can be used to supply the Customer in normal and abnormal conditions. The New Network Capacity of this Relevant Section of Network (under secure N -1 conditions) following the Reinforcement works is equal to 17.7MVA. (10MVA from either Primary A or Primary C and 7.7MVA from Primary E which is limited by the single 11kV cable connected to it.

The Security CAF for these assets will therefore be $4/17.7 \times 100\% = 22.6\%$ towards the 11kV assets to be installed.

Due to the voltage rule, contributions will not be required towards the 33kV assets.

Fault Level CAF calculation: This Scheme does not have any significant Fault Level contribution to the existing shared use distribution network and Fault Level CAF is therefore not applicable here.

The Connection Charge for this Scheme is calculated as follows:

Reinforcement:

Reinforcement:	Cost	Apportionment	Customer Contribution
500m 11kV cable from new primary substation E	£150,000	4/15.4 X 100% = 26.0%	£39,000
1 by 11kV closing joints	£3,000	As above	£780
11kV switchgear at new Primary E	£30,000	4/17.7 X 100% = 22.6%	£6,780
Primary transformer	£6,500,000	0%	£0
2.5km of 33kV cable installation	£1,000,000	0%	£0
33kV Circuit Breaker	£80,000	0%	£0
33kV Termination	£30,000	0%	£0
Total Reinforcement Cost	£7,793,000		£46,560

Extension Assets:	Cost	Apportionment	Customer Contribution
11kV ring main unit	£25,000	n/a	£25,000
11kV metering unit	£12,000	n/a	£12,000
500m of 11kV cable	£150,000	n/a	£150,000
2 by 11kV closing joints	£6,000	n/a	£6,000
Total Extension Asset Cost	£193,000		£193,000

Total cost of the work = £7,793,000 + £193,000 = **£7,986,000**

Total Connection Charge to Customer = £46,560 + £193,000 = **£239,560**

Example 23: A non-secure Generation Connection with non-secure Reinforcement.

Purpose: To show that a contribution is required where Reinforcement is carried out at the same voltage as the Point of Connection for a Generation Connection in relation to a non-secure system.

A Customer wishes to connect a new generator (a Generation Connection) with a Required Capacity for export purposes of 5 MVA. The connection of the generator requires the installation of 1,000m of 33kV cable and a 33kV metering circuit breaker, these being Extension Assets. An existing spare circuit breaker at the substation is utilised which, in this case, is not chargeable to the Customer.

As there is insufficient capacity in the existing 24.0 MVA thermal capacity rated 33kV feeder for the new generation due to the presence of existing generation, the connection also requires the installation of a new 33kV feeder, which also has a thermal capacity of 24.0 MVA, as Reinforcement. This is the Minimum Scheme as it is cheaper to do this, to the extent as shown in the diagram below, rather than upgrade the existing 33kV feeder to the same point along it.

Reinforcement:

The numerator in the CAF calculation is the Required Capacity of the new generator, which is 5.0 MVA.

The RSN in this case is the existing 33kV feeder and the new 33kV feeder. The New Network Capacity is calculated using the non-secure capacity and is therefore the sum of the thermal capacities of the two feeders, which is 48.0 MVA. This is the denominator in the CAF calculation.

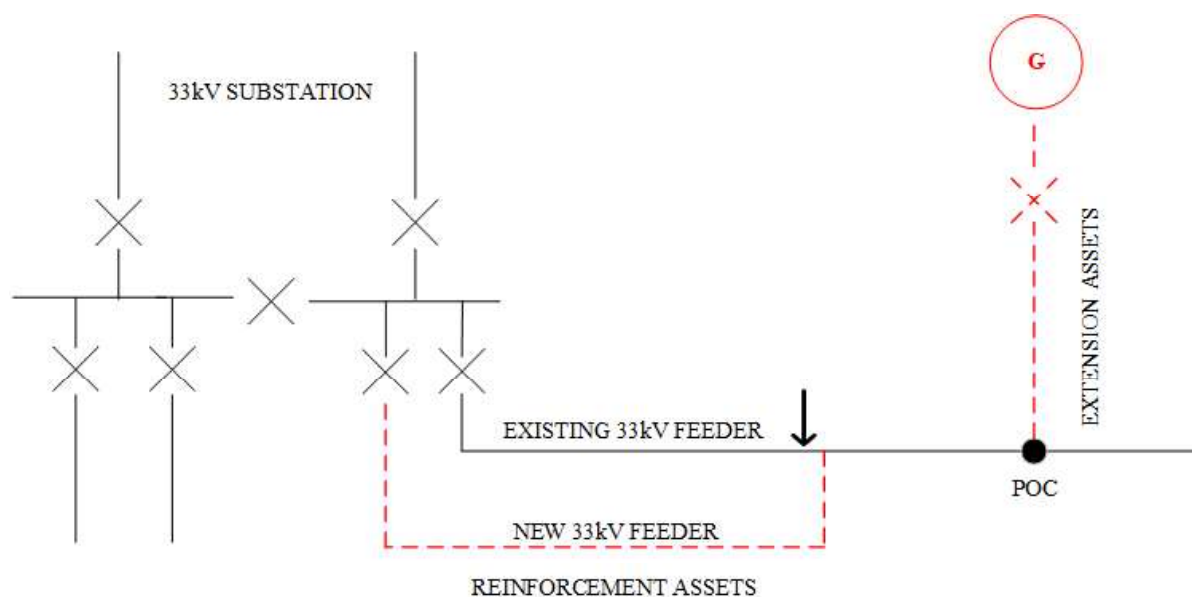

The Connection Charge for this Scheme is calculated as follows:

Reinforcement:

Reinforcement:	Cost	Apportionment	Customer Contribution
Installation of new 33kV feeder	£500,000	5.0 / 48.0 x 100% = 10.4%	£52,000
Total Reinforcement Cost	£500,000		£52,000

Extension Assets:	Cost	Apportionment	Customer Contribution
Installation of 1,000m 33kV cable	£400,000	n/a	£400,000
Installation of 33kV metering circuit breaker	£80,000	n/a	£80,000
11kV Jointing x2	£6,000	n/a	£6,000
Total Extension Asset Cost	£486,000		£486,000

Total cost of the work = £500,000 + £486,000 = **£986,000**

Total Connection Charge to Customer = £52,000 + £486,000 = **£538,000**

Example 24: A new non-secure Generation Connection with secure Reinforcement.

Purpose: To show the application of the apportionment rule where secure Reinforcement is provided but the connection for a Generation Connection is non-secure.

A Customer applies for a new generator (a Generation Connection) requiring an 8 MW metered connection. In this case, the Customer has exercised their option to request non-secure Extension Assets in the provision of the connection.

The existing network comprises a substation which has 2 x 15 MVA 33/11kV transformers. The Minimum Scheme to provide the connection is to install 750m of 11kV cable from the substation to the industrial premises, as Extension Assets. As there is insufficient capacity available from the existing 2 x 15 MVA transformers to provide the new connection, it will be necessary to upgrade the transformers to 2 x 24 MVA units along with their associated 11kV circuit breakers. The Reinforcement is required to ensure the 11kV network load can be maintained during planned or unplanned outages of one of the transformers. Although the Customer wishes to accept a non-secure connection, the substation must provide secure capacity to its Group Demand (which includes the Customer) to comply with the requirements of Engineering Recommendation P2. As the Extension Assets will be provided solely for the Customer, these can be provided on the basis of a single circuit to provide a non-secure connection, at the Customer's request.

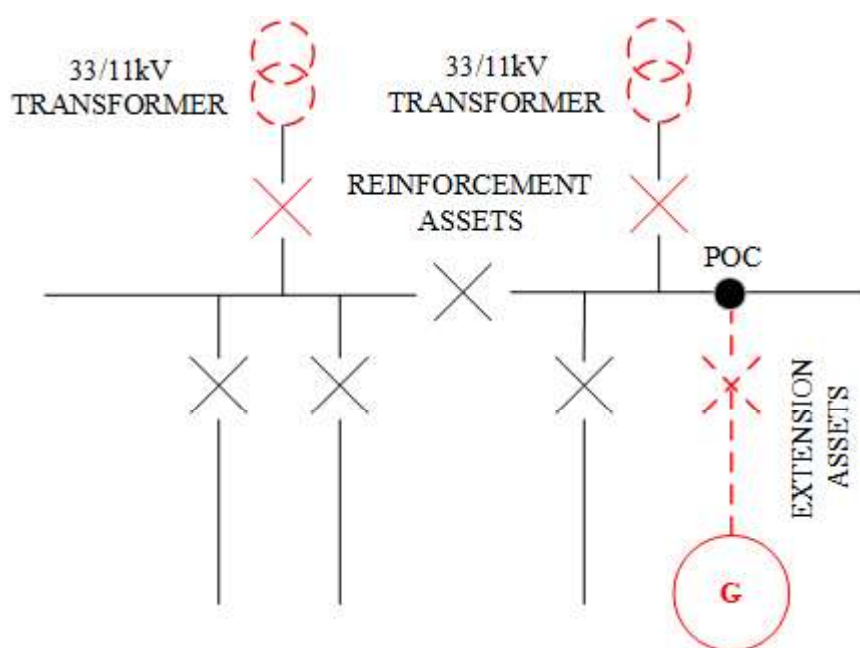
**Reinforcement:**

As the transformer Reinforcement is a voltage above, the generator will not contribute towards this part of the works.

The numerator in the CAF calculation is the Required Capacity, which is 8.0 MVA.

The New Network Capacity is the secure capacity of the transformers, which is 24 MVA. This is the denominator in the CAF calculation.

The Connection Charge for this Scheme is calculated as follows:

Reinforcement:	Cost	Apportionment	Customer Contribution
Installation of 2 x 24MVA 33/11kV transformers	£6,500,000	0%	£0
2 x 11kV circuit breakers	£60,000	8 / 24 x 100% = 33.3%	£20,000
Total Reinforcement Cost	£6,560,000		£20,000

Extension Assets:	Cost	Apportionment	Customer Contribution
750m 11kV cable	£225,000	n/a	£225,000
11kV metering circuit breaker	£30,000	n/a	£30,000
11kV joints x2	£6,000	n/a	£6,000
Total Extension Asset Cost	£261,000		£261,000

Total cost of the work = £6,560,000 + £261,000 = **£6,821,000**

Total Connection Charge to Customer = £20,000 + £261,000 = **£281,000**

Example 25: A new Generation Connection with voltage rise triggered Reinforcement.
Purpose: To show that a Generation Connection pays for Reinforcement at the voltage level of connection based on the CAF.

A Customer wishes to connect a new generator (a Generation Connection) with a Required Capacity for export purposes of 2MVA.

The local 11kV feeder has a large amount of generation already connected and will need to be reinforced in order to keep voltage rise within acceptable limits.

The Minimum Scheme requires Reinforcement of the existing 185mm² 11kV underground cable with 300mm² underground cable and installation of a new substation for connection of the 2MW export capacity. The total length of the reinforced cable is 2km. The thermal rating of the 300mm² underground cable is 8MVA. The 11kV underground cable on the other side of the normal open point is already 300mm² and does not require to be reinforced.

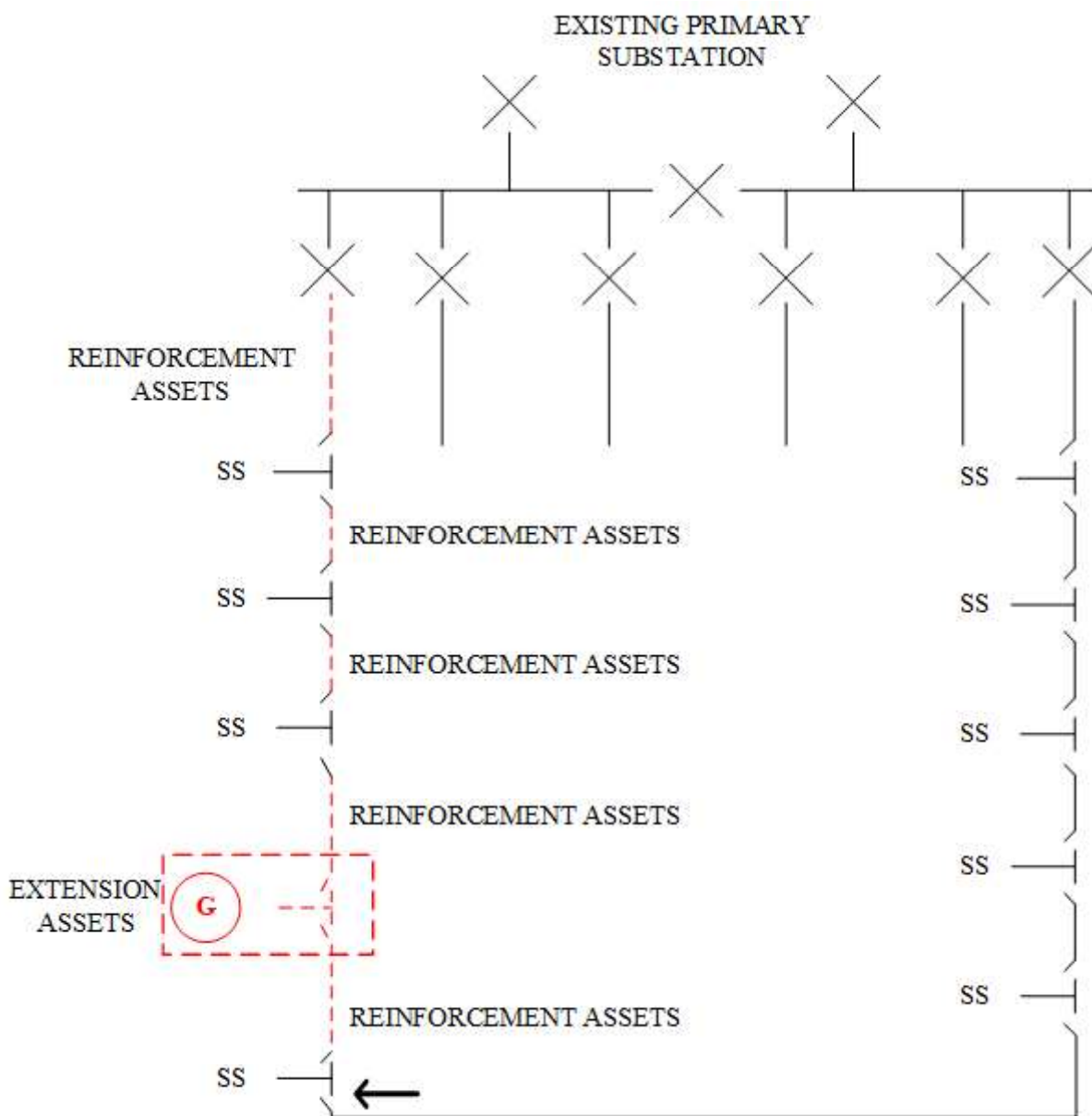

Reinforcement:

The Relevant Section of Network for the Reinforcement is the 11kV feeder.

Security CAF calculation: the numerator in the CAF calculation is the Required Capacity of the Customer, i.e. 2MW. The denominator is the New Network Capacity following Reinforcement, this being the maximum generation that could be connected whilst keeping the voltage rise within acceptable limits, i.e. 8MVA in this case.

Fault Level CAF calculation: this scheme does not have any significant Fault Level contribution to the existing shared use distribution network and Fault Level CAF is therefore not applicable here.

The Connection Charge for this Scheme is calculated as follows:

Reinforcement:	Cost	Apportionment	Customer Contribution
2km 300mm 11kV Cable	£600,000	$2 / 8 \times 100\% = 25\%$	£150,000
Total Reinforcement Cost	£600,000		£150,000

Extension Assets:	Cost	Apportionment	Customer Contribution
2MVA 11kV Substation	£160,000	n/a	£160,000
2 by 11kV Closing Joints	£6,000	n/a	£6,000
Total Extension Asset Cost	£166,000		£166,000

Total cost of the work = £600,000 + £166,000 = **£766,000**

Total Connection Charge to Customer = £150,000 + £166,000 = **£316,000**

Example 26 A new Generation Connection with voltage rise triggered Reinforcement.

Purpose: To show that if voltage rise Reinforcement is tailored so that just the amount of network is upgraded to meet the Customer requirements, the CAF is 100% for a Generation Connection.

A Customer wishes to connect a new generator (a Generation Connection) with a Required Capacity for export of 250kW. The Minimum Scheme for connection of the generator requires the local 11kV overhead line to be reinforced with 100mm² conductor over part of its length in order to keep voltage rise within acceptable limits. The thermal capacity of the 100mm² overhead line is 5MVA. The thermal capacity of the original 50mm² overhead line is 3MVA. A new 315kVA ground mounted substation requires to be installed at the premises. The overhead line is 1km in length but only 500m is required to be reinforced in order to keep voltage rise within acceptable limits.

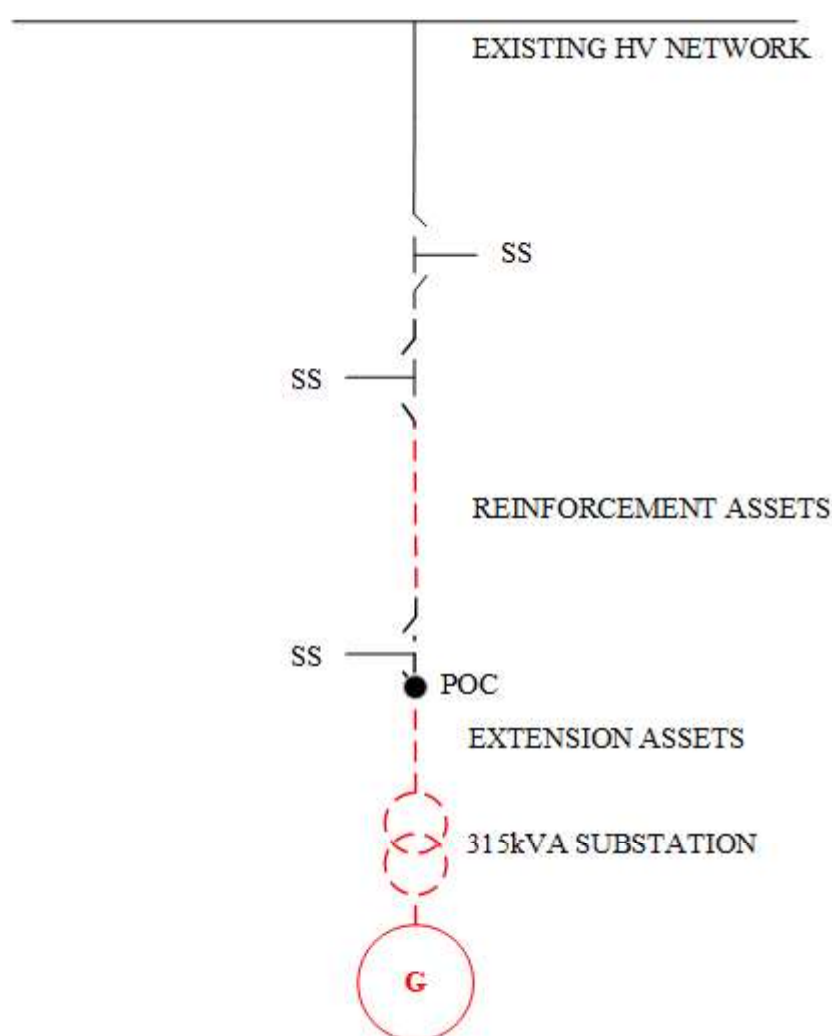

Reinforcement:

The Relevant Section of Network for the Reinforcement is the 11kV overhead line

Security CAF calculation: the numerator in the CAF calculation is the Required Capacity of the Customer, i.e. 250kW. The denominator is the New Network Capacity following Reinforcement, this being the maximum generation that could be connected whilst keeping the voltage rise within acceptable limits. As the length of overhead line to be reinforced has been determined to accommodate the 250kW requirement only, then this is also 250kW in this case.

Fault Level CAF calculation: this scheme does not have any significant Fault Level contribution to the existing shared use distribution network and Fault Level CAF is therefore not applicable here.

The Connection Charge for this Scheme is calculated as follows:

Reinforcement:	Cost	Apportionment	Customer Contribution
Replacement 11kV overhead line conductor	£40,000	250 / 250 x 100% = 100%	£40,000
Total Reinforcement Cost	£40,000		£40,000

Extension Assets:	Cost	Apportionment	Customer Contribution
Provision and installation of 315kV substation	£60,000	n/a	£60,000
11kV joint to network	£3,000	n/a	£3,000
Total Extension Asset Cost	£63,000		£63,000

Total cost of the work = £40,000 + £63,000 = **£103,000**

Total Connection Charge to Customer = £40,000 + £63,000 = **£103,000**

The Connection Charge for this Scheme is calculated as follows:

Transmission Works:	Cost	Apportionment	Customer Contribution
Replace the 132kV transformer tails and associated switchgear	£5,000,000	N/A	£5,000,000
Total Transmission Cost	£5,000,000		£5,000,000

Reinforcement:	Cost	Apportionment	Customer Contribution
Reinforcement: replace the existing 132kV switchgear	£10,000,000	$3 \times (85/9140) \times 100\% = 2.8\%$	£280,000
Total Reinforcement Cost	£10,000,000		£280,000

Extension Assets:	Cost	Apportionment	Customer Contribution
Installation of 200m 132kV underground cable	£400,000	N/A	£400,000
Total Extension Asset Cost	£400,000		£400,000

Total cost of the work = £5,000,000 + £10,000,000 + £400,000 = **£15,400,000**

Total Connection Charge to Customer = £5,000,000 + £280,000 + £400,000 = **£5,680,000**

This same principle would apply in Scotland where there is no 132kV Distribution System and the connection Customer would pay for any transmission works they trigger.

Example 28: A new Generation Connection with Fault Level Triggered Reinforcement and transmission works.

Purpose: To show the treatment of Reinforcement costs at more than one voltage level above the POC and the cost of transmission works for a Generation Connection.

A Customer requests a 50MW connection for a new 33kV generator (a Generation Connection) and the 75MVA Fault Level contribution from the generator necessitates Reinforcement works to replace the 132kV switchgear at the existing grid supply point with switchgear of a higher fault level rating. The Fault Level contribution also requires upgrades to the transmission system to replace the 132kV transformer tails and associated switchgear. New 33kV Extension Assets from the existing 33kV system will be required to connect the generator.

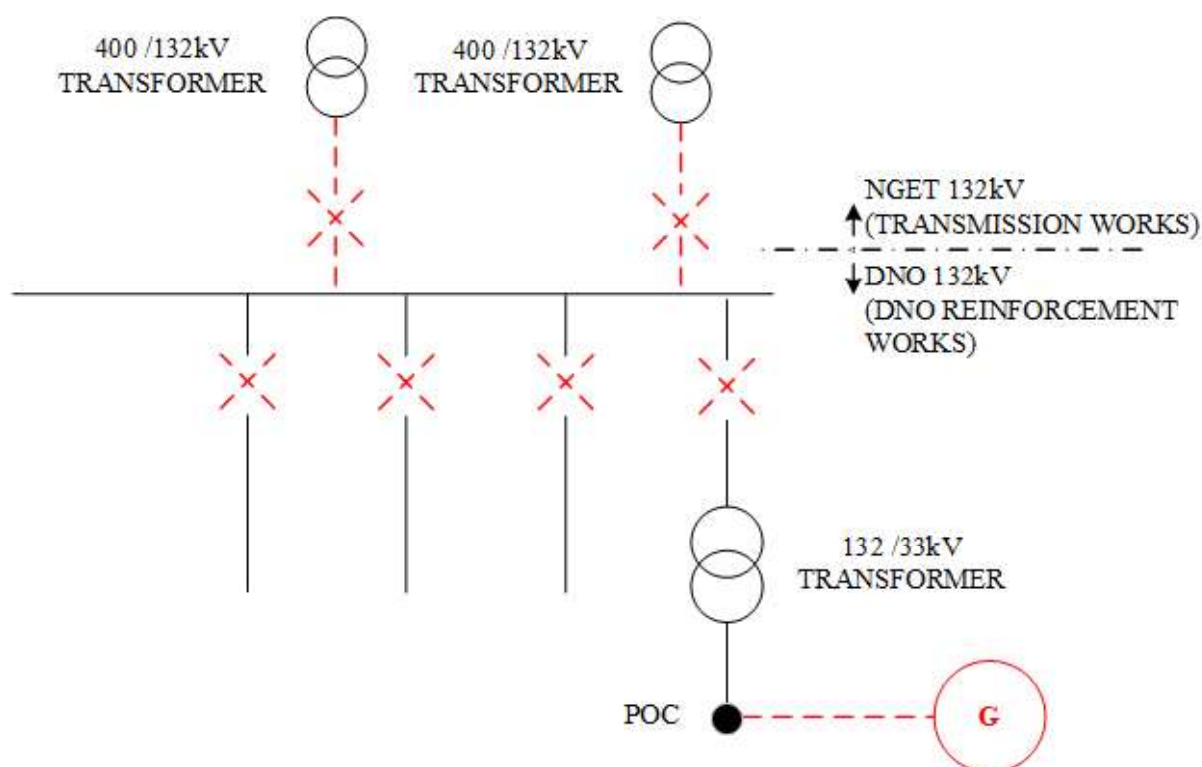

Reinforcement

In this example the Reinforcement is at the voltage level above the POC and fully funded by the DNO.

Transmission

The Connection Charge for this Scheme is calculated as follows:

Transmission Works:	Cost	Apportionment	Customer Contribution
Replace the 132kV transformer tails and associated switchgear	£5,000,000	N/A	£5,000,000
Total Transmission Cost	£5,000,000		£5,000,000

Reinforcement:	Cost	Apportionment	Customer Contribution
Replacement 132kV switchboard (excluding Customer's sole use circuit breaker)	£10,000,000	N/A	£0
Total Reinforcement Cost	£10,000,000		£0

Extension Assets:	Cost	Apportionment	Customer Contribution
Installation of a 500m 33kV cable	£40,000	N/A	£40,000
33kV circuit breaker at Customer substation	£25,000	N/A	£25,000
Total Extension Asset Cost	£75,000		£75,000

Total cost of the work = £5,000,000 + £10,000,000 + £75,000 = **£15,075,000**

Total Connection Charge to Customer = £5,000,000 + £75,000 = **£5,075,000**

This same principle would apply in Scotland where there is no 132kV Distribution System and the connection Customer would pay for any transmission works they trigger.

Example 29: A new Demand Connection that has Reinforcement above the High-Cost Project Threshold.

Purpose: To show how the Demand High-Cost Project Threshold is applied.

A Customer wishes to connect a new supply to a commercial premise for 70kVA (the Required Capacity). This will be a non-secure Demand Connection to a secure network.

The Minimum Scheme is to overlay part of the nearest 11kV circuit (Feeder 2) which only has spare capacity of 50kVA. The Reinforcement to make the capacity available requires 1200m of existing 11kV cable to be overlaid with a larger capacity cable.

Following the Reinforcement the New Network Capacity will be 8000kVA. (i.e. after Reinforcement, in this particular case, the section of cable with the lowest rating in the ring represented by Feeder 1 and Feeder 2 is rated at 8000kVA).

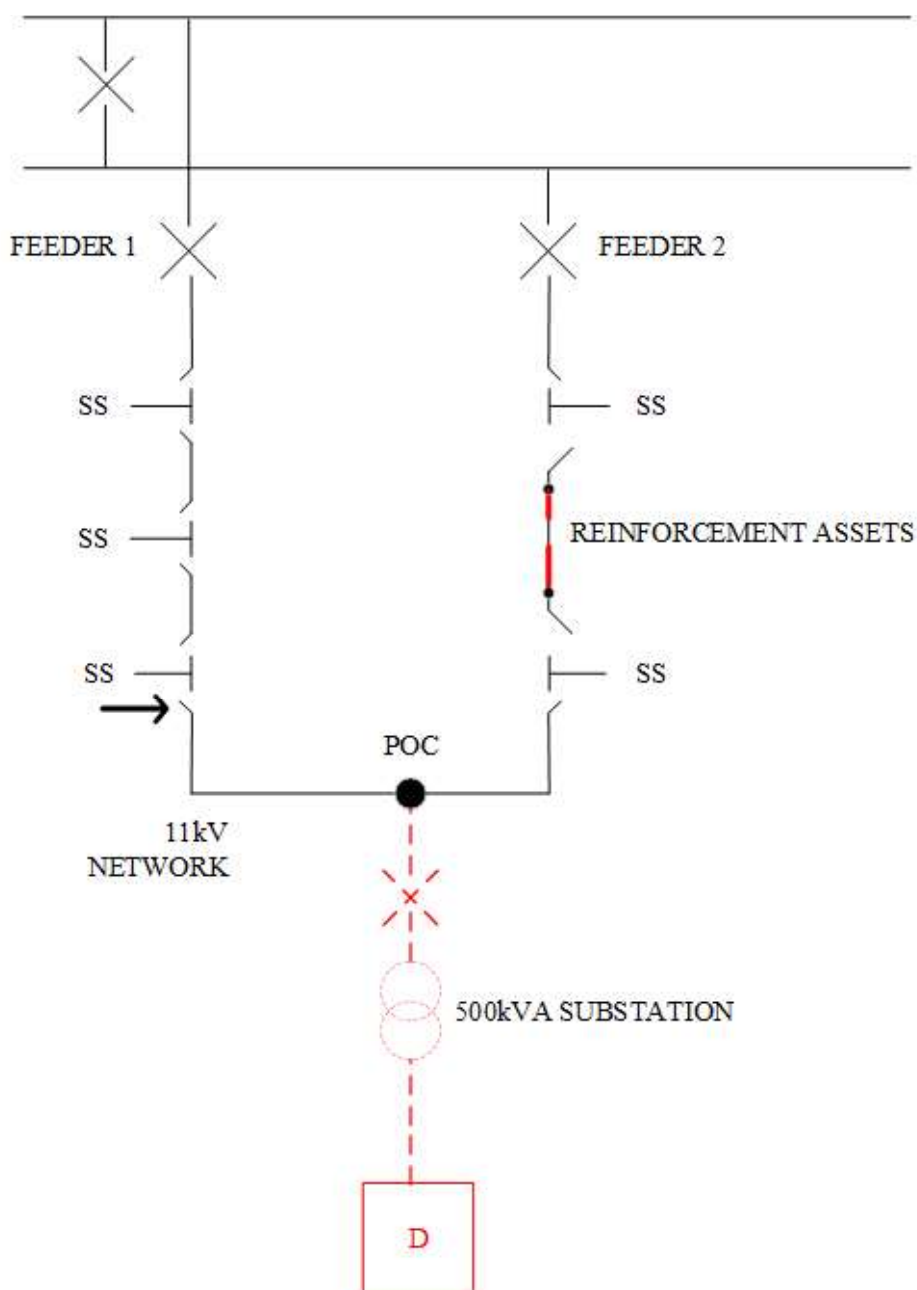

Reinforcement:

The Relevant Section of Network is the two-feeder ring comprising Feeder 1 and Feeder 2.

As this is a Demand Connection, no CAF contribution is required.

The High-Cost Project Threshold (HCPT) applied is the Required Capacity x HCPT of £1,720 per kVA.

In this instance;

$70 \times £1,720 = £120,400$. The Customer will pay the costs in excess of £120,400 for works up to one voltage above the Point of Connection, therefore £363,000 (i.e, total Reinforcement cost - £120,400 = £242,600).

The Connection Charge for this Scheme is calculated as follows:

Reinforcement:	Cost	Apportionment	Customer Contribution
Overlay 1200m of 11kV cable	£360,000	Total cost exceeding HCPT £363,000- £120,400	£242,600
11kV Jointing	£3,000		
Total Reinforcement Cost	£363,000		£242,600

Extension Assets:	Cost	Apportionment	Customer Contribution
500m 11kV cable	£150,000	n/a	£150,000
500kVA substation	£70,000	n/a	£70,000
Termination of Customer's LV cable	£2,000	n/a	£2,000
LV Metering panel	£4,000	n/a	£4,000
11kV Jointing x2	£6,000	n/a	£6,000
Total Extension Asset Cost	£232,000		£232,000

Total cost of the work = £363,000 + £232,000 = **£595,000**

Total Connection Charge to Customer = £242,600 + £232,000 = **£474,600**

Example 30: A new Generation Connection that has Reinforcement above the High-Cost Project Threshold.

Purpose: To show how a Generation Connection that triggers the Generation High-Cost Project Threshold is charged when the Reinforcement required is at the same voltage of connection.

A Customer wishes to connect a 225kVA wind farm (a Generation Connection).

In order to connect the wind farm the Minimum Scheme involves the installation of 590m of 11kV overhead line, 350m of 11kV cable and associated jointing and install switchgear into the substation. In addition, Reinforcement is required to replace the 33/11kV transformer to facilitate reverse power flow and the 11kV circuit breaker in the primary substation. The New Network Capacity following Reinforcement is 19,700 kVA. The total cost of the Reinforcement is £505,400.

The High-Cost Project Threshold (HCPT) applies to this connection. The HCPT is £200/kW and costs in excess of this threshold will be charged in full to the Customer.

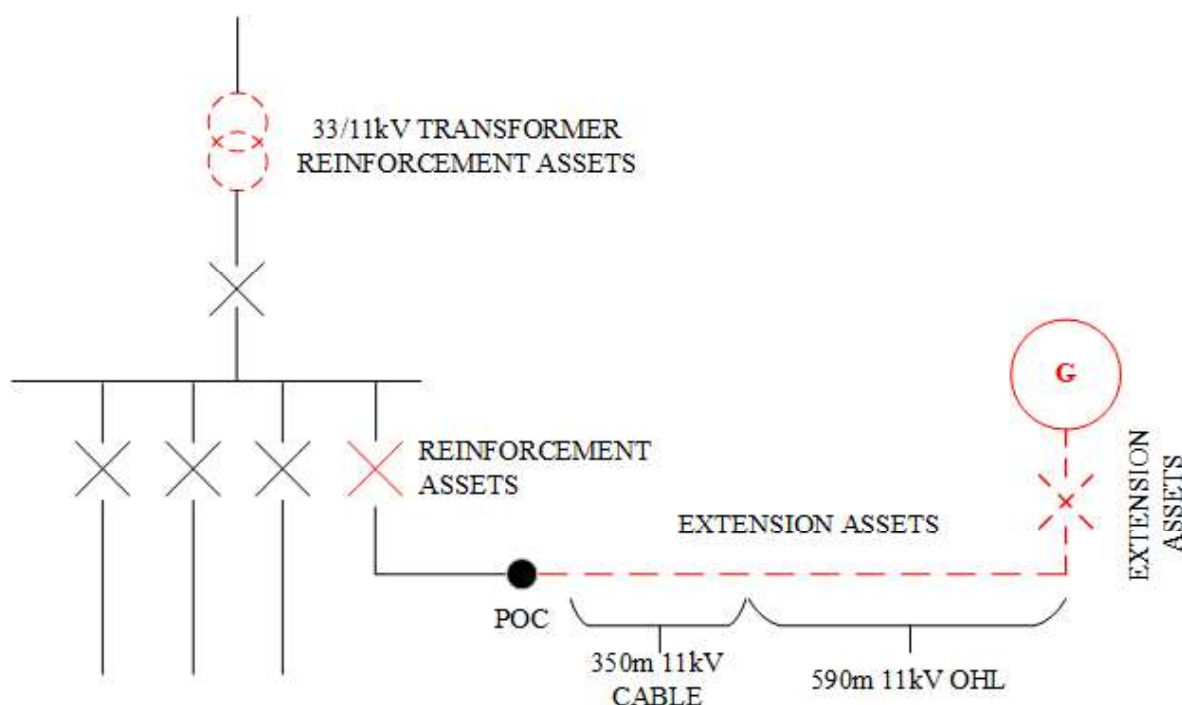

Reinforcement:

Security CAF calculation: the numerator in the CAF calculation is the Required Capacity of the Customer, i.e. 225kVA. The denominator is the New Network Capacity following Reinforcement, this being the maximum generation that could be connected whilst keeping the voltage rise within acceptable limits. This is 19,700kVA.

The High-Cost Project Threshold for Generation Connections is £200/kW.

The Reinforcement required to provide the connection is:

- 33/11kV transformer; and
- 11kV circuit breaker.

The 33/11kV transformer Reinforcement is one Voltage Level above the POC and not subject to the Security CAF. The work is covered by the High-Cost Project Threshold of £200/kW.

HCPT: £200 x 225 = £45,000

£505,400 - £45,000 = £460,400 Customer Contribution

The 11kV circuit breaker Reinforcement of £30,000 is at the Voltage Level of the POC and is subject to the Security CAF. The work is under the High-Cost Project Threshold of £45,000 (£200 x 225) and not covered.

Security CAF: $(225/19,700) \times 100 = 1.14\%$

£30,000 x 1.14% = £342 Customer Contribution

The Connection Charge for this Scheme is calculated as follows:

Reinforcement Over High-Cost Project Threshold:	Cost	Apportionment/ HCPT	Customer Contribution
33/11kV Transformer Replacement	£475,400	£505,400- £45,000= £460,400	£460,400
11kV circuit breaker	£30,000		
Total Reinforcement Cost	£505,400		£460,400

Reinforcement Under High-Cost Project Threshold:	Cost	Apportionment/ HCPT	Customer Contribution
11kV circuit breaker	£30,000	$225/19,700 =$ 1.14%	£342
Total Reinforcement Cost	£30,000		£342

Extension Assets:	Cost	Apportionment	Customer Contribution
Electrical substation works	£34,500	n/a	£34,500
Install 590m of 11kV Overhead Line	£53,500	n/a	£53,500
Install 350m of 11kV XLPE cable	£14,000	n/a	£14,000
Total Extension Asset Cost	£102,000		£102,000

Total cost of the work = £505,400 + £102,000 = **£607,400**

Total Connection Charge to Customer = £460,400 + £342 + £102,000 = **£562,742**

Example 31 The Customer requirements for supply characteristics are greater than the Minimum Scheme.

Purpose: To illustrate that when a Customer specifically requests a three-phase connection, where the existing network is not of a sufficient number of phases, the Customer pays for any Reinforcement.

A Customer with an existing single phase domestic connection with rated at 100 Amps (23 kVA) requests a three-phase connection to allow them to connect a three-phase load (e.g. a three-phase domestic welder). The property is located halfway along on a single phase 100m LV overhead line, which connects to a single phase 50kVA pole-top transformer feeding four properties. The pole-top transformer connects to the local Primary substation via a three-phase underground cable.

The existing network has sufficient capacity to accommodate the Required Capacity but the existing 50kVA pole-top transformer and 100m LV overhead line do not have a sufficient number of phases.

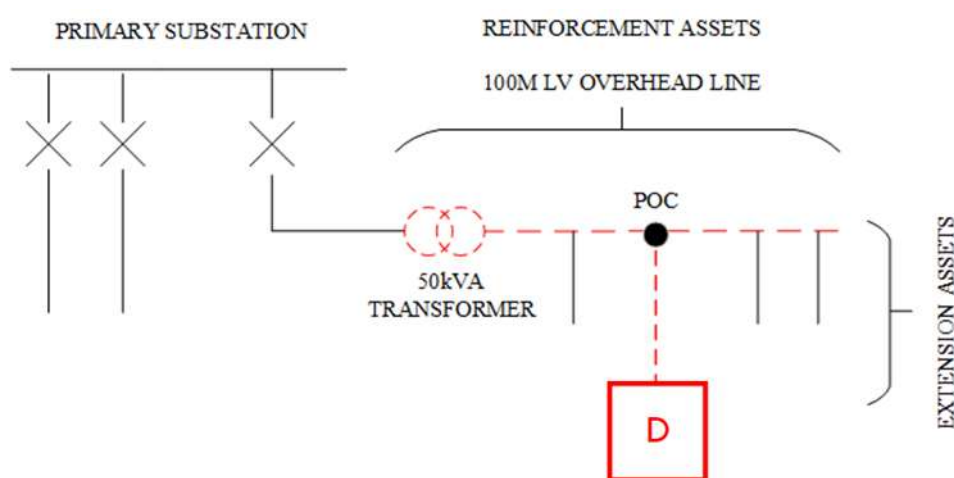

Reinforcement:

The Minimum Scheme is to replace the existing 100m LV overhead line in its entirety with a three-phase overhead line. The existing single phase 50kVA pole-top transformer will need to be replaced with a three-phase equivalent. The existing three-phase cable feed and the Primary substation are of sufficient capacity.

As the Reinforcement is only to accommodate the required number of phases, no cost apportionment will be applied.

The Connection Charge for this Scheme is calculated as follows:

Reinforcement:	Cost	Apportionment	Customer Contribution
Replace existing single-phase LV Overhead Line with new 100m three-phase LV Overhead Line	£12,600	100%	£12,600
New three-phase 50kVA pole-top transformer	£20,000	100%	£20,000
LV Jointing	£300	100%	£300
Total Reinforcement Cost	£32,900		£32,900
Operation & Maintenance @32%* of £32,900	£10,528		£10,528

*Note, the 32% Operation and Maintenance figure is illustrative.

Extension Assets:	Cost	Apportionment	Customer Contribution
New 30m three-phase 100A service	£1,600	n/a	£1,600
Single service breach joint	£300	n/a	£300
Total Extension Asset Cost	£1,900		£1,900

Total cost of the work = £43,428 + £1,900 = **£45,328**

Total Connection Charge to Customer = £43,428 + £1,900 = **£45,328**

Example 32: A new Generation Connection that has Reinforcement costs above the High-Cost Project Threshold at the Voltage Level of the POC (single asset to be cost apportioned).

Purpose: To show how a Generation Connection that triggers the Generation High-Cost Project Threshold at the Voltage Level of the POC is charged when the Reinforcement required is for a single asset at the same Voltage Level of connection.

As in Example 30, a Customer wishes to connect a 225kW wind farm (a Generation Connection).

To connect the wind farm, the Minimum Scheme involves the installation of 590m of 11kV overhead line, 350m of 11kV cable and associated jointing and install switchgear into the substation. In addition, Reinforcement is required to replace the 33/11kV transformer to facilitate reverse power flow and the 11kV circuit breaker in the primary substation. The New Network Capacity following Reinforcement is 19,700 kVA. The total cost of the Reinforcement is £525,400.

The High-Cost Project Threshold is exceeded for this connection. The HCPT is £200/kW (£45,000) and costs in excess of this threshold will be charged in full to the Customer (£480,400).

The cost of Reinforcement at the Voltage Level of the POC (£50,000) exceeds the High-Cost Project Threshold. The cost of Reinforcement to be apportioned at the Voltage Level of the POC is therefore scaled down by the amount over the High-Cost Project Threshold at that Voltage Level.

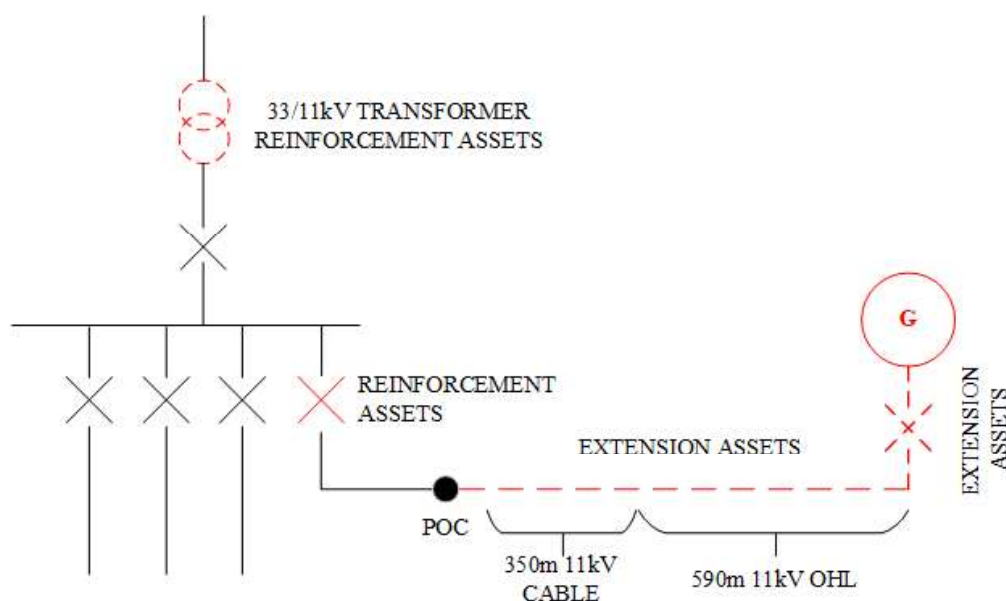

Reinforcement:

Security CAF calculation: the numerator in the CAF calculation is the Required Capacity of the Customer, i.e. 225kW. The denominator is the New Network Capacity following Reinforcement, this being the maximum generation that could be connected whilst keeping the voltage rise within acceptable limits. This is 19,700kVA.

The High-Cost Project Threshold for a Generation Connection is £200/kW.

The Reinforcement required to provide the connection is:

- 33/11kV transformer; and
- 11kV circuit breaker.

The 33/11kV transformer Reinforcement is one Voltage Level above the POC and not subject to the Security CAF. The work is covered by the High-Cost Project Threshold of £200/kW.

$$\text{HCPT: } £200 \times 225 = £45,000$$

$$£525,400 - £45,000 = £480,400 \text{ Customer Contribution}$$

The 11kV circuit breaker Reinforcement of £50,000 is at the Voltage Level of the POC and is subject to the Security CAF, however, the cost of the work is over the High-Cost Project Threshold of £45,000. To avoid any double charging, the Reinforcement cost at the Voltage Level of the POC is scaled down using the formula below.

The cost to be apportioned for the 11kV circuit breaker is therefore:

$$\begin{aligned} & \text{Reinforcement cost} \times \frac{\text{High-Cost Project Threshold}}{\text{Total Reinforcement cost at the Voltage Level of the POC}} \\ & £50,000 \times \frac{£45,000}{£50,000} \\ & = £45,000 \end{aligned}$$

$$\text{Security CAF: } (225/19,700) \times 100 = 1.14\%$$

$$£45,000 \times 1.14\% = £513 \text{ Customer Contribution}$$

The Connection Charge for this Scheme is calculated as follows:

Reinforcement Over High-Cost Project Threshold:	Cost	Apportionment/ HCPT	Customer Contribution
33/11kV Transformer Replacement	£475,400	£525,400- £45,000= £480,400	£480,400
11kV circuit breaker	£50,000		
Total Reinforcement Cost	£525,400		£480,400

Reinforcement Under High-Cost Project Threshold:	Cost	Apportionment/ HCPT	Customer Contribution
11kV circuit breaker	£45,000 (£50,000 x (£45,000 / £50,000))	225/19,700 = 1.14%	£513
Total Reinforcement Cost (to be apportioned)	£45,000		£513

Extension Assets:	Cost	Apportionment	Customer Contribution
Electrical substation works	£34,500	n/a	£34,500
Install 590m of 11kV Overhead Line	£53,500	n/a	£53,500
Install 350m of 11kV XLPE cable	£14,000	n/a	£14,000
Total Extension Asset Cost	£102,000		£102,000

Total cost of the work = £525,400 + £102,000 = **£627,400**

Total Connection Charge to Customer = £480,400 + £513 + £102,000 = **£582,913**

Example 33 A new Generation Connection that has Reinforcement costs above the High-Cost Project Threshold at the Voltage Level of the POC (multiple assets to be cost apportioned).

Purpose: To show how a Generation Connection that triggers the Generation High-Cost Project Threshold at the Voltage Level of the POC is charged when the Reinforcement required is for multiple assets at the same Voltage Level of connection.

Like Example 13, a Customer requests a connection to a generator with a Required Capacity for export purposes of 3MW (6MW in Example 13). The Fault Level contribution at the primary substation from the generation connection is 10MVA.

The POC is to the existing 11kV network at point B and it is proposed to install 500m of 11kV underground cable from the POC to the Customer's installation. This is treated as Extension Assets.

The connection requires the Reinforcement of 500m of 11kV overhead line between points A and B for a thermal capacity requirement and the Security CAF applies. The connection also requires the replacement of the existing 11kV switchboard at the primary substation in order to increase its fault level rating from 150MVA to 350MVA and the Fault Level CAF applies. However, the new fault level will be limited by the fault level rating of the local network of 250MVA. The total cost of the Reinforcement is £820,000.

The High-Cost Project Threshold is exceeded for this connection. The HCPT is £200/kW (£600,000) and costs in excess of this threshold will be charged in full to the Customer (£220,000). The cost of Reinforcement all relates to the Voltage Level of the POC. The cost of Reinforcement to be apportioned at the Voltage Level of the POC is therefore scaled down by the amount over the High-Cost Project Threshold at that Voltage Level.

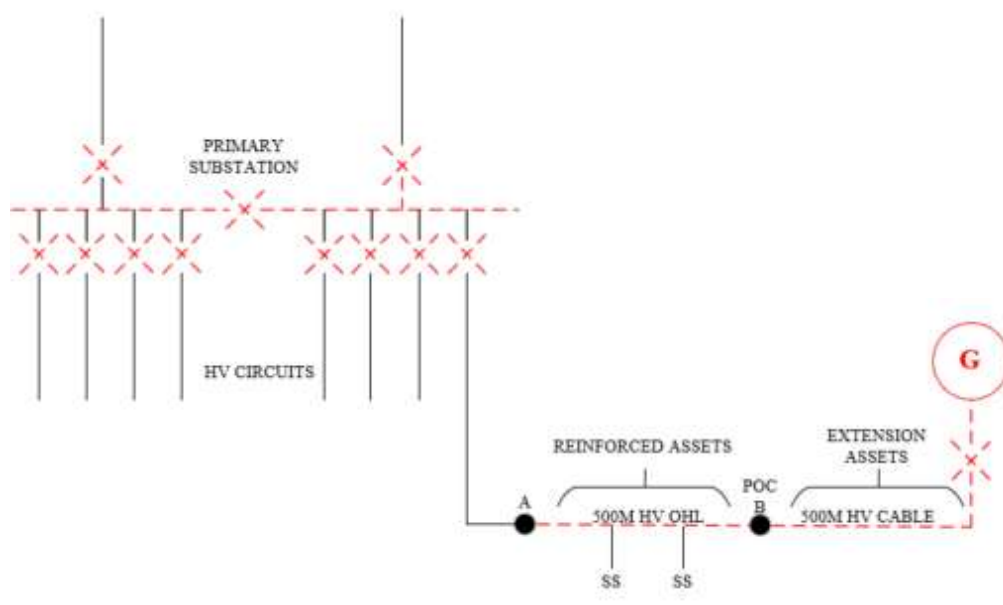

Reinforcement:

The Relevant Section of Network is the 11kV network from the primary substation to Point B.

Security CAF calculation: the numerator in the CAF calculation is based upon the Required Capacity of the Customer, i.e. 3MW. The denominator is based on the New Network Capacity following

Reinforcement, which is 7.6MVA, i.e. after Reinforcement, in this particular case, the section of cable with the lowest rating.

The Relevant Section of Network is the 11kV switchboard at the primary substation.

Fault Level CAF calculation: The numerator in the CAF calculation is based upon the Fault Level contribution from the Customer's new generator connection, in this Example 10MVA. The denominator is based upon the New Fault Level Capacity, which is the lower of the Fault Level capacity of the new 11kV switchboard, 350MVA or of the local system, 250MVA in this Example.

The High-Cost Project Threshold for a Generation Connection is £200/kW.

The Reinforcement required to provide the connection (£820,000) is:

- Re-conductor of 500m of 11kV overhead line (£20,000); and
- Replacement 11kV switchboard (£800,000).

HCPT: £200 x 3,000 = £600,000

£820,000 - £600,000 = £220,000 Customer Contribution

The Reinforcement of £820,000 is at the Voltage Level of the POC and is subject to both the Security CAF and Fault Level CAF, however, the aggregate cost of the work is over the High-Cost Project Threshold of £600,000. To avoid any double charging, the Reinforcement costs at the Voltage Level of the POC are scaled down using the formula below.

The cost of Reinforcement to be apportioned for the re-conductor of 500m of 11kV overhead line is:

$$\begin{aligned} & \text{Reinforcement cost} \times \frac{\text{High-Cost Project Threshold}}{\text{Total Reinforcement cost at the Voltage Level of the POC}} \\ & £20,000 \times \frac{£600,000}{£820,000} \\ & = £14,634 \end{aligned}$$

Security CAF: $(3,000/7,600) \times 100 = 39.47\%$

£14,634 x 39.47% = £5,776 Customer Contribution

The cost of Reinforcement to be apportioned for the replacement 11kV switchboard is:

$$\begin{aligned} & \text{Reinforcement cost} \times \frac{\text{High-Cost Project Threshold}}{\text{Total Reinforcement cost at the Voltage Level of the POC}} \\ & £800,000 \times \frac{£600,000}{£820,000} \\ & = £585,366 \end{aligned}$$

Fault Level CAF: $3 \times (10/250) \times 100 = 12.00\%$

£585,366 x 12.00% = £70,244 Customer Contribution

The Connection Charge for this Scheme is calculated as follows:

Reinforcement Over High-Cost Project Threshold:	Cost	Apportionment/ HCPT	Customer Contribution
Re-conductor of 500m of 11kV overhead line	£20,000	£820,000- £600,000= £220,000	£220,000
Replacement 11kV switchboard	£800,000		
Total Reinforcement Cost	£820,000		£220,000

Reinforcement	Cost	Apportionment	Customer Contribution
Re-conductor of 500m of 11kV overhead line	£14,634 (£20,000 x £600,000 / £820,000)	3/7.6 x 100% = 39.47% Security CAF	£5,776
Replacement 11kV switchboard	£585,366 (£800,000 x £600,000 / £820,000)	3x (10/250) x 100% = 12.0% Fault Level CAF	£70,244
Total Reinforcement Cost (to be apportioned)	£800,000		£76,020

Extension Assets	Cost	Apportionment	Customer Contribution
Installation of 500m 11kV cable	£150,000	n/a	£150,000
11kV circuit breaker at Customer's substation	£12,000	n/a	£12,000
11kV pole top termination	£2,500	n/a	£2,500
Total Extension Asset Cost	£164,500		£164,500

Total cost of the work: = £820,000 + £164,500 = **£984,500**

Total Connection Charge to Customer = £220,000 + £76,020 + £164,500 = **£460,520**

Section 2 – Glossary of Terms

Act	the Electricity Act 1989 (as amended).
Adoption Agreement	<p>is an agreement for us to adopt the Contestable Work, subject to the satisfaction of certain conditions. This agreement, amongst other things, addresses a number of fundamental principles:</p> <ul style="list-style-type: none"> • The transfer of title from the asset owner (normally the Customer or the ICP) to us; • The quality and safety of the adopted asset; • Any required sureties; • The transfer of Land Rights; • The procedure for us to Energise the assets installed by the ICP during the works; • The payment of any residual Connection Charges or fees; • Planning permissions and compliance with street works legislation; and • Defect correction processes, where applicable. <p>The parties to the Adoption Agreement may vary depending on the circumstances and may be between:-</p> <ul style="list-style-type: none"> • us and you • us and your appointed ICP • us, you and your appointed ICP.
Bilateral Connection Agreement	an agreement between us and another LDNO setting out the terms and conditions under which an embedded network shall be entitled to be and remain connected to the Distribution System.
Business Day	any day other than a Saturday, a Sunday, Christmas Day, Good Friday or a day which is a bank holiday within the

	meaning of the Banking and Financial Dealings Act 1971 and will be from 9:00am to 5:00pm (GMT or BST as applicable).
CIC Charges	are the charges detailed in parts D, E, G, H, I, and J of Section [7] of this document.
Connection Agreement	<p>the owner/ occupier of the Premises to which the connection is to be provided will be required to enter into a Connection Agreement with us. The Connection Agreement will set out the terms upon which they will be, and remain, connected to our Distribution System. The Connection Agreement will normally be provided on our behalf by the owner/occupier's chosen Supplier for the Premises as part of their application for a supply of electricity.</p> <p>However, in some cases for larger connections, or where non-standard conditions exist, we will provide a site-specific Connection Agreement, which replaces any Connection Agreement put in place via the Supplier, as part of the connection process. This particular Connection Agreement will only take effect upon completion of the connection and will set out, in more detail, our rights and obligations to one another. Additionally, it may contain the technical detail of the installation being connected to the Distribution System and will require the owner/occupier of the Premises to comply with the provisions of the Distribution Code.</p>
Connection Charge	the payment to be made by the applicant to us for the provision of the connection.
Curtailed Connection	means a connection whereby the Required Capacity can be restricted by the Company in accordance with DCUSA Schedule 2D.

CUSC	the Connection and Use of System Code which constitutes the contractual framework for connection to, and use of, the GB Transmission System.
Customer	the person requesting the connection.
DCUSA	the Distribution Connection and Use of System Agreement designated as such by the Authority under condition 22 of the Licence.
Dedicated Scheme	is defined in paragraph 1.40.
De-energise	to deliberately prevent the flow of electricity to or from an Exit/ Entry Point for any purpose other than a system outage on the our Distribution System (and cognate expressions shall be construed accordingly).
Demand Connection	a connection which is not a Generation Connection.
Development Phase	the five year period, unless otherwise agreed with us, commencing on the date of Energisation of an embedded network during which period the development is to be constructed.
Disconnect	means to permanently De-energise an Exit/ Entry Point by the removal of all or part of our equipment (and cognate expressions shall be construed accordingly).
Distributed Generation Connections Guide	the guide produced by us as required by our Licence which provides guidance on the connection process for distributed generation.
Distribution Code	covers, amongst other matters, all material technical aspects relating to: <ul style="list-style-type: none"> • connection to, and the operation and use of, the Distribution System; and

	<ul style="list-style-type: none"> the operation of electrical lines and electrical plant or apparatus connected to the Distribution System. <p>A copy of the Distribution Code can be downloaded from the Distribution Code website at www.dcode.org.uk.</p>
Distribution System	the system (as defined in the Licence) consisting (wholly or mainly) of electric lines owned or operated by us and used for the distribution of electricity.
ECCR	the Electricity (Connection Charges) Regulations 2017 (SI 2017/106) as amended from time to time.
ECCR Prescribed Period	the relevant period from the date on which a connection is made as prescribed by the ECCR, being ten years, for connections made on or after 6 April 2017.
EHV	more than 22kV but not more than 72kV.
Electric Lines	<p>means any line which is used for carrying electricity to or from an Exit/ Entry Point and includes, unless the context otherwise requires:</p> <ul style="list-style-type: none"> (a) any support for such line, that is to say, any structure, pole or other thing in, on, by or from which any such line is or may be supported, carried or suspended; (b) any apparatus connected to such line for the purpose of carrying electricity; and (c) any wire, cable, tube, pipe or other similar thing (including its casing or coating) which surrounds or supports, or is surrounded or supported by, or is installed in close proximity to, or is supported, carried or suspended in association with, any such line.
Electric Plant	means any plant, equipment, apparatus or appliance used for or for purposes connected with the distribution of electricity

	(including any metering equipment) other than an Electric Line.
Electricity Storage	is the conversion of electrical energy into a form of energy which can be stored, the storing of that energy, and the subsequent reconversion of that energy back into electrical energy.
Electricity Generation	is the process of generating electricity.
Energise	to deliberately allow the flow of electricity to or from an Exit/ Entry Point where such a flow of electricity has never previously existed (and cognate expressions shall be construed accordingly).
Enhanced Scheme	is defined in paragraph 1.4.
Entry/ Exit Point	a point at which electricity, whether metered or unmetered, enter or exit our Distribution System.
ESO Licence	means a licence granted or treated as granted under section 6(1)(da) of the Act.
Existing Capacity	is defined in paragraph 1.29.
Extension Assets	are assets installed to connect a party or parties to the existing distribution network but which exclude Reinforcement assets.
Fault Level	the maximum prospective current or power that will flow into a short circuit at a point on the network, usually expressed in MVA or kA.
Fault Level Contribution from Connection	is defined in paragraph 1.29.
Flexible Connections	are connection arrangements whereby a Customer's export or import of electricity is managed (often through real-time control) based upon contracted and agreed principles of

	available capacity. Flexible Connections typically allow quicker and cheaper connection to the Distribution System but are made on the basis that there is no limit on the extent to which a user's access can be interrupted.
Full Planning Permission	an approval in writing by the relevant planning authority of all of the details of a proposed development such that the proposed development may proceed in accordance with that approval.
GB Transmission System	the system consisting (wholly or mainly) of high voltage electric wires owned or operated by transmission licensees and/or the ISOP as the holder of the ESO Licence within Great Britain.
Generation Connection	means a connection to a Premises where the primary purpose of the Premises is wholly or mainly Electricity Generation and/or Electricity Storage. In determining such primary purpose we will consider: <ul style="list-style-type: none"> i. if the Maximum Capacity of the connection of the Premises to the Distribution System for export is greater than the Maximum Capacity for import; ii. if the Premises has a Generation Licence; iii. if the Premises has a Generation Licence Exemption; and/or iv. any other information we consider relevant.
Generation Licence	means the owner or occupier of the Premises holds a licence to carry out the activity specified in section 4(1)(a) of the Act.
Generation Licence Exemption	means the owner or occupier of the Premises has an exemption from holding a Generation Licence, including

	under the Electricity (Class Exemptions from the Requirement for a Licence) Order 2001.
Guaranteed Standards of Performance	the standards of service set out in the Electricity (Standards of Performance) Regulations 2015 (as amended from time to time).
High-Cost Project Threshold	is defined in paragraph 1.16.
HV	more than 1kV but not more than 22kV
Independent Connections Provider (ICP)	a person with sufficient accreditation to carry out all or part of the Contestable Work.
Interruptions Incentive Scheme	the scheme which provides incentives on us to deliver a good level of performance in respect of customer interruptions and customer minutes lost.
ISOP	means the Independent System Operator and Planner as designated by the Secretary of State under section 162 of the Energy Act 2023 as the holder of the ESO Licence.
Land Rights	all such rights in, under or over Land as are necessary for the construction, installation, operation, repair, maintenance, renewal or use of the Contestable Work or Non-Contestable Work.
Licensed Distribution Network Operator (LDNO)	the holder of a Licence to distribute electricity.
LV	not more than 1kV.
Maximum Capacity	means in relation to any connection the maximum amount of electricity, as agreed with us and expressed in kW or kVA, that can be imported from or exported onto our Distribution System.

Meter Point Administration Number (MPAN)	is a 21 digit reference to uniquely identify Exit/ Entry Point, such as individual domestic residences.
Minimum Scheme	is defined in paragraphs 1.1 to 1.7.
New Fault Level Capacity	is defined in paragraph 1.29.
New Network Capacity	is defined in paragraph 1.29.
Non-Curtailable Connection	means a connection which is not a Curtailable Connection.
Outline Planning Permission	a decision in writing by the relevant planning authority on the general principles of how a site can be developed, which is subject to subsequent approval of one or more reserved matters.
Point of Connection (POC)	is the point (or points) of physical connection to our existing Distribution System.
Premises	means any land, building or structure.
Reinforcement	is defined in paragraphs 1.17 to 1.27.
Relevant Section of Network	is defined in paragraph 1.29.
Rent-a-Jointer Services	the service relating to hiring of resource from us to facilitate the provision of unmetered connections.
Required Capacity	is defined in paragraph 1.29.
Scheme	our network design to provide the connection.
Speculative Developments	is defined in paragraph 1.48.
Supplier	a person who holds a Supply Licence.
Supply Licence	a licence granted under section 6(1)(d) of the Act.

Supply Number	a unique identifier of those Entry/ Exit Points on the Distribution System which are used for the purposes of either taking a supply of electricity or for the connection of a distributed generator, and which forms the basis of the metering point record on the Company's registration system.
Temporary Connections	is defined in paragraph 1.24.
Validity Period	the period for which a connection Offer or POC Offer is open for acceptance.
Voltage of Connection	is the voltage at the POC between the existing distribution network and the assets used to provide the connection. For clarity, this is not necessarily the voltage of supply to the Customer.
Voltage Level	is the voltage at the transforming point between two points on the Distribution System that is directly associated with the Customer's connection. The higher voltage is one Voltage Level above the Voltage Level of the POC.
Wide Area Scheme	is defined in paragraph 1.40.
Working Day	any day other than a Saturday, a Sunday, Christmas Day, Good Friday or a day which is a bank holiday within the meaning of the Banking and Financial Dealings Act 1971.