

## SCHEDULE 17 – EHV CHARGING METHODOLOGY (FCP MODEL)

### 1. INTRODUCTION

**This Schedule 17, version 14.1, is to be used for the calculation of Use of System Charges which will become effective from, 01 April 2022 and remain effective until superseded by a revised version.**

1.1 This Schedule 17 sets out one of the two EHV Distribution Charging Methodologies (EDCM). The other EDCM is set out in Schedule 18.

1.2 This Schedule 17 sets out the methods, principles, and assumptions underpinning the EDCM for the calculation of Use of System Charges by the DNO Parties with the following Market Domain I.D.s:

HYDE;

SOUT;

SPOW;

MANW;

EMEB; and

MIDE.

1.3 In order to comply with this methodology statement when setting distribution Use of System Charges the DNO Parties referred to above will populate the following EDCM model versions:

(a) for charges effective from 1 April 2020:

(i) where the Authority has given no direction under Clause 19.1B, EDCM model version FCP v3 as issued by the Panel in accordance with Clause 14.5.3; or

(ii) where the Authority has given direction under Clause 19.1B that periods of notice described in Clause 19.1A need not apply, EDCM model version FCP v3(332) as issued by the Panel in accordance with Clause 14.5.3;

(b) for charges effective from 1 April 2021:

- (i) where the Authority has given no direction under Clause 19.1B, EDCM model version FCP v7 as issued by the Panel in accordance with Clause 14.5.3; or
- (ii) where the Authority has given direction under Clause 19.1B that periods of notice described in Clause 19.1A need not apply, EDCM model version FCP v7(379) as issued by the Panel in accordance with Clause 14.5.3; or
- (c) for charges effective from 1 April 2022 or later:
  - (i) where the Authority has given no direction under Clause 19.1B, EDCM model version FCP v9 as issued by the Panel in accordance with Clause 14.5.3; or
  - (ii) where the Authority has given direction under Clause 19.1B that periods of notice described in Clause 19.1A need not apply, EDCM model version FCP v10 as issued by the Panel in accordance with Clause 14.5.3.

### **Main Steps**

- 1.4 The EDCM involves four main steps.
- 1.5 Step 1 is the application of load flow techniques and the LRIC or FCP methodologies to determine an EDCM tariff element, known as Charge 1, which represents costs associated with demand-led reinforcement, estimated by reference to power flows in the maximum demand scenario.
- 1.6 Step 2 involves the allocation of DNO Party costs to Connectees using appropriate cost drivers.
- 1.7 Step 3 adds a scaling element to charges which is related to Allowed Revenue.
- 1.8 Step 4 uses CDCM charges to determine the element of portfolio charges to be applied in the case of DNO/IDNO Parties who are supplied from the DNO Party's network at voltages higher than the scope of CDCM charges.
- 1.9 Figure 1 provides a diagrammatic overview of the steps involved for import charges.

Figure 1 Diagrammatic overview of the EDCM for import

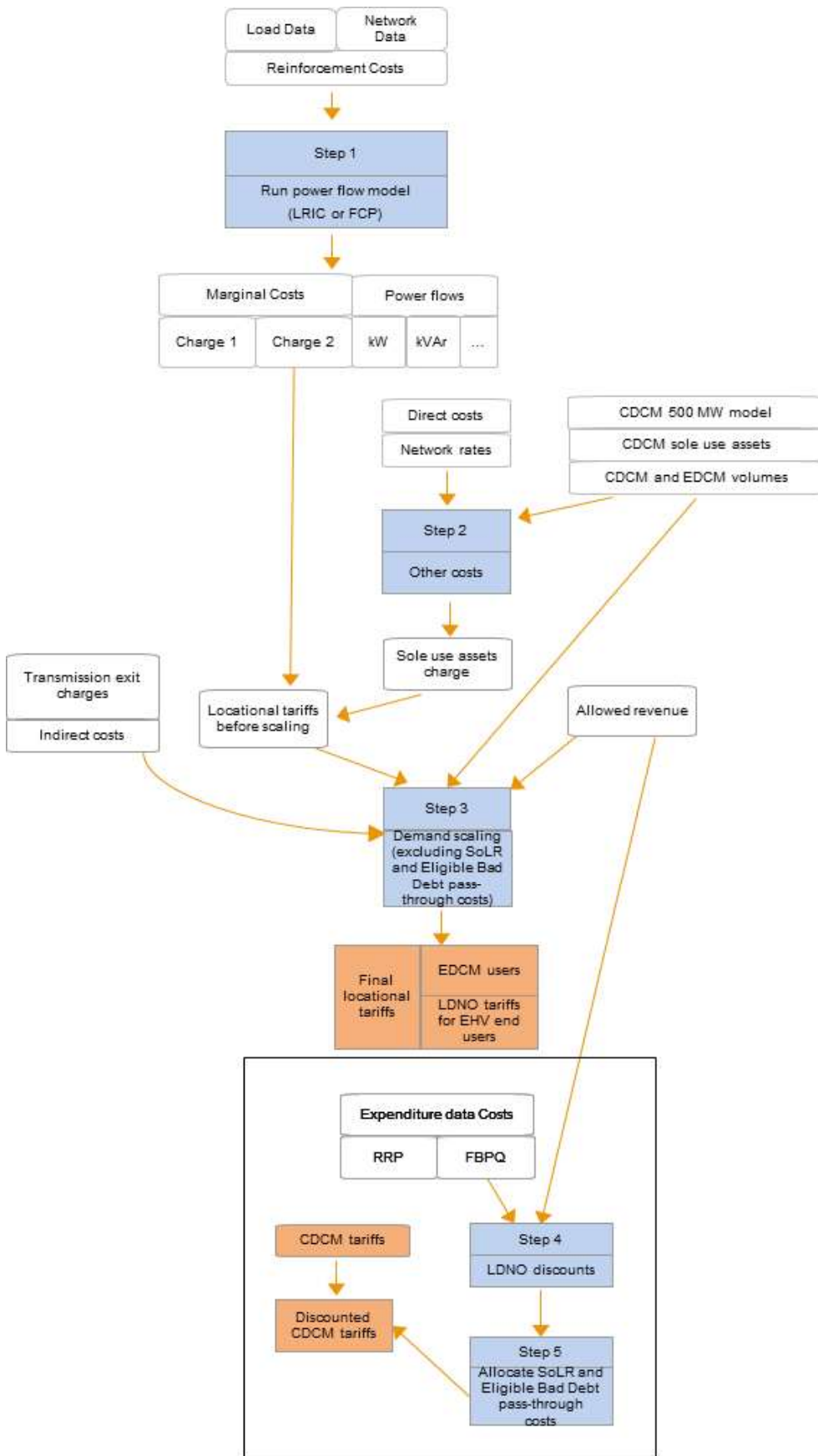

## 2. FORWARD COST PRICING ANALYSIS

### Introduction

- 2.1 The Forward Cost Pricing (FCP) model is used to calculate annual incremental charges for EDCM Connectees. A fundamental principle of the FCP model is that the revenue recovery generated from its incremental charges is equal to the expected cost of reinforcement. These incremental charges provide cost signals relative to the available capacity in a Network Group, the expected cost of reinforcement of the Network Group and the time before the reinforcement is expected to be necessary. Load and generation incremental charges are derived separately.
- 2.2 The key FCP modelling steps consist of:
- (a) configuration of the Authorised Network Model;
  - (b) development of demand data sets;
  - (c) definition of Network Groups;
  - (d) power flow analyses:
    - i) assessment of network security requirements (load);
    - ii) assessment of network security requirements (generation);
  - (e) calculation of reinforcement costs; and
  - (f) calculation of FCP load incremental charges (£/kVA/annum);

### Configuration of the Authorised Network Model

- 2.3 Power flow analyses are performed on the Authorised Network Model. This is a representation of the DNO Party's EHV network (from the Grid Supply Point level down to and including the HV busbars at the EHV/HV transformation level) expected to exist and be operational in the Regulatory Year for which Use of System Charges are being calculated (save that, until 5 November 2016, where charges are being calculated for two or more Regulatory Years, the same Authorised Network Model will be used for all the years).

- 2.4 Guidance on the configuration of the Authorised Network Model is provided in the section 4 (Authorised Network Model) of Annex 1.

### **Development of Network Demand Data sets**

- 2.5 Load data used in the power flow analyses is based on network demand data from the DNO Party's Long Term Development Statement (or LTDS), which contains a five-year forecast of substation maximum demands. A 10-year forecast is derived by extrapolation of the five-year forecast. Existing generation data is based on the Maximum Export Capacities of EDCM Generation.
- 2.6 Guidance on the development of the Network Demand Data sets is provided in section 5 (Network Demand Data) of Annex 1.

### **Definition of Network Groups**

- 2.7 The Authorised Network Model is split into Network Groups, thereby reflecting the zonal nature of the FCP model. A Network Group is a contained portion of the Authorised Network Model defined by physical, operational and technical boundaries that is not electrically connected to another part of the network at the same voltage level under normal operating conditions. A Network Group is defined as the network normally supplied from a Grid Supply Point (GSP) substation, a Bulk Supply Point (BSP) substation, or a Primary Substation. In situations where GSP substations, BSP substations or Primary Substations are operated in parallel, the network associated with such parallel GSP substations, BSP substations or Primary Substations is considered as one Network Group.
- 2.8 Guidance relating to the definition of Network Groups is presented in section 6 (Network Groups) of Annex 1.

### **Power Flow Analyses**

- 2.9 Power Flow analyses are undertaken using AC load flow methods.

### **Assessment of network security requirements (load)**

- 2.10 Contingency analyses are performed on the Authorised Network Model to which the relevant Network Demand Data sets have been applied. This is done in order to identify

all load-related reinforcements expected within the 10-year horizon in line with network planning security requirements (as can be found in ER P2/6). N-1 and, where required, N-2 contingency analyses are performed on the Authorised Network Model for each year within the 10-year horizon.

- 2.11 Reinforcements identified within the 10-year horizon are used to determine FCP load incremental charges. As the power flow analyses progress through the 10-year planning period the same reinforcements will be identified - only newly-identified reinforcements in each year are considered in order to avoid double-counting. The analysis considers thermal ratings only.
- 2.12 Guidance relating to these power flow analyses is presented in section 7 (Power flow analysis process) of Annex 1.

### Calculation of reinforcement costs

- 2.13 It is assumed that the reinforcement or any Branch is undertaken in a standardised way with standardised costs. In practice, the design data used by the DNO Party to prepare offers for connection to its Distribution System should be used when determining the extent and likely cost of reinforcement.
- 2.14 Guidance relating to the calculation of reinforcement costs is presented in section 8 (Calculation of reinforcement costs) of Annex 1.

### Calculation of FCP load incremental charges

- 2.15 The FCP load incremental charge for a Network Group is derived from all expected reinforcements identified within the 10-year horizon period within that Network Group.
- 2.16 The FCP load incremental charging function is in integral form with exponential load growth and continuous discounting applied. The following charging function is used to derive the Network Group FCP load incremental charge (£/kVA/annum) for EDCM Customers:

$$FCP_{load} = \sum_j \frac{i \left( \frac{A_j}{C_l} \right) \left( \frac{D}{C_l} \right)^{\frac{2i}{T}-1}}{1 - e^{-iT}}$$

**Where:**

*FCPload* = FCP load incremental charge (£/kVA/annum)

*j* = in index of Branch whose reinforcement is required in the planning period

*i* = discount rate, which is set to equal the latest pre-tax real weighted average cost of capital (CC below) for each DNO Party calculated using the following formula:

$$CC = (\text{Gearing Assumption} \times \text{Pre-Tax Cost of Debt}) + (1 - \text{Gearing Assumption}) * (\text{Post Tax Cost of Equity} / (1 - \text{Corporation Tax Rate}))$$

where:

Gearing Assumption is set to the ‘Notional gearing’ value for the regulatory year for which tariffs are being set in the latest version of the PCFM (InputSummary sheet, Finance inputs, Vanilla allowed return on capital) prepared for the relevant DNO Party for publication with such tariff setting on the DNO Party’s website;

Pre-Tax Cost of Debt is set to the ‘Allowed return on debt’ value for the regulatory year for which tariffs are being set in the latest version of the PCFM (InputSummary sheet, Finance inputs, CAPM calculator tool: allowed return on debt) prepared for the relevant DNO Party for publication with such tariff setting on the DNO Party’s website;

Post Tax Cost of Equity is set to the ‘Allowed return on equity’ value for the regulatory year for which tariffs are being set in the latest version of the PCFM (InputSummary sheet, Finance inputs, CAPM calculator tool: allowed return on equity) prepared for the relevant DNO Party for publication with such tariff setting on the DNO Party’s website; and

Corporation Tax Rate is set to the ‘Corporation tax rate’ value for the regulatory year for which tariffs are being set in the latest version of the PCFM (InputSummary sheet, Tax, Tax policy) prepared for the relevant DNO Party for publication with such tariff setting on the DNO Party’s website.

In the event of any value not being available from the above data sources, the DNO Party will prepare a forecast of the value to be used in the CC formula instead.

The CC value is calculated as a percentage, and rounded to two decimal places.

- $A_j$  = total cost (£) of asset “j” reinforcement in the considered Network Group over 10-year period
- $l$  = index of the total load level at which reinforcement of Branch “j” is required
- $C_l$  = total demand (kVA) of the Network Group, in the Maximum Demand Scenario, in the year  $Y_l$  in which reinforcement of Branch “j” is required
- $D$  = total demand (kVA) in the Network Group in the first year of the 10-year horizon in the Maximum Demand scenario
- $g_l$  = annual average load growth rate corresponding to the year in which the reinforcement is expected to be required (see below)
- $T$  = 10 years over which the reinforcement cost is recovered

- 2.17 The annual average Network Group load growth rate corresponding to the year in which the reinforcement is expected,  $g_l$ , is calculated by:

$$g_l = \frac{\ln\left(\frac{C_l}{D}\right)}{Y_l}$$

Where:

- $gl$  = annual average load growth rate corresponding to the year in which the reinforcement is expected to be required
- $Yl$  = number of years before the reinforcement of Branch “j” is required
- $Cl$  = total demand (kVA) of the Network Group, in the Maximum Demand Scenario, in the year  $Yl$  in which reinforcement of Branch “j” is required
- $D$  = total demand (kVA) in the Network Group in the first year of the 10-year horizon in the Maximum Demand scenario

2.18 Guidance relating to the calculation and application of FCP load incremental charges is presented in section 9.1 (FCP load incremental charge) of Annex 1.

## Outputs

2.19 The outputs of the FCP modelling are:

- (a) Network Group ID;
- (b) Charge 1: Demand (load) charge (£/kVA/annum);
- (c) Parent Network Group ID;
- (d) Active Power (kW) of demand (load) for Maximum Demand Scenario;
- (e) Reactive Power (kVAr) of demand (load) for Maximum Demand Scenario;
- (f) Active Power (kW) of demand (generation) for Maximum Demand Scenario; and
- (g) Reactive Power (kVAr) of demand (generation) for Maximum Demand Scenario.

## 3. EDCM CHARGE COMPONENTS FOR CONNECTEES

3.1 This section sets out the different charge components that will apply to Connectees under the EDCM. Charge components are the outputs of the EDCM and make up the distribution use of system charges applied to Connectees.

3.2 In the EDCM, each set of charges comprises import rates, export rates, or both, as applicable to the Connectee. The DNO Party's Relevant Charging Statement includes information that enables a Supplier to determine which Designated EHV Property each set of charges applies to.

3.3 Demand charges under the EDCM comprise the following individual components:

- Import fixed charges.
- Import capacity charges.
- Exceeded import capacity charges.
- Unit rate charges for consumption at the time of the DNO Party's peak (super-red time band).

3.4 The EDCM charge components for import are listed in table 3.4.

**Table 3.4 Charge components for import**

<b>Charge component</b>	<b>Unit</b>
Import fixed charge	p/day
Import capacity charge	p/kVA/day
Exceeded import capacity charge	p/kVA/day
Super-red import unit charge	p/kWh

3.5 Generation charges under the EDCM comprise the following individual components:

- Export fixed charges
- Export capacity charges
- Exceeded export capacity charges
- Export super-red unit rate (credit)

3.6 The EDCM charge components for export are listed in table 3.6.

**Table 3.6 Charge components for export**

Charge component	Unit
Export fixed charge	p/day
Export capacity charge	p/kVA/day
Exceeded export capacity charge	p/kVA/day
Export super-red unit rate	p/kWh

3.7 The next section details the calculation of the elements that determine the charge components described above.

#### **4. CALCULATION OF EDCM CHARGE COMPONENTS**

4.1 EDCM charge components are derived from tariff elements. This section describes the method for calculating each of these charge elements.

#### **5. CHARGEABLE EXPORT CAPACITY FOR EXPORT CHARGES**

5.1 The Chargeable Export Capacity for each Connectee is defined as the Maximum Export Capacity minus any capacity that is exempt from use of system charges in the charging year.

#### **6. APPLICATION OF FCP CHARGE 1**

6.1 Each tariff in the model is linked to one FCP location or network group. Each FCP network group may be linked to a parent FCP network group and a grandparent FCP network group. Each FCP network group may have a charge 1 in £/kVA/year associated with it.

6.2 The import charges for the application of charge 1 is given by the formulas:

For Connectees with zero average kW/kVA:

$$[\text{p/kWh super-red rate}] = ([\text{parent charge 1 } \text{£/kVA/yr}] * (\text{abs}[A1] / (\text{SQRT}(A1^2 + R1^2))) / [\text{Super-red hours}] * 100) + ([\text{grandparent charge 1 } \text{£/kVA/yr}] * (\text{abs}[A2] / (\text{SQRT}(A2^2 + R2^2))) / [\text{Super-red hours}] * 100)$$

$$[p/kVA/day\ capacity\ charge] = ([network\ charge\ 1\ \pounds/kVA/year] / [days\ in\ Charging\ Year] * 100) + ([parent\ charge\ 1\ \pounds/kVA/yr] * (-R1 * Average\ kVAr/kVA) / (SQRT(A1^2 + R1^2))) / [days\ in\ Charging\ Year] * 100 + ([grandparent\ charge\ 1\ \pounds/kVA/yr] * (-R2 * [Average\ kVAr/kVA]) / (SQRT(A2^2 + R2^2))) / [days\ in\ Charging\ Year] * 100$$

For all other Connectees:

$$[p/kWh\ super-red\ rate] = [parent\ charge\ 1\ \pounds/kVA/yr] * (abs[A1] - (R1 * ([Average\ kVAr/kVA] / [Average\ kW/kVA]))) / (SQRT(A1^2 + R1^2)) / [Super-red\ hours] * 100 + ([grandparent\ charge\ 1\ \pounds/kVA/yr] * (abs[A2] - (R2 * ([Average\ kVAr/kVA] / [Average\ kW/kVA]))) / (SQRT(A2^2 + R2^2)) / [Super-red\ hours] * 100$$

$$[p/kVA/day\ capacity\ charge] = [network\ group\ charge\ 1\ \pounds/kVA/year] / [days\ in\ Charging\ Year] * 100$$

Where:

A1 and R1 are the values of the active power flow and reactive power flow modelled through the parent network group in the maximum demand scenario.

A2 and R2 are the values of the active power flow and reactive power flow modelled through the grandparent network group in the maximum demand scenario.

If both A1 and R1 are equal to zero, in respect of that network level in the formulas above, the term  $(abs[A1] / (SQRT(A1^2 + R1^2)))$  is set equal to 1,  $(-R1 * Average\ kVAr/kVA) / (SQRT(A1^2 + R1^2))$  is set equal to zero, and  $([Average\ kVAr/kVA] / [Average\ kW/kVA]) / (SQRT(A1^2 + R1^2))$  is also set to zero.

If both A2 and R2 are equal to zero, in respect of that network level in the formulas above, the term  $(abs[A2] / (SQRT(A2^2 + R2^2)))$  is set equal to 1,  $(-R2 * Average\ kVAr/kVA) / (SQRT(A2^2 + R2^2))$  is set equal to zero, and  $([Average\ kVAr/kVA] / [Average\ kW/kVA]) / (SQRT(A2^2 + R2^2))$  is also set to zero.

Any negative contributions to the [p/kVA/day capacity charge] or the [p/kWh super-red rate] from the parent or the grandparent network groups are set to zero.

Super red hours are the number of hours in the DNO Party's super-red time band.

The average kW/kVA and average kVAr/kVA figures are forecasts for the Charging Year, based on data from the most recent regulatory year for which data were available in time for setting charges for the Charging Year. Specifically, active and reactive power consumptions are averaged over a super-red time band, which is a seasonal time of day period determined by the DNO Party to reflect the time of peak, and then divided by the Maximum Import Capacity (averaged over the same financial year). If the DNO Party considers that the reactive consumption data relates to export rather than import (e.g. the average kVAr figure exceeds half of the Maximum Import Capacity) then the Maximum Import Capacity in the denominator should be replaced by the Maximum Export Capacity of the same Connectee. The average kVAr divided by kVA is restricted to be such that the combined active and reactive power flows cannot exceed the Maximum Import Capacity.

- 6.3 Charge 1 is applied to export charges as a credit. The credit is expressed as a negative charge rate in p/kWh and is applied in respect of active power units exported during the DNO Party's super-red time band. The credit rate is set to zero for Connectees who are assigned an F Factor of zero. The credit rate is calculated as follows:

$$[\text{p/kWh super-red export rate}] = -100 * [\text{Proportion eligible for charge 1 credits}] \\ * ([\text{network charge 1 } \text{£/kVA/year}] + [\text{parent charge 1 } \text{£/kVA/year}] + [\text{grandparent} \\ \text{charge 1 } \text{£/kVA/year}]) * ([\text{Chargeable export capacity}]/[\text{Maximum export capacity}]) \\ /[\text{number of hours in the super-red time band}]$$

Where:

The proportion eligible for charge 1 credits is zero if the F factor that is assigned to the Connectee as described in the FCP methodology is equal to zero, and 1 otherwise.

The super-red generation rate is not applied to Connectees with zero Chargeable Export Capacity.

## 7. NO APPLICATION OF NEGATIVE CHARGES

- 7.1 Under FCP, charge 1 is either zero or positive. Any negative values of Charge 1 are set to zero.

**8. DEMAND SIDE MANAGEMENT (DSM) AND GENERATION SIDE MANAGEMENT (GSM)**

- 8.1 Some EDCM Customers are subject to demand side management (DSM) or generation side management (GSM) agreements.
- 8.2 For Connectees with DSM agreements, let “chargeable capacity” be equal to the Maximum Import Capacity minus the capacity that is subject to restrictions under a DSM agreement. These restrictions would take into account any seasonal variations built into these agreements.
- 8.3 For Connectees with DSM agreements, DSM-adjusted local and remote (or parent and grandparent) elements of the FCP charge are calculated as the product of the ratio of “chargeable capacity” to Maximum Import Capacity and the unadjusted elements of the FCP charge. Where the Maximum Import Capacity is zero, this ratio is set to 1. The DSM-adjusted local element of the FCP charge 1 is applied to the Maximum Import Capacity, and the DSM-adjusted remote (or parent and grandparent) element of the FCP charge 1 is applied to units consumed during the super-red time band.
- 8.4 For Connectees with GSM agreements, no adjustments are made in the EDCM.

**9. TRANSMISSION CONNECTION (EXIT) CHARGES FOR DEMAND**

- 9.1 A separate transmission exit charge is applied to demand tariffs.
- 9.2 A single charging rate, in p/kW/day is calculated as follows:

Transmission exit charging rate p/kW/day =  $100 / DC * ISOP \text{ charge} / (\text{CDCM system maximum load} + \text{total EDCM peak time consumption})$

Where:

DC is the number of days in the Charging Year.

ISOP charge is the DNO Party’s forecast annual expenditure on transmission connection point charges in £.

CDCM system maximum load is the forecast system simultaneous maximum load from CDCM Connectees (in kW) from CDCM table 2506.

Total EDCM peak time consumption (in kW) calculated by multiplying the Maximum Import Capacity of each Connectee by the forecast peak-time kW divided by forecast maximum kVA of that Connectee (adjusted for losses to transmission and, if necessary, for Connectees connected for part of the Charging Year) and aggregating across all EDCM Customer demand.

- 9.3 The single p/kW/day charging rate is converted into a p/kVA/day import capacity based charge for each EDCM Connectee as follows:

Transmission exit charge p/kVA/day = [Transmission exit charging rate in p/kW/day]  
 \* [Forecast peak-time kW divided by kVA of that Connectee, adjusted for transmission losses and, if necessary for Connectees connected part of the year]

## 10. **TRANSMISSION CONNECTION (EXIT) CREDITS FOR GENERATORS**

- 10.1 A capacity-based credit related to transmission exit is applied to generation tariffs.
- 10.2 Transmission exit credits are paid to generators that have an agreement with the DNO, the terms of which require the generator, for the purposes of P2/6 compliance, to export power during supergrid transformer (SGT) outage conditions.
- 10.3 The rate in p/kVA/day for each generation customer would be calculated as follows:

Transmission exit credit p/kVA/day = -[Transmission exit charging rate in p/kW/day]  
 \* [Capacity eligible for credits in kW] / [Chargeable Export Capacity in kVA of that Connectee]

Where:

Transmission exit charging rate in p/kW/day is calculated as described for demand tariffs.

Capacity eligible for credits (in kW) is the capacity that is made available by the generator under the agreement with the DNO.

Chargeable Export Capacity (in kVA) is the forecast average value of the maximum export capacity of the generator over the charging year, less any capacity that is exempt from use of system charges in the charging year.

The generation transmission connection (exit) rate is not calculated for Connectees with zero Chargeable Export Capacity.

- 10.4 Transmission connection (exit) credits are applied to the Chargeable Export Capacity (in kVA)

## 11. REACTIVE POWER CHARGES

- 11.1 The EDCM does not include a separate charge component for any reactive power flows.

## 12. EXPORT CAPACITY CHARGES

- 12.1 The EDCM includes an export capacity charge.
- 12.2 EDCM DG revenue target £/year =  $GL * [Total\ 2005-2010\ EDCM\ generation\ capacity] / ([Total\ 2005-2010\ EDCM\ generation\ capacity] + [Total\ 2005-2010\ CDCM\ generation\ capacity]) + AGPa * [Total\ post-2010\ EDCM\ generation\ capacity] / ([Total\ post-2010\ EDCM\ generation\ capacity] + [Total\ post-2010\ CDCM\ generation\ capacity]) + (OM * ([Total\ Pre-2005\ EDCM\ DG\ capacity] + [Total\ Post-2010\ EDCM\ DG\ capacity]))$

Where:

GL is the incentive revenue in the charging year in respect of generators connected between 2005 and 2010 calculated for the charging year as in paragraph 11.10 of the Special Conditions of the Electricity Distribution Licence (CRC11). From and including Regulatory Year 2015/2016 GL is zero.

AGPa is the average of the values of GPa for the charging year and each of the two years immediately preceding the charging year. For Regulatory Year 2014/2015 GPa is calculated using a modified version of the formula in paragraph 11.6 of the Electricity Distribution Licence (CRC11) resulting from DPCR5. To calculate GPa, the term GPX is replaced by the term GPS in the formula in paragraph 11.6. Both GPX and GPS are defined in paragraph 11.7 of the same document. For Regulatory Years 2015/16 onwards GPa is zero.

Total Pre-2005 EDCM DG capacity is the aggregate maximum export capacity of all non-exempt EDCM generators that connected before 1 April 2005, adjusted for part-year connected generators. In the case of generators that have subsequently increased their maximum export capacity, the part of their capacity that was added after 1 April 2005 would be ignored.

Total 2005–2010 EDCM generation capacity is the sum of the maximum export capacities of all non-exempt EDCM generators that connected between 1 April 2005 and 31 March 2010, adjusted for part-year connected generators.

Total Post–2010 EDCM generation capacity is the sum of the maximum export capacities of all non-exempt EDCM generators that connected on or after 1 April 2010, adjusted for part-year connected generators. In the case of generators that originally connected before 1 April 2010 and have increased their maximum export capacity on or after 1 April 2010, the capacity that was added after 1 April 2010 should be included.

Total 2005–2010 CDCM generation capacity is the sum of the maximum export capacities of all non-exempt CDCM generators that connected between 1 April 2005 and 31 March 2010, adjusted for part-year connected generators.

Total Post–2010 CDCM generation capacity is the sum of the maximum export capacities of all non-exempt CDCM generators that connected on or after 1 April 2010, adjusted for part-year connected generators.

OM is an allowance in £/kW in respect of the operational and maintenance costs for assets that are deemed to have been installed for the purposes of connecting generators to the distribution network. The value of OM is set to £0.20/kW.

12.3 A fixed export capacity charge in p/kVA/day is calculated as follows:

$$\text{Fixed export capacity charge in p/kVA/day} = (100 / \text{DC}) * [\text{EDCM DG revenue target}] / [\text{Total EDCM generation capacity}]$$

Where:

EDCM DG revenue target in £/year is calculated as described above

Total EDCM generation capacity (in kVA) is the aggregate Chargeable Export Capacity of all Connectees, adjusted, if necessary for Connectees connected part of the year.

The fixed export capacity charge in p/kVA/day is applied to the Chargeable Export Capacity of each EDCM Connectee.

**13. ALLOCATION DRIVERS FOR OTHER CHARGE ELEMENTS IN THE EDCM**

13.1 In addition to charges calculated using the FCP and LRIC methodologies and transmission connection (exit) charges, the EDCM includes charge elements relating to:

- the DNO Party's direct operating costs (this includes inspection and maintenance costs, operating expenditure relating to fault repairs and the cost of tree cutting);
- the DNO Party's indirect costs. (these are costs that are not directly related to network assets, such as business support costs);
- the DNO Party's network rates (these are business rates paid by DNO Parties);  
and
- the DNO Party's residual revenue.

13.2 The residual revenue is that part of the DNO Party's Allowed Revenue less any revenue relating to recovery of the DNO Party's Supplier of Last Resort and Eligible Bad Debt pass-through costs that has not been pre-allocated to demand charges using cost-based charge elements.

13.3 EDCM charge elements are determined using allocation drivers. The following allocation drivers are used in the EDCM:

- The value of assets that are for the sole use of a Connectee (sole use assets). This is relevant to import and export charges.
- The value of site-specific shared network assets used by the Connectee. This is relevant to import charges only.
- The sum of historical consumption at the time of system peak and 50 per cent of Maximum Import Capacity. This is relevant to import charges only.
- Chargeable Export Capacity. This is relevant to export charges only.

13.4 The methods used to determine the value of sole use assets and shared site-specific shared network assets are described below.

## 14. SOLE USE ASSETS

- 14.1 The value of a customer's sole use assets used is expressed in the form of a modern equivalent asset value (MEAV) in £.
- 14.2 Sole use assets are assets in which only the consumption or output associated with a single Connectee can directly alter the power flow in the asset, taking into consideration all possible credible running arrangements, i.e. all assets between the Connectee's Entry/Exit Point(s) and the Point(s) of Common Coupling with the general network are considered as sole use assets.
- 14.3 The Point of Common Coupling for a particular single Connectee is the point on the network where the power flow associated with the single Connectee under consideration, may under some (or all) possible arrangements interact with the power flows associated with other Connectees, taking into account all possible credible running arrangements.
- 14.4 Where a single site has both import and export charges, associated with import and export meter registrations, the sole use assets are allocated between the import and export proportionally to Maximum Import Capacity and Maximum Export Capacity respectively. Where any part of the Maximum Export Capacity associated with an export meter registration is exempt from use of system charges in the charging year, the value of sole use assets allocated to the export tariff is reduced by multiplying it by the ratio of the Chargeable Export Capacity to the Maximum Export Capacity.
- 14.5 Where an EDCM site was originally connected as a single Connected Installation, and has subsequently split into multiple Connected Installations, these sites continue to be considered as one site for the purposes of determining sole use assets. The sole use asset MEAV is allocated between these Connected Installations in proportion to their Maximum Import Capacities and Maximum Export Capacities.

## **15. SITE-SPECIFIC SHARED NETWORK ASSETS**

- 15.1 A Connectee's notional site-specific shared network asset value is the value of network assets that are deemed to be used by that Connectee, other than sole use assets as defined earlier.
- 15.2 The value of notional site-specific shared assets used by each Connectee is expressed in the form of a modern equivalent asset value (MEAV) in £.
- 15.3 The value of shared network assets used by each demand Connectee is calculated as set out below.
- 15.4 Five levels are defined for the network's assets:
- Level 1 comprises 132 kV circuits.
  - Level 2 comprises substations with a primary voltage of 132 kV and a secondary voltage of 22 kV or more.
  - Level 3 comprises circuits of 22 kV or more but less than 132 kV.
  - Level 4 comprises substations with a primary voltage of 22 kV or more but less than 132 kV and a secondary voltage of less than 22 kV.
  - Level 5 comprises substations with a primary voltage of 132 kV and a secondary voltage of less than 22 kV.
- 15.5 In some cases, it might be appropriate to treat 66 kV equipment as being equivalent to 132 kV equipment and allocate Connectees to categories accordingly.
- 15.6 EDCM Customers are split into 15 categories based on the parts of the EHV network they are deemed to use. This is based on the Point of Common Coupling. The Point of Common Coupling might be at a different voltage than the Connectee's connection, and might also be at a different voltage than the voltage of connection when the Connectee was connected.

**Table 15.6 Categorisation of EDCM Customers**

<b>Category</b>	<b>Definition</b>
Category 0000	Point of Common Coupling at the GSP, whether the GSP is shared or not.
Category 1000	In England or Wales only, Point of Common Coupling at a voltage of 132 kV, unless the Connectee qualifies for category 0000.
Category 1100	Point of Common Coupling at 22 kV or more on the secondary side of a substation where the primary side is attached to a 132 kV circuit.
Category 0100	Point of Common Coupling at 22 kV or more, but less than 132 kV, on the secondary side of a substation where the primary side is attached at 132 kV to a co-located GSP with no use of any 132 kV circuits.
Category 1110	Point of Common Coupling at a voltage of 22 kV or more, but less than 132 kV, not at a substation, fed from a substation whose primary side is attached to a 132 kV distribution circuit.
Category 0110	Point of Common Coupling at a voltage of 22 kV or more, but less than 132 kV, not at a substation, fed from a substation whose primary side is attached at 132 kV to a co-located GSP with no use of any 132 kV circuits.
Category 0010	Point of Common Coupling at a voltage of 22 kV or more, but less than 132 kV, fed from a GSP with no intermediate transformation.
Category 0001	Point of Common Coupling at a voltage of less than 22 kV on the secondary side of a substation where the primary side is attached at 132 kV to a co-located GSP with no circuit.
Category 0002	Point of Common Coupling at a voltage of less than 22 kV on the secondary side of a substation where the primary side is attached at 22 kV or more but less than 132 kV, to a co-located GSP with no circuit.
Category 1001	Point of Common Coupling at a voltage of less than 22 kV on the secondary side of a substation whose primary side is attached to a 132 kV distribution circuit.
Category 0011	Point of Common Coupling at a voltage of less than 22 kV on the secondary side of a substation whose primary side is at a voltage of 22 kV or more, but less than 132 kV, fed from a GSP with no intermediate transformation.

Category 0111	Point of Common Coupling at a voltage of less than 22 kV on the secondary side of a substation whose primary side is at a voltage of 22 kV or more, but less than 132 kV, fed through a distribution circuit from a substation whose primary side is attached at 132 kV to a co-located GSP with no circuit.
Category 0101	Point of Common Coupling at a voltage of less than 22 kV on the secondary side of a substation whose primary side is at a voltage of 22 kV or more, but less than 132 kV, fed from the secondary side of a co-located substation whose primary side is attached at 132 kV to a co-located GSP with no circuit.
Category 1101	Point of Common Coupling at a voltage of less than 22 kV on the secondary side of a substation whose primary side is at a voltage of 22 kV or more, but less than 132 kV, fed from the secondary side of a co-located substation whose primary side is attached to a 132 kV distribution circuit.
Category 1111	Point of Common Coupling at a voltage of less than 22 kV on the secondary side of a substation whose primary side is at a voltage of 22 kV or more, but less than 132 kV, fed through a distribution circuit from a substation whose primary side is attached to a 132 kV distribution circuit.

---

- 15.7 All references to GSP in table 15.6 above relate to interconnections with the onshore National Electricity Transmission System.
- 15.8 The figure below provides examples of Connectees who might be placed in each of the categories described above.

### Customer Categories

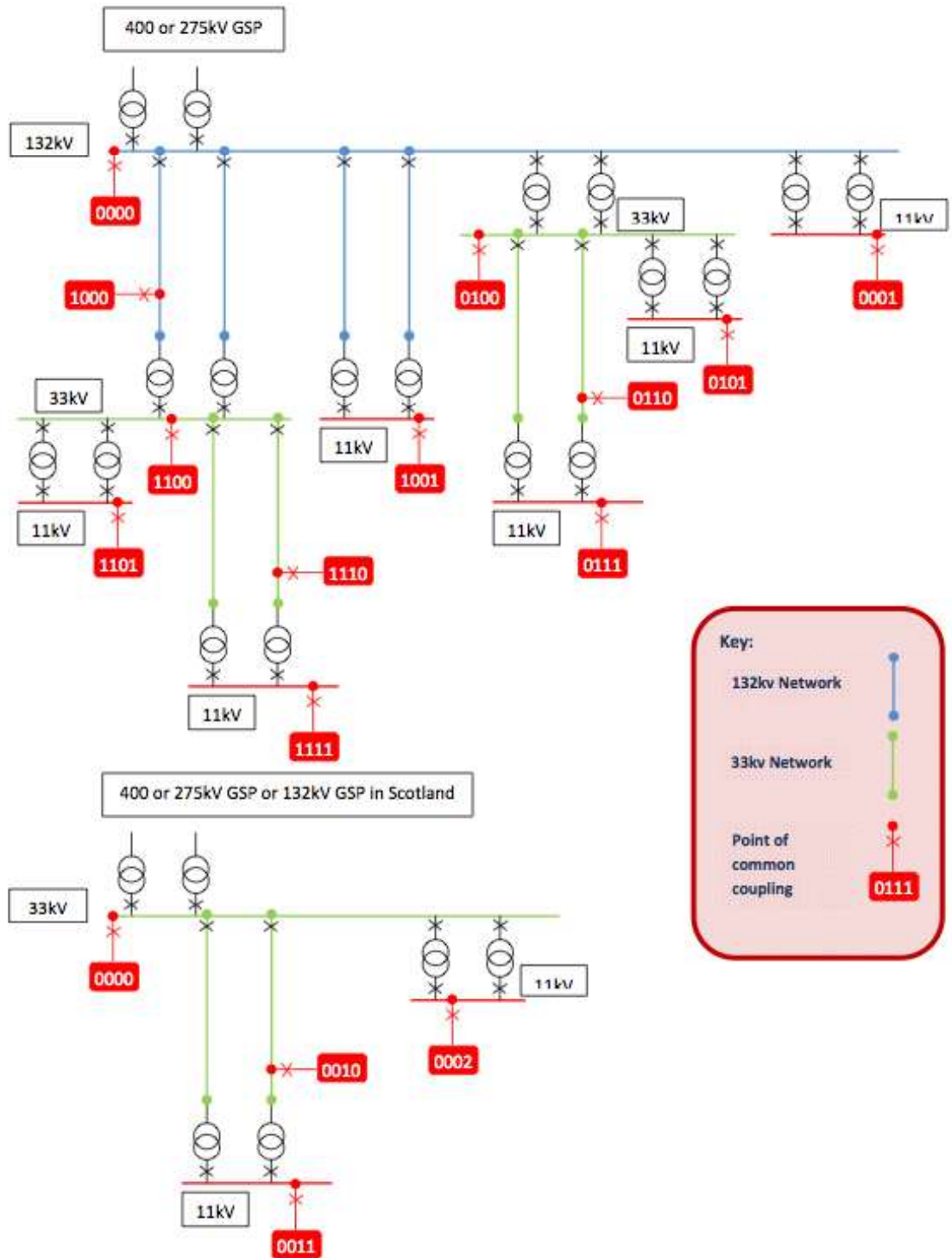

15.9 The use of each network level by each EDCM Connectee is determined according to the rules set out in table 15.9.

**Table 15.9 Use of each network level by each EDCM Connectee**

<b>EDCM Customers in category</b>	<b>Level 1</b>	<b>Level 2</b>	<b>Level 3</b>	<b>Level 4</b>	<b>Level 5</b>
Category 0000	Zero	Zero	Zero	Zero	Zero
Category 1000	Capacity kVA	Zero	Zero	Zero	Zero
Category 1100	Peak-time active kW	Capacity kVA	Zero	Zero	Zero
Category 0100	Zero	Capacity kVA	Zero	Zero	Zero
Category 1110	Peak-time active kW	Peak-time active kW	Capacity kVA	Zero	Zero
Category 0110	Zero	Peak-time active kW	Capacity kVA	Zero	Zero
Category 0010	Zero	Zero	Capacity kVA	Zero	Zero
Category 0001	Zero	Zero	Zero	Zero	Capacity kVA
Category 0002	Zero	Zero	Zero	Capacity kVA	Zero
Category 1001	Peak-time active kW	Zero	Zero	Zero	Capacity kVA
Category 0011	Zero	Zero	Peak-time active kW	Capacity kVA	Zero
Category 0111	Zero	Peak-time active kW	Peak-time active kW	Capacity kVA	Zero
Category 0101	Zero	Peak-time active kW	Zero	Capacity kVA	Zero
Category 1101	Peak-time active kW	Peak-time active kW	Zero	Capacity kVA	Zero
Category 1111	Peak-time active kW	Peak-time active kW	Peak-time active kW	Capacity kVA	Zero

15.10 Category 0000 Connectee are deemed not to use any network assets other than sole use assets.

15.11 An average network asset value per kVA (in £/kVA) is calculated in respect of each network level. The average network asset value for the network level of connection is based on the Maximum Import Capacity of the Connectee, and for network levels above on consumption at peak time.

Average network asset value for capacity at level L (£/kVA) =  $NARL * AE / (1 + DL)$

Average network asset value for demand at level L (£/kVA) =  $NARL * D * LAF$

Where:

NAR L is the network asset rate at level L in £/kW based on the 500 MW model.

DL is the Diversity Allowance from the level exit to the GSP group (from CDCM table 2611).

D is the peak time active power consumption in (kW/kVA). This is calculated as the historical peak-time kW divided by historical maximum kVA.

LAF is the loss adjustment factor to transmission from the CDCM for the network level relevant to the EDCM Customer category of that Connectee. See table 15.11 below for the correspondence between EDCM Customer categories and network levels.

AE is the active power equivalent of capacity adjusted to transmission (in kW/kVA). This is calculated by multiplying the power factor in the 500 MW model (0.95) by the loss adjustment factor to transmission for the network level relevant to that Connectee (as above).

**Table 15.11 Customer category relevant network level for loss adjustment factors**

Customer categories	Relevant network level for loss adjustment factors
0000	GSP (the loss adjustment factor is always 1 for this network level)
1000	132kV (level 1)
1100 and 0100	132kV/EHV (level 2)
1110, 0110 and 0010	EHV (level 3)
1111, 1101, 0101, 0111, 0011 and 0002	EHV/HV (level 4)
1001 and 0001	132kV/HV (level 5)

15.12 Again, separate site-specific asset values per kVA (in £/kVA) are calculated in respect of each network level. The asset value for the network level of connection is based on the Maximum Import Capacity of the Connectee, and for network levels above on consumption at peak time.

Site-specific asset value for capacity at level L (£/kVA) = NUL \* Average network asset value for capacity at level L (£/kVA)

Notional asset value for demand at level L (£/kVA) = NUL \* Average network asset value for demand at level L (£/kVA)

Where:

NUL is the network use factor for that Connectee at level L, representing the proportion of the average 500 MW model assets that the Connectee is deemed to use at that level. The methodology to calculate these network use factors is set out in Annex 2 of this Schedule.

Average notional asset value for capacity at level L is the voltage level average calculated as described earlier.

Average notional asset value for demand at level L is the voltage level average calculated as described earlier.

15.13 Network use factors for import charges of a mixed import-export site that is generation-dominated are set to default values. These default values are equal to the “collars” for each network level calculated as described in section on demand scaling. DNO Parties implementing the FCP methodology would use the rules set out in the LRIC methodology to determine whether a location is to be modelled as a generation site, and is therefore generation dominated.

15.14 The total value of the site-specific shared assets required to serve each Connectee is calculated according to the formula:

$$\text{TNA} = \text{NAC} + (\text{NAD} * (1 - (\text{Hours in super-red for which not a customer} / \text{Annual hours in super-red})) * (\text{Days in year} / (\text{Days in year} - \text{Days for which not a customer})))$$

Where:

TNA is the total site-specific network assets in £/kVA required to serve a Connectee.

NAC is the site-specific asset value in £/kVA for capacity for that Connectee aggregated across all levels.

NAD is the site-specific asset value in £/kVA for demand for that Connectee aggregated across all levels.

15.15 Total site-specific shared assets is the aggregate value (in £) of all site-specific shared assets for EDCM Connectees. This is calculated by multiplying TNA by the Maximum Import Capacity (adjusted, if necessary, for Connectees connected for part of the Charging Year), and then aggregating across all EDCM Connectees.

## **16. CALCULATION OF THE EDCM DEMAND REVENUE TARGET**

16.1 The EDCM demand revenue target is the share of the DNO Party’s Allowed Revenue less any revenue relating to recovery of the DNO Party's Supplier of Last Resort and Eligible Bad Debt pass-through costs (excluding transmission exit charges and net revenue from EDCM generation) that will be recovered from EDCM Connectees through import charges.

16.2 This section describes the method used to calculate the EDCM demand revenue target.

- 16.3 A single contribution rate for network rates is calculated for all EDCM Connectees as follows:

Network rates contribution rate (per cent) =  $NR / (\text{Total site-specific shared assets} + \text{Total EDCM sole use assets} + \text{EHV assets} + \text{HV and LV network assets} + \text{HV and LV service model assets})$

Where:

NR is the DNO Party's total expenditure on network rates.

Total site-specific shared assets is the aggregate value (in £) of all site-specific shared assets for EDCM Connectees.

Total EDCM sole use assets is the aggregate sole use asset MEAVs of all EDCM Connectees, excluding the value of sole use assets associated with exempt export capacity, adjusted for part-year connected Connectees.

EHV assets are the aggregate EHV assets in the CDCM model.

HV and LV network assets from the CDCM model.

HV and LV service model assets from the CDCM model.

- 16.4 A single contribution rate for direct operating costs is calculated for all EDCM Connectees as follows:

Direct operating costs contribution rate (per cent) =  $DOC / (\text{Total site-specific shared assets} + \text{Total EDCM sole use assets} + \text{EHV assets} + (\text{HV and LV network assets} + \text{HV and LV service model assets}) / 0.68)$

Where:

DOC is the DNO Party's total expenditure on direct operating costs.

Total site-specific shared assets is the aggregate value (in £) of all site-specific shared assets for EDCM Connectees.

Total EDCM sole use assets is the aggregate sole use asset MEAVs of all EDCM Connectees, excluding the value of sole use assets associated with exempt export capacity, adjusted for part-year connected Connectees.

EHV assets are the aggregate EHV assets in the CDCM model.

HV and LV network assets from the CDCM model.

HV and LV service model assets from the CDCM model.

0.68 is the operating intensity factor.

- 16.5 A single contribution rate for indirect costs is calculated for all EDCM Connectees as follows:

$$\text{Indirect costs contribution rate (per cent)} = \text{INDOC} / (\text{Total site-specific shared assets} + \text{Total EDCM sole use assets} + \text{EHV assets} + (\text{HV and LV network assets} + \text{HV and LV service model assets}) / 0.68)$$

Where:

INDOC is the DNO Party's total expenditure on indirect costs.

Total site-specific shared assets is the aggregate value (in £) of all site-specific shared assets for EDCM Connectees.

Total EDCM sole use assets is the aggregate sole use asset MEAVs of all EDCM Connectees, excluding the value of sole use assets associated with exempt export capacity, adjusted for part-year connected Connectees.

EHV assets are the aggregate EHV assets in the CDCM model.

HV and LV network assets from the CDCM model.

HV and LV service model assets from the CDCM model.

0.68 is the operating intensity factor.

- 16.6 Next, a residual revenue contribution rate is calculated as follows:

Residual revenue contribution rate (per cent) =  $(AR - DOC - INDOC - NR - GCN) /$   
 (Total site-specific shared assets + EHV assets + HV and LV network assets)

Where:

AR is the DNO Party's total Allowed Revenue excluding transmission exit charges in £/year and excluding any revenue relating to recovery of the DNO Party's Supplier of Last Resort and Eligible Bad Debt pass-through costs.

DOC is the DNO Party's total expenditure on direct operating costs.

INDOC is the DNO Party's total expenditure on indirect costs.

NR is the DNO Party's total expenditure on network rates.

GCN is the total forecast net revenue in £/year from the application of EDCM export charges, including the EDCM generation fixed charge. This amount is estimated by applying the calculated EDCM export charges rounded to the relevant number of decimal points.

Total site-specific shared assets is the aggregate value (in £) of all site-specific shared assets for EDCM Connectees.

EHV assets are the aggregate EHV assets in the CDCM model.

HV and LV network assets from the CDCM model.

- 16.7 The contribution rates for network rates, direct costs, indirect costs and residual revenue is converted into a £/year import capacity based contribution and a demand sole use asset MEAV based contribution for each EDCM Connectee.

Import capacity based network rates contribution for each Connectee =  $TNA * NR$   
 rate \* import capacity

Import capacity based direct operating costs contribution for each Connectee =  $TNA$   
 \* DOC rate \* import capacity

Import capacity based indirect costs contribution for each Connectee =  $TNA *$   
 INDOC rate \* import capacity

Import capacity based residual revenue contribution for each Connectee = TNA \* residual revenue rate \* import capacity

Where:

TNA is the total site-specific assets (£/kVA) for that EDCM Connectee.

NR rate is the network rates contribution rate in per cent.

DOC rate is the direct operating costs contribution rate in per cent.

INDOC rate is the indirect costs contribution rate in per cent.

Residual revenue rate is the residual revenue contribution rate in per cent.

Import capacity is the Maximum Import Capacity (adjusted, if necessary, if the Connectee is connected for part of the Charging Year) in kVA for that EDCM Connectee.

16.8 The demand sole use asset MEAV based contribution in £/year is calculated as follows:

Demand sole use asset based network rates contribution = S \* NR rate

Demand sole use asset based direct operating costs contribution = S \* DOC rate

Demand sole use asset based indirect costs contribution = S \* INDOC rate

Where

S is the MEAV of demand sole use assets of that EDCM Connectee (adjusted for Connectees connected for part of the Charging Year).

NR rate is the network rates contribution rate in per cent.

DOC rate is the direct operating costs contribution rate in per cent.

INDOC rate is the indirect costs contribution rate in per cent.

16.9 The target contributions from import capacity and demand sole use assets are aggregated across all EDCM Connectees.

- 16.10 The aggregate EDCM demand revenue target is calculated as the sum, across all EDCM demand, of the contributions based on import capacities and demand sole use assets, less the total reduction in fixed charges made to EDCM customers under paragraph 17.2. Such fixed charge reduction is to be derived as follows:

$$\text{FCR} = \text{OMR} * (\text{EHV assets} + \text{HV and LV network assets}) / (\text{Total site-specific shared assets} + \text{EHV assets} + \text{HV and LV network assets})$$

Where

OMR is the total reduction in fixed charges made to EDCM customers under paragraph 17.2, where the reduction is derived as the aggregated value of the amount each EDCM customer would have paid under paragraph 17.1 less the amount paid under 17.2 for eligible customers.

## **17. FIXED CHARGES FOR IMPORT AND EXPORT**

- 17.1 The contribution rates for network rates and direct operating costs are converted into a p/day fixed charge for the sole use assets of each EDCM Connectee as follows:

Import fixed charge on sole use assets in p/day =  $100 / \text{DC} * \text{SD} * (\text{NR contribution rate} + \text{DOC contribution rate})$

Export fixed charge on sole use assets in p/day =  $100 / \text{DC} * \text{SG} * (\text{NR contribution rate} + \text{DOC contribution rate})$

Where

DC is the number of days in the Charging Year.

SD is the MEAV of sole use assets allocated to demand of that EDCM Connectee.

SG is the MEAV of sole use assets allocated to generation of that EDCM Connectee excluding the value of sole use assets associated with exempt export capacity.

NR contribution rate is the network rates contribution rate in per cent.

DOC contribution rate is the direct operating costs contribution rate in per cent.

- 17.2 Where a customer demonstrates with written evidence to the DNO Party (or where the DNO Party has written evidence) that the customer (or its predecessors) made a capitalised O&M payment in respect of a connection to the DNO Party's network, and the period over which the O&M payment was capitalised remains unexpired, then the import fixed charge will be calculated as set out below (and the calculation for the import fixed charge in paragraph 17.1 will not apply).

The sole use assets will be split between those where capitalised O&M has been paid and those where it has not, and the fixed charge will be derived as follows:

$$p/\text{day} = (((\text{DOC rate} + \text{NR rate}) * \text{SUA MEAVU}) + (\text{NR rate} * \text{SUA MEAVP})) / (\text{days in Charging Year}) * 100$$

Where:

DOC rate is the direct operating costs contribution rate in per cent;

NR rate is the network rates contribution rate in per cent;

Where SUA MEAVU is the Modern Equivalent Asset Value of Sole Use Assets where capitalised O&M has not been paid (or the period over which it was to be capitalised has expired); and

SUA MEAVP is the Modern Equivalent Asset Value of Sole Use Assets where capitalised O&M has been paid (and the period over which it was to be capitalised has not expired).

- 17.3 For customers that are classified as exempt pre-2005 EDCM Distributed Generators (DGs), it is deemed for the purposes of paragraph 17.2 that the customer paid capitalised O&M to be capitalised over a period of 25 years from connection.

## **18. DEMAND SCALING**

- 18.1 Demand scaling is the process by which import charges to EDCM Connectees are set so that the forecast notional recovery from the application of those import charges to EDCM Connectees matches the EDCM demand revenue target.
- 18.2 Demand scaling using the site-specific assets approach involves the following steps:

- Calculating adjusted site-specific shared asset values for each Connectee using network use factors that have been subjected to a cap and collar.
- Allocation of the direct operating cost and network rates elements in the EDCM demand revenue target to individual EDCM Connectees on the basis of adjusted site-specific assets and sole use assets. [a]
- Allocation of the indirect cost element in the EDCM demand revenue target to individual EDCM Connectees on the basis of their consumption at the time of the DNO Party's peak and 50 per cent of Maximum Import Capacity as a p/kVA/day charge. [b]
- Forecasting the notional recoveries from the application of FCP charges to EDCM Connectee. [c]
- Application of residual charges is provided for in accordance with paragraph 18.18 below.

18.3 Adjusted site-specific assets are calculated using network use factors that have been subjected to caps and collars.

18.4 A cap and a collar are calculated for each network level as follows:

- In ascending order, list the network use factors for all EDCM Connectees in all DNO Party areas relating to that network level, excluding all the factors that are either equal to zero or 1, or not used, based on the customer categories of each EDCM Connectee.
- Divide the list into two segments, one that contains factors that are lower than 1, and the other than contains the factors that are higher than 1.
- Take the list segment containing factors that are lower than 1. Starting from the lowest factor in this list segment, calculate the factor at the 15th percentile. This is the collar.
- Take the list segment containing factors higher than 1. Starting from the lowest factor in this segment, calculate the factor at the 85th percentile. This is the cap.

- 18.5 The same cap and collar would apply in all DNO Party areas to network use factors at that network level.
- 18.6 These caps and collars are recalculated triennially, with the three year cycle having been established when caps and collars were calculated when determining 2017/18 charges (in 2015). In years where a recalculation has not been carried out, the values used remain at the most recently calculated values.
- 18.7 Where year t is a charging year for which the caps and collars are being recalculated, the caps and collars calculated and used for years t, t+1 and t+2 will be based on applying the calculation detailed in paragraph 18.4 to the average of network use factors which were used in the calculation of charges applicable to years t-3, t-2 and t-1.
- 18.8 The network use factor caps and collars that are updated in accordance with paragraphs 18.6 and 18.7 will be maintained by the DNO Parties and referenced within the EDCM user manual.
- 18.9 Separate adjusted site-specific asset values per kVA (in £/kVA) is calculated in respect of each network level. The asset value for the network level of connection is based on the Maximum Import Capacity of the EDCM Connectee, and for network levels above on consumption at peak time.

Adjusted site-specific asset value for capacity at level L (£/kVA) =  $NUaL * \text{Average network asset value for capacity at level L (£/kVA)}$

Adjusted site-specific asset value for demand at level L (£/kVA) =  $NUaL * \text{Average network asset value for demand at level L (£/kVA)}$

Where:

$NUaL$  is the adjusted network use factor for that EDCM Connectee at level L after application of the cap and collar.

Average notional asset value for capacity at level L is the voltage level average calculated as described earlier.

Average notional asset value for demand at level L is the voltage level average calculated as described earlier.

- 18.10 The total value of the adjusted site-specific shared assets required to serve each EDCM Connectee is calculated according to the formula:

$$TNAa = NACa + (NADa * (1 - (\text{Hours in super-red for which not a customer} / \text{Annual hours in super-red})) * (\text{Days in year} / (\text{Days in year} - \text{Days for which not a customer})))$$

Where:

TNAa is the total adjusted site-specific network assets in £/kVA required to serve a EDCM Connectee.

NACa is the adjusted site-specific asset value in £/kVA for capacity for that EDCM Connectee aggregated across all levels.

NADa is the adjusted site-specific asset value in £/kVA for demand for that EDCM Connectee aggregated across all levels.

- 18.11 Total adjusted site-specific shared assets for all EDCM demand is the aggregate value (in £) of all adjusted site-specific shared assets for EDCM Connectees. This is calculated by multiplying TNAa by the Maximum Import Capacity (adjusted, if necessary, for Connectees connected for part of the Charging Year), and then aggregating across all EDCM demand.

- 18.12 The direct cost and network rates allocations to individual demand Connectees is determined in the same way as the contributions to the EDCM demand revenue target was calculated, except that adjusted site-specific assets are used.

- 18.13 A single asset based charging rate for network rates is calculated for all EDCM Connectee. This is calculated as follows:

$$\text{Network rates charging rate (per cent)} = \text{EDCM NR contribution} / (\text{Total adjusted site-specific shared assets})$$

Where:

EDCM NR contribution is the sum of the import capacity based network rates contribution from each EDCM Connectee.

Total adjusted site-specific shared assets is the aggregate value (in £) of all adjusted site-specific shared assets for EDCM Connectees.

- 18.14 A single asset based charging rate for direct operating costs is calculated for all EDCM Connectees. This is calculated as follows:

Direct operating costs charging rate (per cent) = EDCM DOC contribution / (Total adjusted site-specific shared assets)

Where:

EDCM DOC contribution is the sum of the import capacity based direct costs contribution from each EDCM Connectee.

Total adjusted site-specific shared assets is the aggregate value (in £) of all adjusted site-specific shared assets for EDCM Connectees.

- 18.15 The charging rates for network rates and direct operating costs are converted into p/kVA/day import capacity based charges for each EDCM Connectee.

Network rates and direct costs charge in p/kVA/day =  $(100 / DC) * TNAa * (NR \text{ rate} + DOC \text{ rate})$

Where:

DC is the number of days in the Charging Year.

TNAa is the total adjusted site-specific assets (£/kVA) for that EDCM Connectee.

NR rate is the network rates charge rate in per cent.

DOC rate is the direct operating costs charge rate in per cent.

- 18.16 A p/kVA/day charging rate for indirect costs for each EDCM Connectee is calculated on the basis of historical demand at the time of the DNO Party's peak and 50 per cent of Maximum Import Capacity of that Connectee.

Indirect cost charging rate in p/kVA/day =  $100 / DC * (\text{Aggregate indirect cost contribution}) / \text{Volume for scaling}$

Where:

DC is the number of days in the Charging Year.

Volume for scaling is calculated as the sum of  $(0.5 + \text{coincidence factor}) * \text{import capacity} * \text{LDNO factor}$  across all EDCM Connectees.

Coincidence factor is calculated as the forecast peak-time consumption in kW divided by Maximum Import Capacity in kVA of that Connectee (based on historical data) multiplied by  $(1 - (\text{Hours in super-red for which not a customer} / \text{Annual hours in super-red})) * (\text{Days in year} / (\text{Days in year} - \text{Days for which not a customer}))$

Import capacity is the Maximum Import Capacity (adjusted if the Connectee is connected for part of the Charging Year) in kVA for that EDCM Connectee.

LDNO factor takes the value 0.5 if the EDCM Connectee is connected to a LDNO's network and 1 otherwise.

Aggregate indirect cost contribution is the sum of the import capacity based and sole use asset based indirect cost contribution from each EDCM Connectee.

- 18.17 The p/kVA/day charging rate for indirect costs is converted into an import capacity based charge for each EDCM Connectee as follows:

Import capacity based INDOC charge in p/kVA/day = Indirect cost charging rate \*  $(0.5 + \text{coincidence factor}) * \text{LDNO factor}$

Where:

Indirect cost charging rate is the Distribution System-wide p/kVA/day rate calculated as described in the previous paragraph.

Coincidence factor is calculated as the forecast peak-time consumption in kW divided by Maximum Import Capacity in kVA of that Connectee (based on historical data) multiplied by  $(1 - (\text{Hours in super-red for which not a customer} / \text{Annual hours in super-red})) * (\text{Days in year} / (\text{Days in year} - \text{Days for which not a customer}))$

LDNO factor takes the value 0.5 if the EDCM Connectee is connected to a LDNO's network and 1 otherwise.

- 18.18 Residual charges will be allocated as follows:

- The difference between the EDCM demand revenue target and the sum of a, b and c under Paragraph 18.2 above will be apportioned to specific charging bands as set out in paragraph 2.4 of Schedule 32, according to the total forecast metered import consumption for the charging band proportionate to the total forecast metered import consumption for all Final Demand Sites which are EHV Designated Properties.
- The allocated proportion of the residual value to each charging band will then be divided equally among all Final Demand Sites within that charging band, resulting in the same level of residual fixed charge for each such site.
- Residual charges for each Final Demand Site will be applied as a fixed charge adder (p/Final Demand Site/day) calculated as follows: the revenue surplus or shortfall (in pence) to be returned or recovered for the band that the Final Demand Site is in; divided by the total number of Final Demand Sites in that band; divided by days in the charging year.
- For any DNO Party, if the count of Final Demand Sites in any given charging band is less than two in the charging year for which tariffs are being determined, the residual fixed charge for that band will be calculated as set out in accordance with the bullet points above, but the total forecast metered import consumption and total count of Final Demand Sites in that band will be combined with the equivalent information for the band above that band. If the band in question is the highest band, then it will be combined with the equivalent information for the band below that band. The residual fixed charge should therefore be the same for all Final Demand Sites in the combined bands. There must be no single or combined band with less than two Final Demand Sites within that band. A Final Demand Site connected during the year will be counted as a fraction based on the proportion of the year for which the site was connected.
- There are eight possible combinations for grouping non-domestic charging bands under the above bullet point. Where there are less than two Final Demand Sites in a band the grouping of the bands under the above bullet point will be in accordance with the preference order given in the table below.

Preference order for band grouping combinations	Band 1	Band 2	Band 3	Band 4
First	1	2	3	4
Second	1 + 2		3	4
Third	1	2 + 3		4
Fourth	1	2	3 + 4	
Fifth	1 + 2		3 + 4	
Sixth	1 + 2 + 3			4
Seventh	1	2 + 3 + 4		
Eighth	1 + 2 + 3 + 4			

- In all cases, residual fixed charge component will be added to the fixed charge component to create a single fixed charge.

18.19 Not used.

18.20 Not used.

18.21 Not used.

18.21A The fixed adder for a Non-Final Demand Site shall be zero.

## **19. APPLICATION OF EDCM DEMAND FOR EDCM CONNECTEES**

19.1 The tariff application rules for the EDCM are the same as for the CDCM wherever possible. Each component of each tariff is rounded to the nearest value with no more than three decimal places in the case of unit rates expressed in p/kWh, and with no more than two decimal places in the case of fixed and capacity charges expressed in p/day and p/kVA/day respectively.

19.2 The part of EDCM portfolio tariffs (for LDNO networks and Distribution Licence exempt networks) that is based on CDCM tariffs will be billed like CDCM tariffs.

19.3 Final EDCM demand charges will have:

1. an import fixed charge (in p/day)
2. an import capacity charge (in p/kVA/day)
3. an import super-red unit rate charge (in p/kWh)
4. an exceeded import capacity charge (in p/kVA/day).

19.4 The import fixed charge for each EDCM Connectee in p/day would be calculated as follows:

EDCM import fixed charge (p/day) = [FCP fixed charge on sole use assets in p/day] + [residual fixed charge in p/day].

19.5 The final EDCM import capacity charge for each EDCM Connectee in p/kVA/day would be calculated as follows:

EDCM import capacity charge (p/kVA/day) = [FCP p/kVA/day capacity charge] + [Transmission exit charge p/kVA/day] + [Network rates and direct costs charge in p/kVA/day] + [Indirect costs charge in p/kVA/day]

19.6 The final EDCM super-red unit rate in p/kWh is the FCP super-red unit rate as calculated as described earlier in this document.

19.7 If the EDCM import capacity charge (p/kVA/day) calculated above is negative and the Connectee's average kW/kVA (adjusted for part year) is not equal to zero, the final EDCM super-red unit rate is adjusted as follows:

Adjusted FCP super-red unit rate in p/kWh = [FCP super-red rate in p/kWh] + (([EDCM import capacity charge (p/kVA/day)] \* ([Days in the Charging Year] – [Days for which not a customer]) / [Average kW/kVA] / ([hours in the super-red time band] - [Hours in super-red for which not a customer]))

19.8 Finally, any remaining negative import super-red unit rates or import capacity charges are set to zero.

19.9 Final EDCM export charges will have:

1. An export fixed charge on sole use assets (in p/day)
2. An export capacity charge (in p/kVA/day), which might include transmission exit credits to qualifying generators.

3. An export super-red unit rate (in p/kWh)
  4. An exceeded export capacity charge (in p/kVA/day)
- 19.10 The export capacity charge (in p/kVA/day) is applied to the Chargeable Export Capacity of EDCM Connectees.
- 19.11 The export super-red unit rate (in p/kWh) is applied to active power units exported during the DNO Party's super-red time band.

## **20. EXCEEDED CAPACITY CHARGES**

- 20.1 Where a Connectee uses additional capacity over and above the Maximum Import Capacity or Maximum Export Capacity without authorisation, the excess is classed as exceeded capacity.
- 20.2 For the purposes of determining capacity used, the following formula is used for each half hour:

$$\text{Import capacity used} = 2 * (\text{SQRT}(\text{AI}^2 + \text{MAX}(\text{RI}, \text{RE})^2))$$

Where:

AI = Import consumption in kWh

RI = Reactive import in kVAh

RE = Reactive export in kVAh

$$\text{Export capacity used} = 2 * (\text{SQRT}(\text{AE}^2 + \text{MAX}(\text{RI}, \text{RE})^2))$$

Where:

AE = Export production in kWh

RI = Reactive import in kVAh

RE = Reactive export in kVAh

- 20.3 For the purposes of calculating exceeded capacity for import charges, any reactive flows during half hours when there is no active power import would not be taken into account.
- 20.4 For the purposes of calculating exceeded capacity for export charges, any reactive flows during half hours when there is no active power export will not be taken into account.
- 20.5 Any reactive flows associated with a site which operates subject to grid code requirements for generation or sites providing voltage control at the request of the DNO Party would not be taken into account when calculating import or export capacity used.
- 20.6 For Connectees other than those that have an agreement with the DNO, the terms of which require them, for the purposes of P2/6 compliance, to export power during supergrid transformer (SGT) outage conditions, the exceeded portion of the export capacity is charged at the same rate as the capacity that is within the Maximum Export Capacity. This is charged for the duration of the month in which the breach occurs.
- 20.7 For Connectees other than those with DSM agreements, the exceeded portion of the import capacity is charged at the same rate as the capacity that is within the Maximum Import Capacity. This is charged for the duration of the month in which the breach occurs.
- 20.8 Sites subject to DSM arrangements would normally pay the DSM-adjusted capacity charge for capacity usage up to their Maximum Import Capacities.
- 20.9 If sites with DSM agreements were to exceed their maximum import capacities, the exceeded portion of the capacity will be charged at a different rate. This will be charged for the duration of the month in which the breach occurs. This charge for exceeded capacity (in p/kVA/day) would be determined as follows;

$$\begin{aligned}
 &[\text{Exceeded capacity charge in p/kVA/day}] = [\text{Import capacity charge p/kVA/day}] + \\
 &(((\text{FCP capacity charge p/kVA/day}] + ([\text{FCP super-red rate p/kWh}] * [\text{Average} \\
 &\text{kW/kVA adjusted for part year}] * [\text{number of super-red hours connected}] / ([\text{days in} \\
 &\text{Charging Year}] - [\text{Days for which not a customer}]))) * (1 - ([\text{chargeable capacity}] / \\
 &[\text{Maximum Import Capacity}]))
 \end{aligned}$$

Where:

The FCP super-red unit rate and FCP capacity charges in the equation above are the charges before any adjustments for DSM have been made.

## 21. APPLICATION OF EDCM IMPORT CHARGE COMPONENTS

21.1 Table 21.1 summarises the method of application of import charge components.

**Table 21.1 Application of EDCM import charge components**

Tariff component	Unit	Application
Import fixed charge	p/day	Applied as a fixed charge.
Import capacity charge	p/kVA/day	Applied to the Maximum Import Capacity.
Exceeded import capacity charge	p/kVA/day	Applied to exceeded capacity for the duration of the month in which the breach occurs (except for sites which operates subject to grid code requirements for generation)
Import super-red unit rate	p/kWh	Applied to active power units consumed during the DNO Party's super-red time band.

21.2 Table 21.2 summarises the method of application of export charge components.

**Table 21.2 Application of EDCM export charge components**

Tariff component	Unit	Application
Export fixed charge	p/day	Applied as a fixed charge.
Export capacity charge	p/kVA/day	Applied to the Chargeable Export Capacity.
Exceeded export capacity charge	p/kVA/day	Applied to exceeded capacity for the duration of the month in which the breach

		occurs (except for sites which operates subject to grid code requirements for generation)
Export super-red unit rate	p/kWh	Applied to active power units exported during the DNO Party's super-red time band.

## **22. CHARGES FOR NEW CONNECTEES**

- 22.1 New Connectees could connect at any time between the publication of EDCM charges for the new Charging Year and the end of that Charging Year.
- 22.2 If the connection of such Connectees had been anticipated before the publication of charges, the DNO Party would have included forecast data relating to the new Connectee in both the power flow model and the EDCM tariff model. The resulting tariff is applied to the new Connectee, on a pro-rata basis if the price is produced during the Charging Year.
- 22.3 If prices need to be produced for new connections that had not been anticipated at the time of calculating EDCM charges for that Charging Year, the DNO Party will:
- Seek indicative load profile information from the new Connectee, failing that, make a reasonable estimate;
- Run the power flow model after including the new Connectee to produce a full set of charges 1 and 2, including for the new Connectee;
- Include the new Connectee's details, including marginal charges from (a) in the EDCM tariff model, to produce a full set of new charges;
- Use the tariff relating to the new Connectee to calculate charges; and
- Charges relating to the current year for existing Connectees would not change as a result.
- 22.4 If a Connectee were to change their maximum import or export capacity at any time between the publication of EDCM charges for the Charging Year and the end of the

Charging Year, the published tariff rates would continue to apply for the duration of the Charging Year.

### **23. DNO TO DNO CHARGES**

- 23.1 In the case of DNO Party to DNO Party interconnections, the interconnections are categorised into four types:
- (a) The interconnector between the DNO Parties is normally closed (active), and there is an identifiable benefit from the existence of the interconnection to one DNO Party only. The other DNO Party does not benefit from the interconnection.
  - (b) The interconnector is normally closed (active), and there is either an identifiable benefit to both DNO Parties, or no clear benefit to either DNO Party.
  - (c) The interconnector is normally open, and the interconnection exists only to provide backup under certain conditions to either DNO Party.
  - (d) All other interconnections between DNO Parties.
- 23.2 In all cases of type (a), the benefitting DNO Party will be treated as being equivalent to an EDCM Connectee connected to the other DNO Party's network. The DNO Party providing the benefit will calculate and apply EDCM import charges, except charges for sole use assets, as applicable to the other DNO Party. Export charges or credits will not apply.
- 23.3 In the case of type (b) interconnections, each DNO Party will treat the other as an EDCM Connectee. Normal EDCM import charges, except charges for sole use assets, will apply. Export charges or credits will not apply.
- 23.4 Type (c) interconnections are typically covered by special arrangements between DNO Parties. Use of system charges are agreed between DNO Parties and applied outside the EDCM model.
- 23.5 In every other case, each DNO Party applies import charges to the other as a normal EDCM Connectee, as with type (b) interconnections.

## **24. LDNO CHARGING**

- 24.1 LDNOs with Distribution Systems that serve Connectees that fall within the scope of the CDCM would have their charges based on standard discount percentages applied to the CDCM all-the-way end user charges.

A LDNO with a Distribution System that qualifies as a CDCM “Designated Property” according to the definition set out in condition 13A.6 of the Distribution Licence is eligible for portfolio discounts calculated using the price control disaggregation model provided for under Schedule 29, with any subsequent adjustment applied in respect of the DNO Party's Supplier of Last Resort and Eligible Bad Debt pass-through costs as described in paragraphs 100 to 104 of the CDCM.

A LDNO with a Distribution System that qualifies as an EDCM “Designated EHV Property” according to the definition set out in condition 13B.6 of the Distribution Licence is eligible for discounts calculated using the price control disaggregation model provided for under Schedule 29, with any subsequent adjustment applied in respect of the DNO Party's Supplier of Last Resort and Eligible Bad Debt pass-through costs as described in paragraphs 100 to 104 of the CDCM.

- 24.2 A LDNO with a Distribution System that qualifies as an EDCM “Designated EHV Property” could itself have Connectees who would fall under the scope of the EDCM. Since the EDCM is a locational charging method, the host DNO Party would calculate EDCM charges at the DNO Party’s boundary for each EDCM-like Connectee on the LDNO’s Distribution System. No discounts are calculated for such EDCM Connectees as the DNO Party’s charges are based only on the specific site’s equivalent use of the DNO Party’s Distribution System.

## **25. CALCULATION OF LDNO DISCOUNTS**

- 25.1 The discount percentages are determined in accordance with Schedule 29, which is deemed to form part of this EDCM (as if it were set out therein).
- 25.2 In each case, the discount is applied to all CDCM tariff components. Discount percentages are capped to 100 per cent.

25.3 Supplier of Last Resort pass-through costs are allocated by applying a fixed charge adder (p/day) to the following customer groups, as calculated under paragraph 102 of the CDCM:

- LDNO HVplus: Domestic Aggregated or CT;
- LDNO EHV: Domestic Aggregated or CT;
- LDNO 132kV/EHV: Domestic Aggregated or CT;
- LDNO 132kV: Domestic Aggregated or CT;
- LDNO 0000: Domestic Aggregated or CT.

25.4 Eligible Bad Debt pass-through costs are allocated by applying a fixed charge adder (p/day) to all metered demand tariffs excluding ‘related MPAN’ tariffs, as calculated under paragraph 103 of the CDCM.

25.5 Not used.

25.6 Not used.

25.7 Not used.

25.8 Not used.

25.9 Not used.

25.10 Not used.

25.11 Not used.

25.12 Not used.

25.13 Not used.

25.14 Not used.

25.15 Not used.

25.16 Not used.

25.17 Not used

25.18 Not used.

25.19 Not used.

## **26. PORTFOLIO EDCM TARIFFS FOR CONNECTEES IN THE EDCM**

26.1 For Connectees on a LDNO's Distribution System that would be covered by the EDCM if they were on the DNO Party's Distribution System, the EDCM is applied to calculate a portfolio EDCM charge/credit for each such Connectee.

26.2 These EDCM portfolio charges would be calculated as if each EDCM Connectee on the LDNO's Distribution System were notionally connected at the boundary between the DNO Party and the LDNO; except for LDNO UMS tariffs, which are charged by reference to the voltage of the Points of Connection that provide the majority of the energised domestic connections for the LDNO in the GSP Group (or, where there is no such majority, on such other reasonable basis as the DNO Party determines). Both EDCM import and export charges will apply.

26.3 For the purposes of calculating the boundary-equivalent portfolio EDCM tariffs, each EDCM Connectee on the LDNO's Distribution System would be assigned the demand Connectee category determined by reference to that LDNO Distribution System's Point of Common Coupling. The demand Connectee category is assigned as per Table 15.6.

26.4 Such Connectees would attract charges (credits) in respect of any reinforcements caused (avoided) on the DNO Party's Distribution System only, i.e. any network Branches that are on the LDNO's Distribution System would be attributed a zero FCP charge/credit.

26.5 The setting of final charges to Embedded Designated EHV Properties including the calculation of charges for assets used on the LDNO's Distribution System will be established by the LDNO.

26.6 All EDCM charges would be calculated using "boundary equivalent" data provided by the LDNO to the host DNO Party for each Embedded Designated EHV Property. For the purposes of the EDCM, boundary equivalent data should be what the LDNO has

allowed for at the DNO Party - LDNO boundary, for each EDCM Connectee, after taking into consideration the diversity and losses within the LDNO's Distribution System. Data relating to CDCM end users must be considered for the purposes of calculating boundary equivalent data in order to cater for the effect of diversity and losses.

- 26.7 The EDCM will include in the charges for Embedded Designated EHV Properties a fixed charge relating to any assets on the DNO Party's Distribution System that are for the sole use of a LDNO's Distribution System. The assets on the DNO Party's network that are for the sole use of a LDNO Distribution System are defined as the assets in which only consumption or output associated with Embedded customers on the LDNO Distribution System can directly alter the power flow in the asset, taking into consideration all possible credible running arrangements, i.e. all assets between the asset ownership boundary and the LDNO Distribution System's Point of Common Coupling are considered as sole use assets. These fixed charges would be calculated in the same way as it would be for EDCM Connectees connected directly to the host DNO Party's Distribution System.
- 26.8 In calculating charges for assets on the DNO Party's Distribution System that are for the sole use of a LDNO's Distribution System, DNO Parties will charge only for the proportion of sole use assets deemed to be used by Embedded Designated EHV Properties. This proportion will be calculated, in respect of each Embedded Designated EHV Properties, as the ratio of the boundary equivalent capacity of that Connectee to the capacity at the LDNO - DNO Party boundary.
- 26.9 If there are no Embedded Designated EHV Properties on the LDNO's Distribution System, no sole use asset charges would apply.
- 26.10 Demand scaling would be applied as normal to any EDCM portfolio tariff in respect of an EDCM Connectee. For the purposes of scaling, all EDCM Connectees connected to the LDNO's Distribution System will be treated as notional EDCM Connectees connected to the DNO Party's Distribution System with a Point of Common Coupling at the LDNO Distribution System's Point of Common Coupling.
- 26.11 For EDCM Connectees connected to the LDNO's Distribution System, the capacity-based charge for the DNO Party's indirect costs and 20% of the residual fixed charge

for the EDCM Connectee, would be scaled down by a factor of 50 per cent, however, the scaling down will not apply where the residual revenue is negative.

## **27. OFFSHORE NETWORKS CHARGING**

- 27.1 The DNO Party will treat offshore networks connected to the DNO Party as if they were EDCM Connectees.
- 27.2 The DNO Party will apply the EDCM to calculate an import and export charge based on capacity at the boundary and power flow data metered at the boundary.
- 27.3 Any sole use assets specific to the offshore network are charged as a p/day sole use asset charge calculated as applicable to a normal EDCM Connectee.
- 27.4 Demand scaling will also be applied.

## **28. DNO PARTY TO UNLICENSED NETWORKS**

- 28.1 Unlicensed networks have a choice. If they are part of the Total System under the Balancing and Settlement Code with the network open to supply competition, and if they are party to the DCUSA, and have accepted the obligations to provide the necessary data, they can, if they wish, be treated as LDNOs.
- 28.2 Otherwise, the DNO Party applies the EDCM to calculate an import and export charge based on capacity and power flow data metered at the boundary. Any sole use assets specific to the unlicensed network are charged as a p/day sole use asset charge calculated as applicable to a normal EDCM Connectee.

## **29. DERIVATION OF 'NETWORK USE FACTORS'**

### **Step 1:**

- 29.1 Powerflow analysis is used to determine the change in powerflow in each Branch (in MW) that is caused by a change in load (in MW) at each node in the EHV network model, that represents either EDCM demand or CDCM demand at the EHV/HV boundary.

29.2 In essence, a change in load of X MW is applied at the node under consideration and changes in powerflow in each network Branch are identified. If the change in powerflow in a particular Branch is Y MW, as a result in the change in load at the node under consideration, then the ‘Change In Branch Flow per Change In Demand’ is given by:-

$$\text{Abs (Y/X)} \quad (\text{MW Branch flow per MW of demand at node})$$

29.3 The effects of a change in demand at each node, upon the powerflows in Branches, are evaluated for each node in turn.

29.4 The method of evaluating the ‘Change in Branch Flow per Change in Demand’ shall be the Incremental Method, described below:

### **30. INCREMENTAL METHOD:**

30.1 Establish the ‘base case’ powerflow in each Branch using a network model constructed with demand data used to represent the Maximum Demand Scenario analysed in the marginal cost calculation, using Maximum Demand Data that represents the regulatory year that use of system charges are being calculated for.

30.2 Apply a 0.1MW (at 0.95 lagging p.f.) increment to each node, in turn, in the EHV network model (at nodes that represent either an EDCM Connectee or CDCM demand at the EHV/HV boundary) and identify the change in powerflow (in MW) in all Branches where the change exceeds both 1kVA and 0.01% of the ‘base case’ powerflow in the Branch. The change in Branch flow corresponding to a 0.1MW increment at a node can be evaluated by actual application of an increment to the network model, or through the use of sensitivity coefficients. Prior to the application of the increment all the transformer tap positions, distributed generation outputs and switched shunt values are fixed to the values determined in the ‘base case’ powerflow to prevent change in their values when analysing the power flows with the increment applied.

30.3 This calculation is performed upon the Authorised Network Model and only considers normal running arrangements.

#### **Step 2:**

30.4 The ‘MW usage’ of each Branch by a given nodal demand is determined by multiplying the relevant value of ‘Change In Branch Flow per Change In Demand’ (derived in step 1) by the demand at the node (MW) as used in the Maximum Demand Scenario for the marginal cost calculation, using the Maximum Demand Data that represents the regulatory year that use of system charges are being calculated for. This will always be a positive quantity.

**Step 3:**

30.5 For each Branch, the ‘total MW usage’ of the Branch by all nodal demands is determined by summing the ‘MW usage of the Branch’ by each node (as determined in step 2).

**Step 4:**

30.6 Each nodal demand’s proportionate usage of a Branch is determined using the equation below:

$$\text{Alloc (£/year)} = ([\text{MW usage}] / [\text{Total MW usage}]) * (\text{Abs} [\text{Max contingency flow}] / [\text{Rating}]) * \text{AMEAV}$$

If the Branch is “generation-dominated”, or  $(2 * \text{Abs} [\text{Base flow load}] \leq \text{Abs} ([\text{Base flow}] - [\text{Base flow load}]))$ , then use:

$$\text{Alloc (£/year)} = ([\text{MW usage}] / [\text{Total MW usage}]) * (\text{Abs} [\text{Max contingency flow}] / [\text{Rating}]) * \text{Abs} ([\text{Base flow load}] / [\text{Base flow}]) * \text{AMEAV}$$

Where:

- Alloc is the allocation of the AMEAV of the asset to a demand user in £/year
- MW usage is the absolute value of the “MW usage” of the asset attributable to that demand user (expressed in MW)
- Total MW usage is the sum of the absolute values of the “MW usage” of all demand users of that asset (expressed in MW)

- Max contingency flow is the maximum post-contingent flow through the asset in MVA. The maximum post-contingency asset flows may be extracted from the ‘locational’ analyses.
- Rating is the unadjusted rated capacity of the asset in MVA
- Base flow load is the algebraic sum of power flows through the Branch due to demand only in MW.
- Base flow is the aggregate power flow through the Branch under normal network operation in MW.
- AMEAV is the annualised modern equivalent asset value in £/year of that asset.
- The ratio ( $[\text{Max contingency flow}] / [\text{Rating}]$ ) is called the asset utilisation factor and it is capped at 1.

The quantity ( $\text{Abs} [\text{Max contingency flow}] / [\text{Rating}] * \text{Abs} ([\text{Base flow load}] / [\text{Base flow}])$ ) is called the load utilisation factor.

- 30.7 Sole use assets are not to be included in the calculation of the MEAV of the Branches and consequently some Branches may have an MEAV of zero.

#### **Step 5:**

- 30.8 For each node, the £/annum ‘usage’ of Branches (calculated in Step 4) of the same voltage level, by the demand at the node, are summated to create a total £/annum for each voltage level for the nodal demand. The considered voltage levels correspond to those used in the CDCM and include voltage levels that represent transformation between two voltages. These voltage levels are ‘132kV’, ‘132kV/EHV’, ‘EHV’, ‘EHV/HV’ and ‘132kV/HV’.
- 30.9 For each node where EDCM demand is present, the total £/annum ‘usage’ of Branches of each voltage level, for the node, is divided by the demand at the node (in kW), as used in the Maximum Demand Scenario, to create a £/kW/annum total usage of Branches at each voltage level by the particular node. This shall be the numerator in the network use factor, for a particular voltage level, for the EDCM demand node.

- 30.10 For all nodes where CDCM demand is present, and the CDCM demand is considered to be ‘dominant’ at the node ( CDCM demand shall be considered to be ‘dominant’ where the DNO Party estimates that the maximum demand associated with all CDCM demand at the node exceeds the maximum demand associated with all EDCM demand at the node), the £/annum ‘usages’ of Branches at each voltage level (calculated in Step 4) are summated to create a total £/annum ‘usage’ for all CDCM dominated nodes. The CDCM demand ‘using’ each voltage level is determined by summing the nodal demands of all CDCM dominated nodes that have non zero £/annum ‘usages’ at the particular voltage level. The average £/kW/annum network usage by CDCM dominated nodes is derived for each voltage level by dividing the total £/annum usage (at the voltage level by CDCM dominated nodes) by the total CDCM demand ‘using’ the voltage level. This provides the denominators used for the network use factors.
- 30.11 The network use factor, at each voltage level, for each node where EDCM demand is present therefore is the £/kW/annum for the nodal demand at the appropriate voltage level, divided by the corresponding average £/kW/annum for the same voltage level determined for CDCM dominated nodes.

**SCHEDULE 17 – EHV CHARGING METHODOLOGY (FCP MODEL)****ANNEX 1 – IMPLEMENTATION GUIDE****1. SCOPE**

- 1.1 This Annex describes the definitions, input data and power flow analyses required for modelling the DNO Party's Distribution System to enable the FCP methodology to be implemented as set out in the EDCM. The output data are also described.

**2. POWER SYSTEMS ANALYSIS**

- 2.1 The DNO Parties routinely analyse their Distribution Systems using power system analysis tools to identify where limitations exist on the network; this information is used to plan reinforcements.
- 2.2 Planning of a Distribution System (to satisfy the requirements of the Act and the Distribution Licences) using a power system analysis tool requires the development of a network model which represents the actual Distribution System and the application of demand data that represent the demands that the Distribution System will be required to deliver whilst satisfying the nationally defined security standard, ER P2/6.
- 2.3 The aim of using power flow analysis for pricing purposes is to replicate the reinforcement assessment process and determine the costs of future network reinforcements in order to generate cost-reflective incremental charges.
- 2.4 The DNO Parties use a variety of software tools to model their respective Distribution Systems for the purposes of operating and planning Distribution Systems. The Authority and the DNO Parties have agreed that it is not appropriate to prescribe which software tool is used for the analysis of the Distribution System, as it is for each DNO Party to satisfy itself that it is using the appropriate tools for planning and operation of its Distribution System.
- 2.5 The following sections describe the definitions, input data and the power flow analyses required to model the Distribution System for pricing purposes. The calculation of reinforcement costs and the main outputs are discussed.

### 3. DEFINITIONS

**In this Schedule 17, unless the context otherwise requires, the expressions below shall have the meanings set out below.**

<b>Term</b>	<b>Definition</b>
<b>Active Power</b>	The product of the voltage, current and cosine of the phase angle between them, measured in watts.
<b>Allowed Revenue</b>	The amount of revenue that the DNO Party can earn on its regulated business in accordance the special conditions within the DNO Party's Distribution Licence.
<b>Authorised Network Model</b>	The model that represents the DNO Party's entire EHV network (from the GSP level down to and including the HV busbar at the EHV/HV transformation level), as described in Paragraph 2.3 and section 4 of this Annex 1.
<b>Branch</b>	<p>A representation of an asset, collection of assets or part of an asset of the DNO Party's EHV network through which Active Power flows as a consequence of supply to or export from a Connectee or busbar on the DNO Party's HV or EHV networks. A Branch must only be connected between two Nodes. A Branch should conform to the following:</p> <ul style="list-style-type: none"> <li>• there can be more than one Branch between the same two Nodes;</li> <li>• a three winding transformer may be represented by three Branches (one Branch for each of the windings) configured in a star formation;</li> <li>• the Active Power flowing out of one end of a Branch should equal the Active Power flowing into the other end of the Branch less any losses within the Branch;</li> </ul>

- shunt reactors and capacitors are not Branches;
- earthing transformers, resistors and reactors are not Branches;  
and
- a Branch may constitute a collection of assets e.g. a circuit constituting overhead lines and cables. When combining assets into a Branch, there is a need to consider the reinforcement solution for the Branch in the next stages for the Use of System Charging calculation.

<b>Branch Rating</b>	The Branch Ratings selected for the Authorised Network Model should be derived by appropriate consideration of the time of day / season / general nature of load profile (i.e. continuous, cyclic, etc.) represented within the model.
<b>Bulk Supply Point (BSP)</b>	A supply point on the DNO Party's Distribution System representing an EHV/EHV transformation level e.g. 132/33kV.
<b>Charging Year</b>	The financial year (12 month period ending on a 31st March) for which charges and credits are being calculated.
<b>Circuit</b>	The part of a Distribution System between two or more circuit breakers, switches and/or fuses inclusive. For the avoidance of doubt a circuit can contain a number of Branches and Nodes. A Circuit may include transformers, reactors, cables and overhead lines. Busbars are not considered as Circuits.
<b>Circuit Branch</b>	A categorisation used in the derivation of Branch reinforcement costs for Branches that represent an interconnection (or part of an interconnection) between substations and which operate at a single voltage level.
<b>Connection Node</b>	A Node which is a point of connection to one of the following: <ul style="list-style-type: none"> <li>• an Entry Point or the Sole Use Assets connecting the Entry Point; or</li> </ul>

- an Exit Point or the Sole Use Assets connecting the Exit Point;  
or
- the DNO Party's HV network; or
- a Distribution System of another DNO Party or IDNO Party.

<b>Contingency Analysis</b>	The analysis to determine the effect on power flows for the Authorised Network Model under N-1 and where necessary, N-2 contingencies.
<b>Diversity Allowance</b>	The extent, expressed as a percentage, to which the sum of the maximum load across all assets in the modelled network level is expected to exceed the simultaneous maximum load for the network level as a whole.
<b>Diversity Factor</b>	A scaling factor calculated as the ratio of the maximum demand observed at a given location on the network and the aggregate of the individual maximum demands observed at multiple locations connected downstream (i.e. further from source) of the given location, taking account of losses. Such factors provide a means of recognising that the maximum demands observed at individual locations (e.g. substations at a given voltage level) on a section of network may not be coincident. Details of the calculation of Diversity Factors are set out in section 5.9 (Diversity Factors) of Annex 1.
<b>EDCM</b>	has the meaning given to that expression in Paragraph 1
<b>EDCM Connectee</b>	means a Connectee whose Connected Installation is a Designated EHV Property as defined in Standard Conditions 50A.11 and 13B.6 of the DNO Party's Distribution Licence.
<b>EDCM Customer</b>	means a Customer whose Customer Installation is a Designated EHV Property as defined in Standard Conditions 50A.11 and 13B.6 of the DNO Party's Distribution Licence.

<b>EDCM Generation</b>	means a Generator Installation that is a Designated EHV Property as defined in Standard Conditions 50A.11 and 13B.6 of the DNO Party's Distribution Licence.
<b>EHV</b>	Extra High Voltage.
<b>Eligible Bad Debt</b>	means any bad debts with respect to Use of System Charges that the DNO Party can recover in accordance with the DNO Party's Distribution Licence. For the avoidance of doubt, this definition includes the DNO Party's bad debt and bad debt which the DNO Party is recovering on behalf of LDNOs.
<b>Embedded</b>	means connected to a LDNO's Distribution System.
<b>ER P2/6</b>	Energy Network Association's Engineering Recommendation P2/6 which is the planning standard for security of supply to be used by the DNO Parties.
<b>ETR 130</b>	Energy Network Association's Engineering Technical Report 130 which is the Application Guide for assessing the capacity of Distribution Systems to which Generation Installations are connected.
<b>Extra High Voltage (EHV)</b>	Refers to voltages operating on the Authorised Network Model at 22kV or higher.
<b>Forecast Business Plan Questionnaire or FB PQ</b>	means the questionnaire that the DNO Party is required to submit under the Regulatory Instructions and Guidance issued by the Authority under the DNO Party's Distribution Licence.
<b>FCP</b>	Has the meaning given to that expression in Paragraph 2.1
<b>Grid Supply Point (GSP)</b>	A point of supply from the National Electricity Transmission System to the DNO Party's Distribution System.
<b>High Voltage (HV)</b>	Refers to voltages operating on the Authorised Network Model above 1000 volts but lower than 22kV.

<b>kV</b>	Kilovolt (1,000 Volts): a unit of voltage.
<b>kVA</b>	Kilo Volt Ampere: a unit of network capacity.
<b>kVAr</b>	Kilo Volt Ampere reactive: a unit of reactive power flow.  The network capacity used by a flow of A kW and B kVAr is $\text{SQRT}(A^2+B^2)$ kVA.
<b>kVArh</b>	kVA reactive hour: a unit of total reactive power flow over a period of time. Reactive power meters usually register kVArh.
<b>kW</b>	Kilowatt (1,000 Watts): a unit of power flow.
<b>kWh</b>	Kilowatt hour: a unit of energy. Meters usually register kWh.
<b>LDNO</b>	refers to a licensed distribution network operator, meaning an IDNO Party or a DNO Party operating an electricity distribution system outside of its Distribution Services Area.
<b>Long Term Development Statement (LTDS)</b>	The Long Term Development Statement as detailed by Licence Condition 25 of the Distribution Licences.
<b>LV</b>	Nominal voltages of less than 1kV.
<b>Maximum Demand Data</b>	The Network Demand Data that is applied to the demand (load) analysis for N-1 contingency testing. The construction of Maximum Demand Data is described in section 5.35 ( <b>Maximum Demand Data for Demand (Load) Analysis</b> ) of Annex 1.
<b>Maintenance Demand Data</b>	The Network Demand Data that is applied to the demand (load) analysis for N-2 contingency testing (by supposition, this would consider N-1 contingencies). The construction of Maintenance Demand Data is described in section 5.41 ( <b>Maintenance Demand Data for Demand (Load) Analysis</b> ) of Annex 1.
<b>MVA</b>	Mega Volt Ampere (1,000 kVA): a unit of network capacity.

<b>MW</b>	Megawatt (1,000 kW): a unit of power flow.
<b>MWh</b>	Megawatt hour (1,000 kWh): a unit of energy. Energy trading is usually conducted in MWh.
<b>N-1 Contingency</b>	An N-1 Contingency considers an N-1 Event occurring on the Authorised Network Model and models the consequential network actions and where appropriate constraints on customer demands. This is used to ensure that the resultant flows in Branches that remain in service are within rated capacity.
<b>N-1 Event</b>	An N-1 Event is a First Circuit Outage (FCO) as explained in ER P2/6. It signifies a fault or arranged outage on the network which would result in a section of the network defined by the relevant protection scheme to sectionalise and isolate the faulty section, or isolates the section to be worked on for maintenance, resulting in zero power flow in the affected network. N-1 Events should consider an outage of a complete Circuit and only consider faults or arranged outages occurring with the network initially running under Normal Running Arrangements.
<b>N-2 Contingency</b>	An N-2 Contingency considers an N-2 Event occurring on the Authorised Network Model and models the consequential network actions and where appropriate constraints on customer demands. This is used to ensure that the resultant flows in Branches that remain in service are within rated capacity.
<b>N-2 Event</b>	An N-2 Event is a Second Circuit Outage (SCO) as explained in ER P2/6. It signifies the occurrence of a fault on the network at the same time as a planned outage which would result in a section of the network defined by the relevant protection scheme to sectionalise and isolate the faulty section. As N-2 Events are considered to have occurred at the same time as a planned outage, they are confined to the maintenance period, as designated by the

DNO Party. Maintenance Demand Data is used when considering N-2 Events.

<b>National Electricity Transmission System</b>	Has the meaning given to that expression in the CUSC
<b>Negative Load Injection</b>	A Negative Load Injection is a negative value of load calculated and applied to a source substation within the network model to represent the effects of diversity between associated downstream demands upon the actual demand observed at the source substation.
<b>Net Diversity Factor</b>	A scaling factor that represents the diversity between the maximum demands observed at substations at different levels of a network, which may be derived by multiplying Diversity Factors representing the diversity between interim levels.
<b>network</b>	This is a reference to the DNO Party's Distribution System, or to a particular part of that Distribution System.
<b>Network Demand Data</b>	This is the load and generation which is used to populate the Authorised Network Model. Network Demand Data is constructed of Network Demand Data (Load) and Network Demand Data (Generation).
<b>Network Demand Data (Generation)</b>	Generation export applied within the Authorised Network Model at Nodes representing the Entry Point for each EHV connected customer with an agreed Maximum Export Capacity factored according to ER P2/6, where appropriate.
<b>Network Demand Data (Load)</b>	The load applied within the Authorised Network Model at Nodes representing the Exit Point for each EHV customer and the lower voltage busbars at substations representing transformation points between Network Groups or EHV/HV substations.
<b>Network Group</b>	This is one of the parts of the Authorised Network Model described in Paragraph 2.7 and section 6 (Network Groups) of Annex 1.

<b>network level</b>	The network is modelled as a stack of circuit and transformation levels between supplies at LV and the National Electricity Transmission System. A network level is any circuit or transformation level in that stack. An additional network level is used for transmission exit.
<b>Node</b>	<p>A representation of a point on the DNO Party's EHV network that is a point of connection between a Branch and one or more of the following:</p> <ul style="list-style-type: none"> <li>• another Branch; or</li> <li>• an Entry Point or the Sole Use Assets connecting the Entry Point; or</li> <li>• an Exit Point or the Sole Use Assets connecting the Exit Point; or</li> <li>• the DNO Party's HV network; or</li> <li>• the Distribution System of another DNO Party or IDNO Party; or</li> <li>• the National Electricity Transmission System.</li> </ul>
<b>Non-Final Demand Site</b>	as defined in Schedule 32
<b>Normal Running Arrangements</b>	The DNO Party's EHV network with no system outages i.e. with no planned outages (e.g. for maintenance) and no unplanned outages (e.g. subsequent to a fault).
<b>Point of Common Coupling</b>	The point on the network where the power flow associated with the single Connectee under consideration, may under some (or all) possible arrangements interact with the power flows associated with other Connectees, taking into account all possible credible running arrangements

<b>Power factor</b>	The ratio of energy transported (kW) to network capacity used (kVA).
<b>Portfolio tariff</b>	A tariff for use of the network by another DNO/IDNO Party where charges are linked to flows out of/into the other DNO/IDNO Party's network from its Connectees or further nested networks.
<b>Primary Substation</b>	A substation on the DNO Party's Distribution System transforming the voltage from EHV to HV, e.g. 33/11kV
<b>Reactive Power</b>	The product of the voltage and current and the sine of the phase angle between them, measured in units of voltamperes reactive.
<b>Regulatory Year</b>	has the meaning given to that expression in the DNO Party's Distribution Licence.
<b>RRP</b>	Regulatory reporting pack, a dataset produced each year by each DNO Party for the Authority.
<b>Sole Use Assets</b>	Assets in which only the consumption or output associated with a single Connectee can directly alter the power flow in the asset, taking into consideration all possible credible running arrangements, i.e. all assets between the Connectee's Entry/Exit Point(s) and the Point(s) of Common Coupling with the general network.
<b>Source Substation</b>	Any substation which connects, via transformers and under Normal Running Arrangements, a particular Network Group to its "upstream" source. For example, for a 33kV group, the Source Substation is taken as the interconnecting 132/33kV grid transformers. A single Network Group may have more than one Source Substation.
<b>Supplier of Last Resort</b>	a supply licensee to which a Last Resort Supply Direction applies, where Last Resort Supply Direction has the meaning given to that expression in the Supply Licence.

<b>System simultaneous maximum load</b>	The maximum load for the GSP Group as a whole.
<b>Transformer Branch</b>	A categorisation used in the derivation of Branch reinforcement costs, for Branches that represent transformation between different voltage levels.
<b>unit</b>	Where the context permits, the word unit refers to kWh.
<b>unit rate</b>	A charging or payment rate based on units distributed or units generated. Unit rates are expressed in p/kWh. Tariffs applied to multi-rate meters and/or using several time bands for charging have several unit rates.

## 4. NETWORK MODELLING

4.1 This section describes the input data required to model the Distribution System for pricing purposes. The FCP methodology requires the Authorised Network Model to be populated with different load and generation levels, corresponding to the Demand (load) and Demand (generation) scenarios being analysed.

### **Authorised Network Model**

4.2 This is the network model that represents the entire EHV network, from the GSP level down to and including the HV busbar at the EHV/HV transformation level and includes all authorised (i.e. sanctioned by the DNO Party) schemes (reinforcement, diversion and new connection works) that are anticipated to be constructed and operational at the time of Maximum Demand in the Regulatory Year for which the Use of System Charges are being calculated. Where a part of a single authorised network project is expected to be commissioned and operational in the Regulatory Year for which Use of System Charges are to be calculated then the DNO Party may, if appropriate, model the fully completed network project. The model should also include a representation of the National Electricity Transmission System.

4.3 The Authorised Network Model may be constructed so that power flow analysis may be conducted separately upon individual Grid Supply Points (or groups of normally interconnected Grid Supply Points) provided that there is no interconnection with adjacent Grid Supply Points considered in the analysis of the respective contingency conditions and any interaction arising from the transfer of demand and generation is correctly accounted for.

4.4 Due to the timings difference between the publication of the LTDS and the creation and publication of use of system tariffs, the Authorised Network Model may contain revised assumptions to the LTDS information.

4.5 A representation of the National Electricity Transmission System shall be included in the model. The complexity of the representation shall be dependent on the level of interconnection of Grid Supply Points via the DNO Party's EHV network. The representation may be:

- (a) a simple generator in-feed at the Grid Supply Point; or

- (b) the use of equivalent circuits to model the interconnections of the Grid Supply Points via the National Electricity Transmission System; or
  - (c) a full replication of the National Electricity Transmission System electrically local to the DNO Party's Distribution System; or
  - (d) a full replication of the whole of the National Electricity Transmission System.
- 4.6 The method of representation should be carefully selected in order to produce a suitable representation of the flows into the DNO Party's EHV network from the National Electricity Transmission System during both Normal Running Arrangements and N-1 Contingency scenarios.
- 4.7 The Authorised Network Model can be modelled so that it takes into account every different section of a circuit, including individual underground cables and overhead line sections, with each different type forming a separate Branch in the model connected between two Nodes. However, this approach can lead to known issues associated with the non-convergence for a power flow solution of models with large numbers of Nodes and large numbers of Branches with very small impedances.
- 4.8 It is acceptable to model a single Branch to represent a composite of multiple subcomponents of underground cable and overhead line. The impedance of a composite Branch can be calculated from the types of subcomponent that make up the overall Circuit length. The rating of a composite Branch can be obtained by examining the rating of all the Branch subcomponents and the lowest rating used as the limiting section that overloads first. For underground cables the impedance and rating is dependent upon the construction type of the cable, cross sectional area of the conductor, conductor material, whether the cable is laid directly in the ground or in ducts. Similarly, for overhead lines the impedance and rating is dependent upon the construction type of the overhead line structures (to take account of the relative positions of the conductors), the conductor material and type and cross sectional area. This information can then be used to determine the Branch impedance and minimum component rating applied in the Authorised Network Model.
- 4.9 As an example, if Figure 2 represents the actual network, the approach described above to produce the EHV network model would reduce it to a nodal model representation as

shown in Figure 2. Table 4.9 shows an example of the data held relating to Figure 2 with the individual subsections being cross referenced to each Branch; Table 4.9A lists the parameters used for the nodal model shown in Figure 3.

**Figure 2 - An example of a section of network to be converted into a nodal model.**

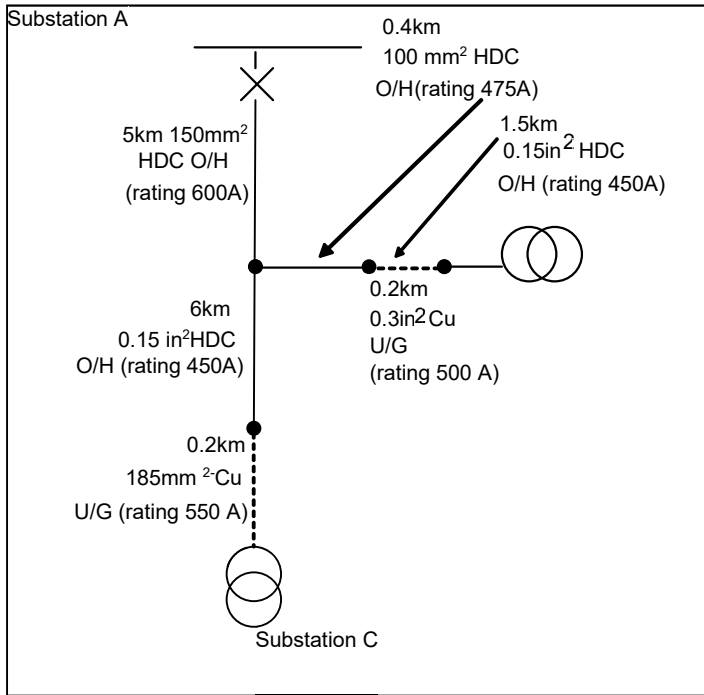

**Figure 3 - The resultant nodal model representative of the example network in Figure 2.**

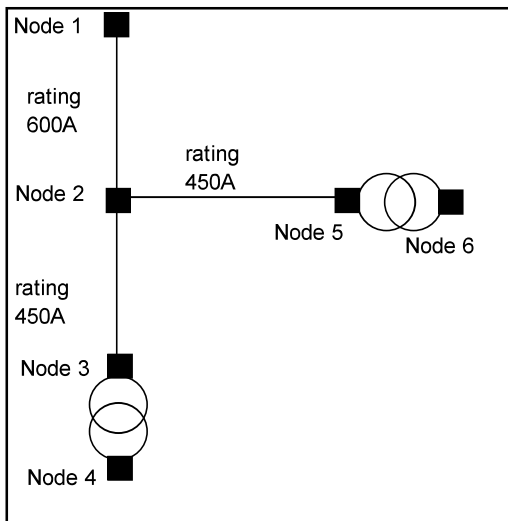

**Table 4.9 – An example of the information held separately relating to Figure 2 which is used to provide the composite Branch parameters.**

Branch	Line Section	Type	Length	Rating	R(p.u.) <sup>2</sup>	X(p.u.)
Node 1 to	1	150mm <sup>2</sup> HDC O/H	5km	600A	0.001	0.01
Node 2 to	1	0.15in <sup>2</sup> HDC O/H	6km	450A	0.0018	0.0054
Node 2 to	2	185mm <sup>2</sup> Cu U/G	0.2km	550A	0.00003	0.0003
Node 2 to	1	100mm <sup>2</sup> HDC O/H	0.4km	475A	0.00004	0.0004
Node 2 to	2	0.3in <sup>2</sup> Cu U/G	0.2km	500A	0.00003	0.0001
Node 2 to	3	0.15in <sup>2</sup> HDC O/H	1.5km	450A	0.00045	0.0013

**Table 4.9A - Composite Branch parameters used for the nodal model shown in Figure 3 above.**

Branch	Branch Rating	R(p.u.)	X(p.u.)
Node 1 to Node 2	600A	0.001	0.01
Node 2 to Node 3	450A	0.00183	0.0057
Node 2 to Node 5	450A	0.00052	0.00185

### **Inclusion of Distribution Systems of LDNOs in the Authorised Network Model**

4.10 Where there is a connection between the DNO Party's Distribution System and an EDCM LDNO Distribution System, the LDNO's network can be represented either by an Exit Point or Entry Point, in a similar manner to that of an ECDM Connectee. In the event that the LDNO's network derives its supply from several different connection points on the DNO Party's Distribution System it may become necessary to model some or the entire LDNO network to ensure that the flows at the boundary between the DNO Party's Distribution System and the Distribution System of the LDNO are representative of those expected under Normal Running Arrangements and Contingency scenarios.

---

<sup>2</sup> For the sake of simplicity ratings, resistance (R) and reactance(X) values given above are assumed and should be used only for illustrative purposes such as the given example to calculate equivalent Branch ratings and parameters for a composite Branch.

## 5. NETWORK DEMAND DATA

5.1 This section 5 describes the input data required to model the Distribution System for FCP purposes.

### **Network Demand Data (Load)**

5.2 The demands (load) in the Authorised Network Model will be based on LTDS network data as produced by the DNO Party. It is necessary to create a 10-year demand (load) set to assess the network for the 10-year study period. The following Network Demand Data is required as the basis for populating the Authorised Network Model:

- (a) Maximum Demands at each Connection Node;
- (b) Maximum Demands at Grid Supply Points; and
- (c) Maximum Demands at Bulk Supply Points or other intermediate substations.

5.3 The load estimates in the LTDS are normally cleansed and validated ensuring:

- (a) maximum loads that are recorded reflect Normal Running Arrangements;
- (b) application of suitable weather correction is considered, if appropriate; and
- (c) latent demand is accounted for in accordance with the guidance contained in ETR 130.

5.4 The LTDS forecasts the demand (loads) for 5 years. The remaining years (years 6 to 10) are to be assessed by the DNO Party using the appropriate engineering forecasts and local knowledge and information.

5.5 Where new EDCM Customers are included in the Authorised Network Model, their demands will be individually assessed and estimated by the DNO Party.

### **Network Demand Data (Generation)**

5.6 Existing EDCM Generation in the model will be based on the Maximum Export Capacity for the EDCM Generation. Depending on the power flow studies being undertaken these may be scaled by an F factor as described in ER P2/6. Where

sufficient actual recorded network data exists, a generator's site-specific F factor may be calculated, as described in ETR 130.

### Modelling of Customers with both Load and Generation

- 5.7 'Import/Export' Connectees (Connectees that have the ability to import electricity from and export electricity to the Distribution System) require special consideration.
- 5.8 The flows associated with these Connectees should contribute solely to the Network Demand Data (Load) element of the Maximum Demand Data and Maintenance Demand Data data sets. These demands should be derived as described in the Maximum Demand Data for Demand (Load) Analysis and Maintenance Demand Data for Demand (Load) Analysis.

### Diversity Factors

- 5.9 The demands that are required to be populated in the Authorised Network Model need to be set so the modelled demand supplied through a GSP is equal to the Maximum Demand at the GSP as described in the Network Demand Data (Load) section. This may be achieved by using Diversity Factors to modify the Connection Node maximum demands or by the use of Negative Load Injections. The following describes acceptable methods to achieve this requirement.
- 5.10 To aid the description a simple network is shown in Figure 4 below which will provide a basis for the examples.

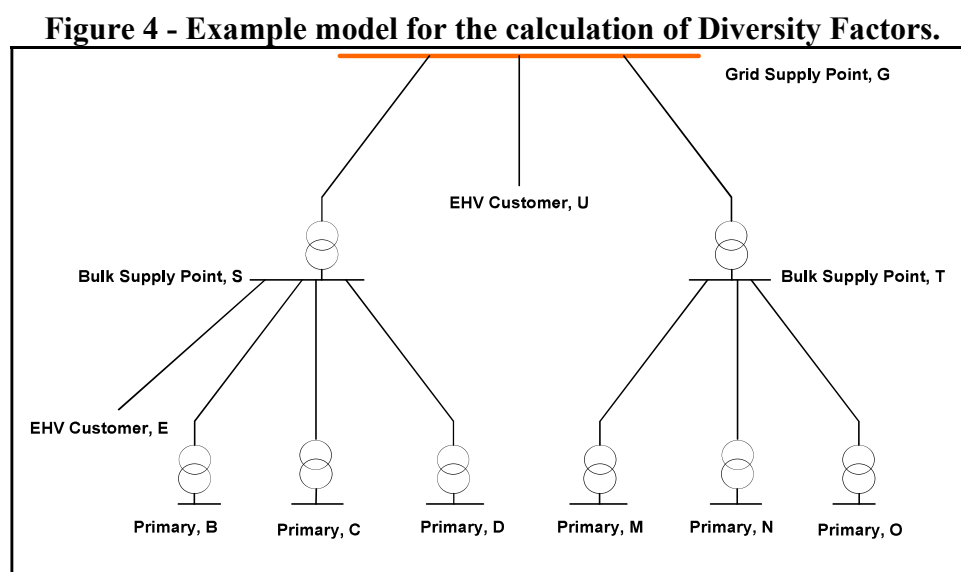

### Method 1 - Hierarchical Diversity Factors

5.11 Networks are typically built as a hierarchy. The typical hierarchy levels are Primary Substation, Bulk Supply Points and Grid Supply Points. There may also occasionally be other intermediate levels such as 132kV switching substations. A Diversity Factor can then be calculated for each required substation. The Diversity Factor is calculated as the maximum demand at that substation divided by the sum of the maximum demands of all points of the network at the next lower hierarchy served by that substation plus an allowance for losses in that part of the network.

5.12 In our example, for Bulk Supply Point, S (see Figure 4), supplying three Primary Substations, B, C and D, and an EDCM Customer E, the Diversity Factor is derived as:

$$DF_S = \frac{MD_S}{MD_B + MD_C + MD_D + MD_E + losses_{S \rightarrow}}$$

**Where:**

$DF_S$	=	diversity factor
$MD_S$	=	maximum demand at substation S
$MD_B$	=	maximum demand at substation B
$MD_C$	=	maximum demand at substation C
$MD_D$	=	maximum demand at substation D
$MD_E$	=	maximum demand at substation E
$losses_{S \rightarrow}$	=	line losses in the downstream network supplied from Bulk Supply Point S

5.13 Similarly for Grid Supply Point, G, supplying two Bulk Supply Points, S and T, and an EDCM Customer U, the Diversity Factor is derived as:

$$DF_G = \frac{MD_G}{MD_S + MD_T + MD_U + losses_{G \rightarrow}}$$

**Where:**

$DF_G$	=	diversity factor
$MD_G$	=	maximum demand at substation G
$MD_S$	=	maximum demand at substation S
$MD_T$	=	maximum demand at substation T
$MD_U$	=	maximum demand at substation U
$losses_{G \rightarrow}$	=	line losses in the downstream network supplied from Grid Supply Point G

5.14 Diversity Factors are calculated separately for each substation at each level. In our example, Diversity Factors would be calculated for substations S, T, and G. A Net Diversity Factor is then applied to each Connection Node based on the product of Diversity Factors of all the Substations that supply that Connection Node. In the example, the following Net Diversity Factors would be applied to each of the Connection Nodes.

**Table 5.14 - Calculation of Net Diversity Factors - Hierarchical Diversity Factors.**

Connection Node	Maximum Demand	Net Diversity Factor	Demand to be applied to the Network Model
Primary, B	$MD_B$	$DF_G * DF_S$	$DF_G * DF_S * MD_B$
Primary, C	$MD_C$	$DF_G * DF_S$	$DF_G * DF_S * MD_C$
Primary, D	$MD_D$	$DF_G * DF_S$	$DF_G * DF_S * MD_D$
EHV Customer, E	$MD_E$	$DF_G * DF_S$	$DF_G * DF_S * MD_E$
Primary, M	$MD_M$	$DF_G * DF_T$	$DF_G * DF_T * MD_M$
Primary, N	$MD_N$	$DF_G * DF_T$	$DF_G * DF_T * MD_N$
Primary, O	$MD_O$	$DF_G * DF_T$	$DF_G * DF_T * MD_O$
EHV Customer, U	$MD_U$	$DF_G$	$DF_G * MD_U$

5.15 Diversity Factors are applied to both the Active Power and Reactive Power demands at each Connection Point thus ensuring the power factor of the demand remains unchanged.

### **Method 2 - Single Diversity Factors**

5.16 Where a network has significant interconnection or subject to regular rearrangement (e.g. Primary Substations being transferred between Bulk Supply Points) the use of a single Diversity Factor for all the demand supplied by a Grid Supply Point (or a set of interconnected Grid Supply Points) may be appropriate. The Diversity Factor for the GSP is calculated as the Maximum Demand at the GSP divided by the sum of all the Maximum Demands of each Connection Node supplied from that GSP plus an allowance for losses.

- 5.17 Using the example shown in Figure 4 a single Diversity Factor for Grid Supply Point, G can be calculated as:

$$DF_{G1} = \frac{MD_G}{MD_B + MD_C + MD_D + MD_E + MD_M + MD_N + MD_O + MD_U + losses}$$

Where:

$DF_{G1}$	=	diversity factor
$MD_G$	=	maximum demand at substation G
$MD_B$	=	maximum demand at substation B
$MD_C$	=	maximum demand at substation C
$MD_D$	=	maximum demand at substation D
$MD_E$	=	maximum demand at substation E
$MD_M$	=	maximum demand at substation M
$MD_N$	=	maximum demand at substation N
$MD_O$	=	maximum demand at substation O
$MD_U$	=	maximum demand at substation U
losses	→	network losses in the system shown in Figure 4

- 5.18 The Net Diversity Factor in this method is equal to the calculated single Diversity Factor. In the example the following Net Diversity Factors would be applied to each of the Connection Nodes.

**Table 5.18 - Calculation of Net Diversity Factors - Single Diversity Factors**

Connection Node	Maximum Demand	Net Diversity Factor	Demand to be applied to the Network Model
Primary, B	$MD_B$	$DF_{G1}$	$DF_{G1} * MD_B$
Primary, C	$MD_C$	$DF_{G1}$	$DF_{G1} * MD_C$
Primary, D	$MD_D$	$DF_{G1}$	$DF_{G1} * MD_D$
EHV Customer, E	$MD_E$	$DF_{G1}$	$DF_{G1} * MD_E$
Primary, M	$MD_M$	$DF_{G1}$	$DF_{G1} * MD_M$
Primary, N	$MD_N$	$DF_{G1}$	$DF_{G1} * MD_N$
Primary, O	$MD_O$	$DF_{G1}$	$DF_{G1} * MD_O$
EHV Customer, U	$MD_U$	$DF_{G1}$	$DF_{G1} * MD_U$

- 5.19 Diversity Factors are applied to both the Active Power and Reactive Power demands at each Connection Point thus ensuring the power factor of the demand remains unchanged.

### **Method 3 - Negative Load Injections**

- 5.20 A Negative Load Injection is a negative value of load calculated and applied to a source substation within the network model to represent the effects of diversity between associated downstream demands upon the actual demand observed at the source substation.
- 5.21 Negative Load Injections are applied at a substation to ensure that the demand at the substation equals the required Maximum Demand for that substation. Negative load injections are normally placed at Bulk Supply Points, other intermediate substations (such as 132kV switching substations) and Grid Supply Points.
- 5.22 The amount of negative load injection required to be applied at a substation is calculated as the maximum demand at that substation minus the sum of the maximum demands of all points of the network at the next lower hierarchy served by that substation plus an allowance for losses in that part of the network.
- 5.23 In our example, for Bulk Supply Point, S, supplying three Primary Substations, B, C and D, and an EDCM Customer E, Negative Load Injection is derived as:

$$NLI_S = MD_S - (MD_B + MD_C + MD_D + MD_E + losses_{S \rightarrow})$$

#### **Where:**

$NLI_{G1}$	=	negative load injection
$MD_S$	=	maximum demand at substation S
$MD_B$	=	maximum demand at substation B
$MD_C$	=	maximum demand at substation C
$MD_D$	=	maximum demand at substation D
$MD_E$	=	maximum demand at substation E
$losses_{S \rightarrow}$	=	line losses in the downstream network supplied from Grid Supply Point G

- 5.24 Similarly for Grid Supply Point, G, supplying two Bulk Supply Point, S and T, and an EDCM Customer U, Negative Load Injection is derived as:

$$NLI_G = MD_G - (MD_S + MD_T + MD_U + losses_{S \rightarrow})$$

**Where:**

$NLI_G$	=	negative load injection
$MD_G$	=	maximum demand at substation G
$MD_S$	=	maximum demand at substation S
$MD_T$	=	maximum demand at substation T
$MD_U$	=	maximum demand at substation U
$losses_{S \rightarrow}$	=	line losses in the downstream network supplied from Grid Supply Point G

- 5.25 The value of Negative Load Injection calculated is a negative number. This is modelled as a negative load (or in fact generation) at the substation busbar so that the incoming flow matches the required maximum demand for that substation. Negative Load Injections are applied as an Active Power injection only. No Reactive Power injection is applied.

**An Implementation of Diversity Factors Using Multiple Load Sets**

- 5.26 The use of Network Groups for analysis in the FCP methodology allows for different levels of the network to be loaded independently with different Network Demand Data (Load). By loading all Primary Substations and EDCM Customers with their maximum demands as recorded in the LTDS, the total system demand at each GSP will be significantly higher than the demand reported to the Independent System Operator and Planner for the Week 24 submission. This excessive loading of the higher voltage network levels would give rise to premature reinforcement at this level as diversity has not been considered. However, when considering this Primary Substation load set only reinforcements between the lower voltage busbars of the Primary Substations and the lower voltage busbars of the supplying higher voltage substations are considered. The assets observed for overloads and hence need reinforcing are therefore the Primary Substation transformers and their supplying EHV Circuits, if applicable.

**Example on a radial network**

- 5.27 An example showing a radial network loaded with a Primary Substation load set is shown in Figure 5 and the shaded box shows the assets considered when looking for overloads. All upstream Branches should be ignored if they overload as these will be tested by a separate load set.
- 5.28 With the Primary Substation level tested, the loads connected to Primary Substations and EDCM Customers may be removed and the BSP substations maximum demands loaded as per the LTDS. An alternative approach to removing these loads would be to retain them in the network model but to scale them using appropriate diversity factors to match Maximum Demands at the BSP substations (as set out in Method 1).
- 5.29 The BSP load set can then be used to test the network assets between the BSP lower voltage busbar and the supplying GSP. Figure 6 shows the same network but with the BSP loads applied, the assets in the shaded box are the ones observed for overloads. It is accepted that using all BSP maximum demands (load) the resultant loads at the GSPs will not equal the maximum demands reported to Independent System Operator and Planner for the Week 24 submission. The extra demand (load) may overload the GSP transformers, however, these are zero-cost Branches as they are transmission assets; the Reinforcement Cost Calculation Principles section describes zero-cost Branches further.

**Figure 5 - Network schematic showing Primary Substations loads removed and BSP loads added, also showing the network assets monitored for overloads.**

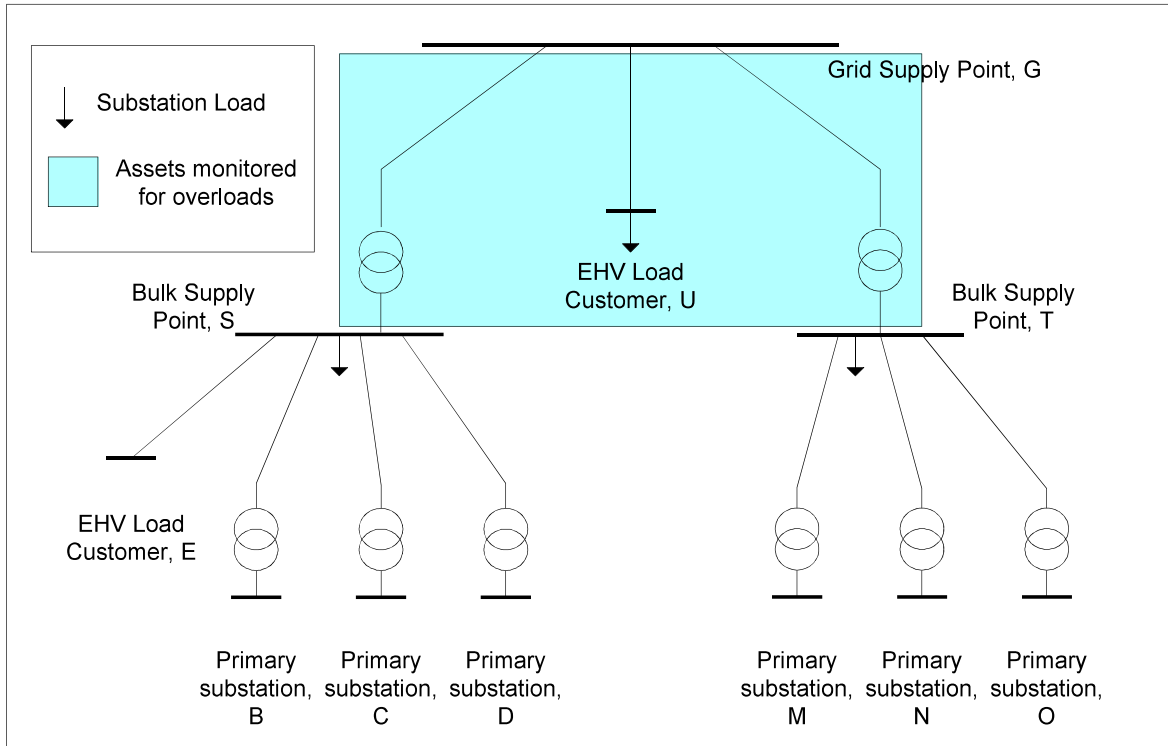

**Figure 6 - Network schematic showing Primary Substations loaded with maximum demands and the network assets monitored for overloads.**

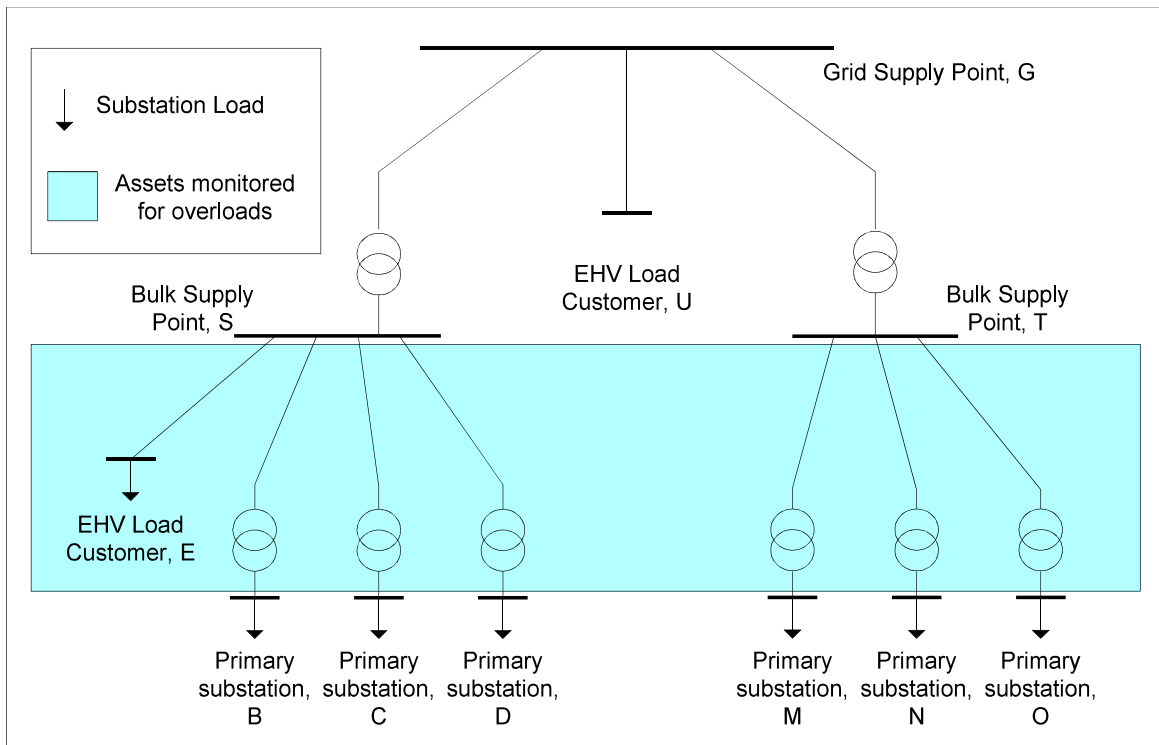

**An implementation of diversity factors using multiple load sets (meshed and radial mix)**

5.30 Where networks are comprised of a mix of radial and meshed sections (such as shown in Figure 6), it may not be appropriate to consider all substations as being loaded to their maximum demands. This implementation involves the application of hierarchical Diversity Factors to loads on meshed sections while the loads on the radial sections remain unchanged. The procedure is described below.

**Calculation of hierarchical diversity factors:**

5.31 Hierarchical diversity factors for each network group are calculated as described in Method 1.

**Application of the hierarchical diversity factors:**

5.32 The hierarchical diversity factors are applied only to the loads on meshed sections (see table 5.34 below).

**Multiple network analyses:**

5.33 The Primary Substation level is loaded and used to test for overloaded Branches between the Primary Substations and the BSPs (excluding any BSP transformers). To test for overloaded Branches between a BSP and a GSP, all downstream demand (load) supplied from the BSPs are removed - for example, demand (load) connected to Primary Substations B, C, D and EDCM Customer E would be removed when testing for overloaded Branches between BSP S and GSP G. BSP loads are then applied to the network model.

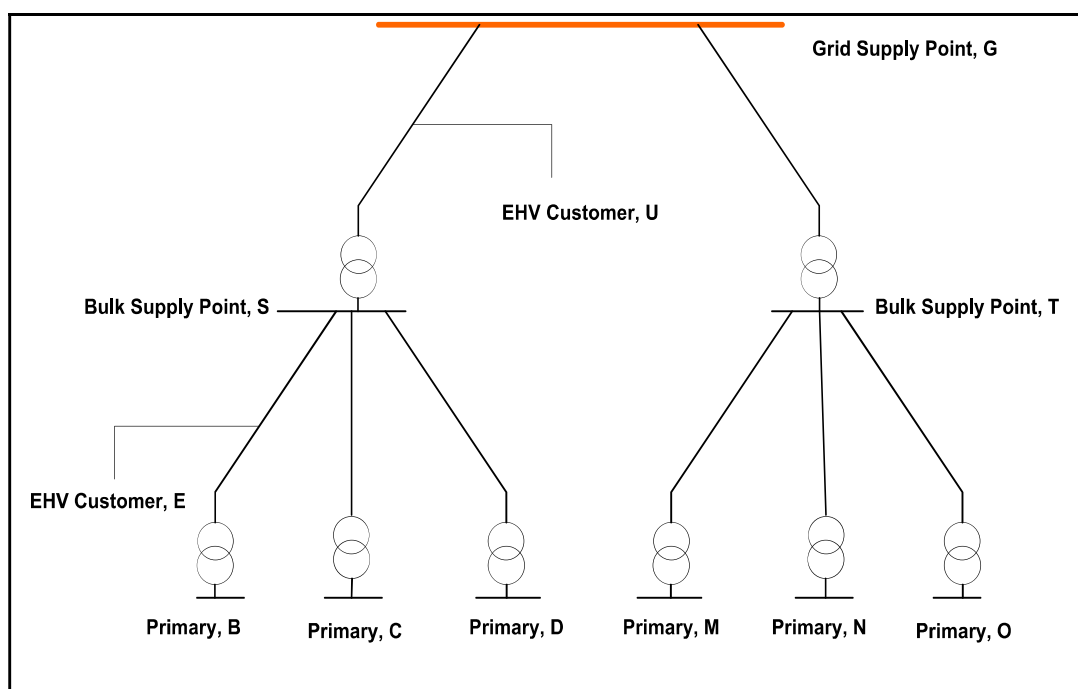
**Figure 7 - Implementation of Diversity Factors using multiple load sets**

5.34 The final load which applied at each substation is shown in table 5.34 below:

**Table 5.34 - Calculation of Diversity Factors - Multiple load sets (meshed and radial mix).**

Connection Node	Maximum Demand	Diversity Factor	Demand to be applied to the Network Model
Primary, B	$MD_B$	$DF_S$	$MD_B * DF_S$
Primary, C	$MD_C$	1.00	$MD_C$
Primary, D	$MD_D$	1.00	$MD_D$
EHV Customer, E	$MD_E$	$DF_S$	$MD_E * DF_S$
Primary, M	$MD_M$	1.00	$MD_M$
Primary, N	$MD_N$	1.00	$MD_N$
Primary, O	$MD_O$	1.00	$MD_O$
EHV Customer, U	$MD_U$	$DF_G$	$MD_U * DF_G$
Bulk Supply Point, S	$MD_S$	$DF_G$	$MD_S * DF_G$
Bulk Supply Point, T	$MD_T$	1.00	$MD_T$

## **Maximum Demand Data for Demand (Load) Analysis**

### **Network Demand Data (Generation)**

- 5.35 The Network Demand Data (Generation) element of the Maximum Demand Data shall be constructed with generation output set at zero unless the generation can be considered to have a contribution to security of supply under ER P2/6, in which case the ER P2/6 level of export shall be modelled.
- 5.36 The contribution of distributed generation to security of supply is dealt with in ER P2/6 through the application of F factors. Each distributed generator is assigned an F factor and this represents the percentage of the generator's declared net capacity that can be considered when assessing network security. ER P2/6 also uses the term 'Persistence' to reduce the F factor for intermittent generation, as the time period (in hours) for which its contribution to security is being assessed increases. Table 2-4 of ER P2/6 recommends values of 'Persistence'; these values are dependent on the demand class being assessed. The value of 'Persistence' to be used for intermittent generation will be as stated in Table 2-4 of ER P2/6 for 'Other outage', using the maximum GSP (or GSP groups') demand instead of the demand class of the demand group.

### **Network Demand Data (Load)**

- 5.37 The Network Demand Data (Load) element of the Maximum Demand Data shall be constructed based on the Maximum Demands for each load point and either amended (Diversity Factors) or enhanced (Negative Load Injections) by the chosen diversity method (see the Diversity Factors section).
- 5.38 For the diversity methods 1 and 2 the maximum demand load estimates for each load point is scaled so that the modelled load in the Maximum Demand Data reflects the Grid Supply Point maximum load estimates under Normal Running Arrangement.
- 5.39 The application of diversity in the derivation of this data needs to be carefully considered and aim to produce, where possible, within the constraints of a single set of demand data, power flows that reflect typical flows under the Maximum Demand conditions; but also enable calculations to be undertaken upon an Authorised Network Model.

- 5.40 In considering the derivation of the Maximum Demand Data, it must be recognised that power flow analysis based on this Network Demand Data may not replicate the maximum power flow through individual assets that could be seen under all N-1 Contingency conditions, due to the limitations of analysis based upon a limited number of sets of Network Demand Data.

### **Maintenance Demand Data for Demand (Load) Analysis**

#### **Network Demand Data (Generation)**

- 5.41 The Network Demand Data (Generation) element of the Maintenance Demand Data shall be the same as that modelled for the Maximum Demand Data.

#### **Network Demand Data (Load)**

- 5.42 The Network Demand Data (Load) element of the Maintenance Demand Data shall be constructed using the Maximum Demand Data load values scaled down to a minimum of 67% to represent the peak load demands observed during the maintenance period. Where actual loads are higher than 67% of Maximum Demand Data they can be used instead.
- 5.43 For the diversity methods 1 and 2 the maintenance demand load estimates for each load point are scaled so that the modelled load in the Maintenance Demand Data reflects the Grid Supply Point maintenance peak load estimates under Normal Running Arrangement.
- 5.44 The application of diversity in the derivation of this data needs to be carefully considered and aim to produce, where possible, within the constraints of a single set of demand data, power flows that reflect typical flows under the peak maintenance demand conditions; but also enable calculations to be undertaken upon an Authorised Network Model.
- 5.45 In considering the derivation of the Maintenance Demand Data, it must be recognised that power flow analysis based on this Network Demand Data may not replicate the maximum power flow through individual assets that could be seen under all N-2 Contingency conditions, due to the limitations of analysis based upon a limited number of sets of Network Demand Data.

## 6. NETWORK GROUPS

6.1 For the purpose of forecasting future reinforcement the network is broken down into a number of Network Groups. The use of Network Groups for analysis is an important stage in assessing security of supply requirements given in ER P2/6. Network Groups are defined at hierarchical levels, each level being defined by the operating voltage of the source substations, such that separate Network Groups are defined for Primary Substation, BSP and GSP levels.

6.2 Each Network Group is a part of the Distribution System that consists of:

- (a) the transformation assets at a source substation; and
- (b) the network that:
  - (i) operates at the same voltage as the lower voltage of these transformation assets; and
  - (ii) is electrically connected to these transformation assets, under Normal Running Arrangements, excluding electrical connection through assets operating at voltages other than the lower voltage of the transformation assets.

6.3 The following exceptions apply:

- (a) where a source substation operates, under Normal Running Arrangements, with open point(s) on the lower voltage busbar such that there are separate sections of the busbar that are not electrically connected at the same voltage as the busbar, then these separate sections of busbar, and their associated network, shall be considered as separate Network Groups; and
- (b) where multiple source substations, with the same lower voltage of transformation assets, operate in parallel, under Normal Running Arrangements, through network operating at the same voltage as the lower voltage of the transformation assets, then these substations and their associated network shall be considered as a single Network Group.

6.4 Where a Network Group has, under Normal Running Arrangements:

- (a) no demand(load) or demand (generation) connected either within the Network Group, or any lower voltage Network Group associated with it; and
- (b) the Network Group exists solely for the purposes of providing security of supply support to an adjacent Network Group, through closure of open point(s) between such Network Groups,

then such Network Groups shall be considered as part of the adjacent Network Group to which they provide security of supply support (an example of such instances would be Network Groups that would otherwise be associated with transformers that operate on 'hot standby' under Normal Running Arrangements).

- 6.5 The demand (load or generation) that is considered to be associated with each Network Group is the demand that is connected within the Network Group and also within any lower voltage Network Group that is connected the source Network Group under Normal Running Arrangements.
- 6.6 Figure 8 shows an example network broken down into a number of Network Groups. This example shows how individual Network Groups may include multiple source substations. This is illustrated by the Level 2 group shown as BSP Group 1. In this example both BSP1 and BSP2 are Source Substations which are encompassed within a single Network Group, due to operation of an interconnected 33kV network between these substations under Normal Running Arrangements.
- 6.7 Separate Network Groups may be physically connected by circuits but under Normal Running Arrangements there are no flows between the Network Groups either by means of a normally open switch or normally open circuit breaker. Figure 9 shows the same example network as seen in Figure 8 except now the 33kV circuit interconnection between BSP 1 and BSP 2 is run open, creating two level 2 BSP Network Groups, where previously there was only one, with their own separate Source Substations.

6.8 Not all network levels discussed above are applicable across Great Britain with respect to the FCP methodology. In Scotland for example only Level 2 and Level 3 Network Groups are considered as voltages above 33kV are considered transmission and so are not included in the distribution pricing models. In England and Wales all three levels (Level 1, Level 2 and Level 3) as shown in (Figure 9) are considered, although depending on the network voltage transformations the Level 2 Network Group may not be present in some cases, as shown at Primary 5. In this case Primary 5's voltage transformation converts 132kV straight to 11kV and hence there is no intermediate distribution through a BSP, Level 2.

**Figure 8 - Example network showing three levels of Network Groups.**

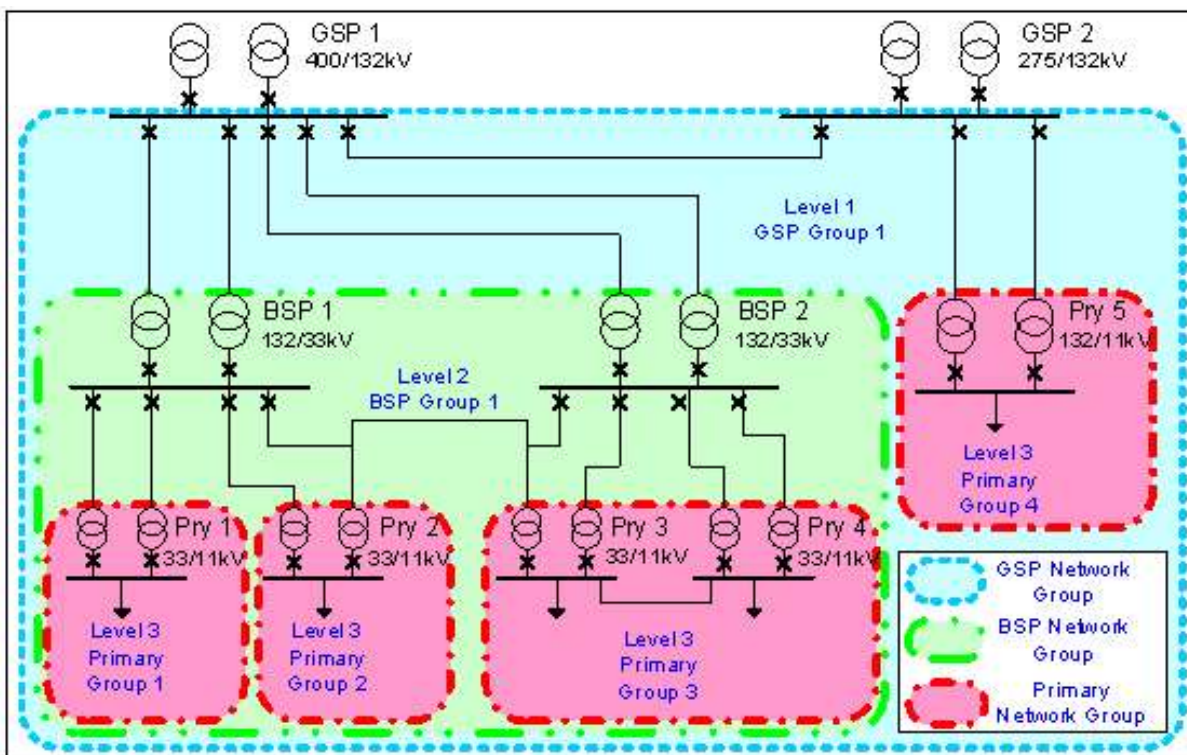

**Figure 9 - Example network similar to Figure 8 showing that the addition of the Normally Open Point (NOP) has created two level 2 BSP Network Groups.**

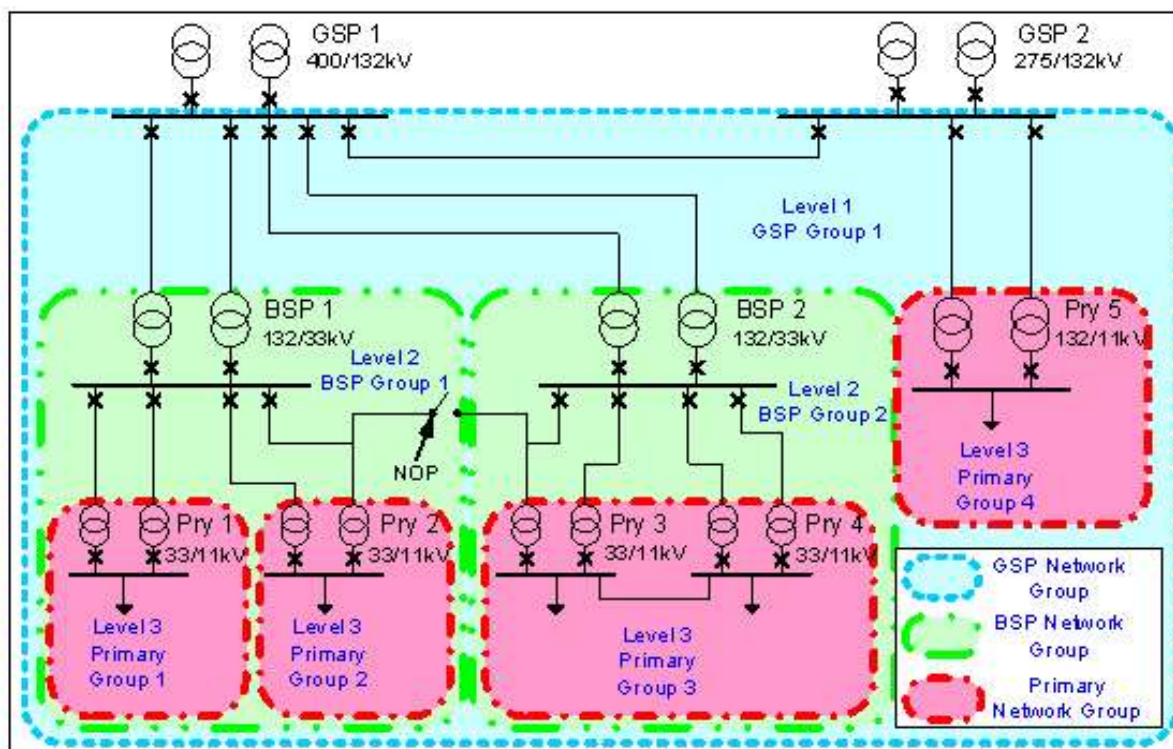

## 7. POWER FLOW ANALYSIS PROCESS

- 7.1 This section 7 describes the power flow analysis undertaken for pricing purposes. The purpose of power flow analysis is to determine when overloads occur on the Authorised Network Model caused by forecast changes in demand (load) in each Network Group using Contingency Analysis. Each overloaded chargeable Branch will then in turn be given a reinforcement cost which will be used in the calculation of Network Group incremental charges using the FCPLoad formula as shown in section 9 below (Calculation of Network Group Incremental Charges). The power flow is also known as Demand (Load) Analysis.:
- 7.2 Figure 10 shows a flow chart for the FCP methodology showing the overall processes and stages.

Figure 10 - Flowchart of the FCP pricing model.

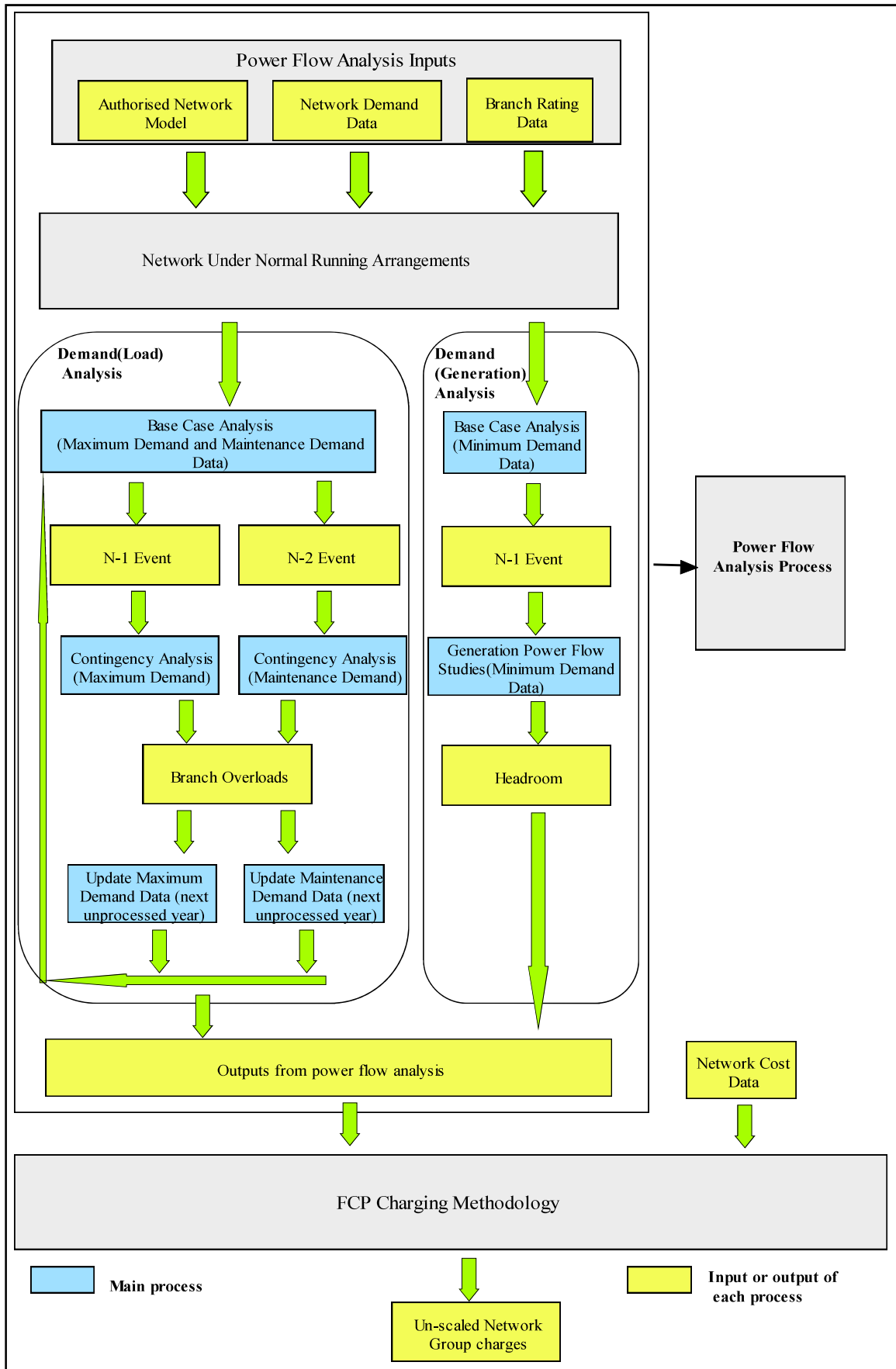

## **Demand (Load) Analysis**

7.3 This section examines the processes for identifying overloads and their respective timings by analysing the Authorised Network Model in succession over a 10-year period starting from the Regulatory Year for which the Use of System Charges are being calculated. During this analysis only changes in demand (load) are modelled over the 10-year period.

## **Contingency Analysis**

7.4 In line with planning standards for network security<sup>3</sup> Contingency Analysis is undertaken to identify the assets in each Network Group that will require reinforcement; this is achieved using AC load flow studies. The objective of the Contingency Analysis is to identify the Branches that require reinforcement and to determine the time (years) to reinforcement.

7.5 The Contingency Analysis is based on all credible outages that could affect the DNO Party's Distribution System. Both N-1 Events and where necessary, N-2 Events are modelled and the consequential network actions required to meet the security of supply requirements of ER P2/6 and the agreed level of security of supply to individual Connectees. For example, where appropriate, it may include constraints in distributed generation output, customer demand reductions, automatic switching schemes and manual switching. Such switching operations may include the transfer of demand or generation, as appropriate. For the N-1 Contingencies the model is set up using the Maximum Demand Data and appropriate Branch Ratings. For the N-2 Contingencies the N-2 Event is assumed to take place at the same time as a planned outage and therefore the Maintenance Demand Data and appropriate Branch Ratings are used. Only N-2 Events applicable to ER P2/6 demand class E<sup>4</sup> shall be considered within the Contingency Analysis, where the assessment of demand class is performed based upon the in the Regulatory Year for which the Use of System Charges are being calculated.

---

<sup>3</sup> Network security is a licence condition embodied in ER P 2/6

<sup>4</sup> ER P2/6 specifies the normal level of system security for distribution networks, classified in ranges of group demand. ER P2/6 Class E specifies the security of supply requirements where the group demand is classified as over 300MW and up to 1500MW

- 7.6 The N-1 and N-2 Contingency Analyses are repeated for each year of the specified 10 year planning period as shown in Figure 10. The timing for each overloaded Branch is determined from these analyses as described in Figure 11 (see Demand (Load) Analysis block). The overloaded Branches are identified by running the appropriate N-1 or N-2 Contingency Analyses on the networks populated by Maximum Demand Data or Maintenance Demand Data, respectively. If any of these two analyses cause a Branch overload for the considered year  $u$ , the time to reinforcement of the Branch is set to  $Y=u$ . If a Branch overload is identified in both analyses the time to reinforcement is set to the earliest year the overload is found.
- 7.7 As the load flow analysis progresses through the 10-year planning period the same reinforcements will be identified and to avoid double counting of reinforcements only new Branch reinforcements each year are considered. It should be noted that the network model is static and hence not updated if a reinforcement is required.
- 7.8 The outputs from the Contingency Analysis will include all EHV network Branches which are overloaded, which Network Group they belong to, the time at which they were overloaded and the demand (load) that causes the overload.

**Figure 11 - Reinforcements considered over the 10 year planning period.**

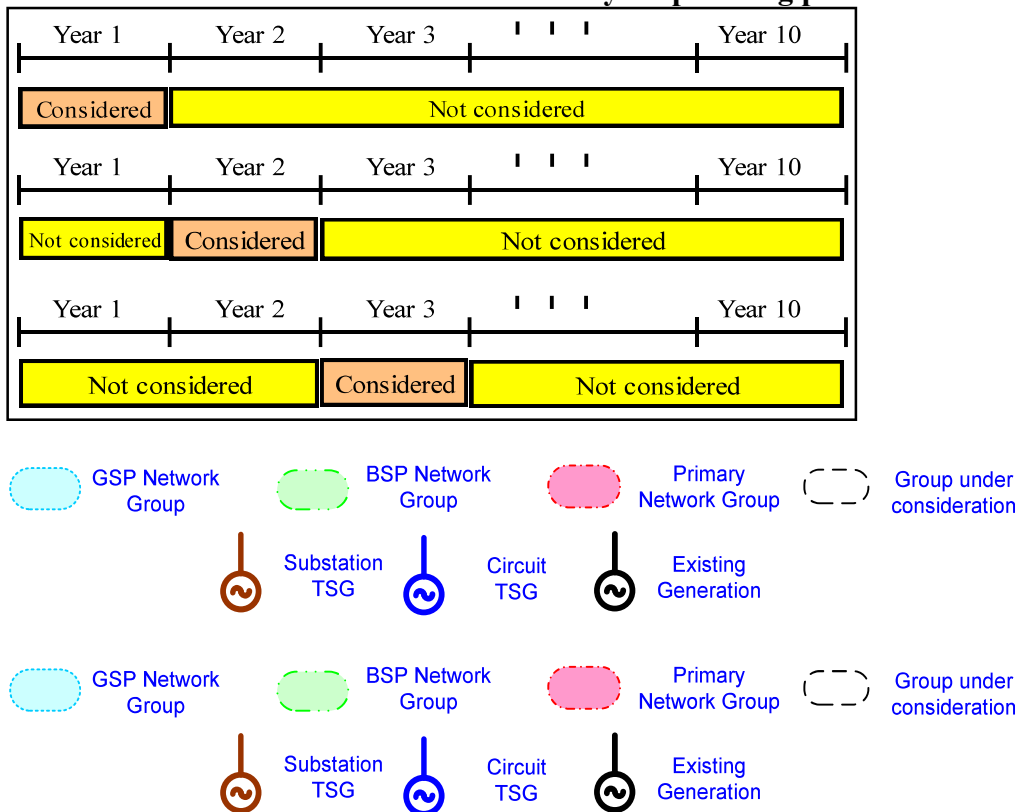

## 8. CALCULATION OF REINFORCEMENT COSTS

- 8.1 The calculation of Network Group incremental charges for demand (load/) is based on the outputs obtained from the power flow analysis process which is discussed in the section 9 (Calculation of Network Group incremental charges) below (see Figure 12).
- 8.2 Using the results of the power flow analysis and reinforcement costs, Network Group incremental charges for demand (load/) can be calculated based on the formulae presented in section 9 (Reinforcement Cost Calculation Principles) below. The main principles for the calculation of reinforcement costs are given in section 8.3 (Reinforcement Cost Calculation Principles) below.

### **Reinforcement Cost Calculation Principles**

- 8.3 These are general principles for the calculation of the reinforcement costs:
- (a) Each Branch within the Authorised Network Model should be considered as being one of three types:-
    - (i) Transformer Branches - which represent Branches at substations that provide transformation between different voltage levels.
    - (ii) Circuit Branches - which represent an interconnection (or part of an interconnection) between substations and which operate at a single voltage level.
    - (iii) Zero-cost Branches - these Branches exist in the network model but have zero reinforcement costs.
  - (b) Zero-cost Branches shall include, but not be limited to:-
    - (i) Branches that represent assets that are not part of the DNO Party's Distribution System for which marginal costs are being calculated e.g. sections of the National Electricity Transmission System, adjacent Distribution Systems etc.
    - (ii) Branches that represent Sole Use Assets.

- (iii) Branches that represent internal connections within substations, other than installed transformation (e.g. bus couplers, bus section circuit breakers etc.)
- (c) The cost of reinforcement for a Branch shall be constructed from typical unit costs appropriate to the categorisation of the Branch and the components represented.
- (d) The typical unit costs used to derive the cost of reinforcement for a Branch shall:
  - (i) reflect the modern equivalent asset value of reinforcing the particular asset;
  - (ii) include overheads directly related to the construction activity;
  - (iii) include building and civil engineering works, in unmade ground.
- (e) A cost of reinforcement shall be allocated to each Transformer Branch and Circuit Branch taking account where possible of:
  - (i) the voltage of operation of the Circuit (or in the case of Transformer Branches, the voltages of transformation);
  - (ii) the existing mix of overhead line and underground cable within Circuit Branches;
  - (iii) the requirements and costs of similar historic reinforcement projects.
- (f) The costs associated with substation plant and equipment (such as circuit breakers, switches, protection equipment, earthing devices etc.) shall be included within the cost of reinforcement and allocated appropriately across the Transformer Branches and Circuit Branches to which they relate.
- (g) The typical unit costs used to derive the cost of reinforcement for a Branch shall:
  - (i) reflect the modern equivalent asset value of reinforcing the particular asset;
  - (ii) include overheads directly related to the construction activity;

- (iii) include building and civil engineering works, in unmade ground.

### **Branch Rating Data**

- 8.4 Each Branch in the Authorised Network Model needs to be assigned a Branch Rating appropriate to each analysis scenario considered. Where a Branch represents a number of components (for instance, a number of sections of overhead line and/or underground cable) then the rating of that Branch is calculated by looking at the ratings of all the subcomponents and determining the lowest value. The rating of a transformer shall be the capability of the transformer to supply load at its secondary terminals.

## **9. CALCULATION OF NETWORK GROUP INCREMENTAL CHARGES**

### **FCP load incremental charge**

- 9.1 In each Network Group reinforcements within a 10-year horizon are identified. Reinforcements that are a part of lower voltage Network Groups are excluded. From Figure 8 it can be seen that:

- (a) In the GSP Network Group (Level 1) the Branches that are considered for reinforcement are only the EHV Branches connecting the GSPs to the BSPs, the transformers connected to the GSPs are transmission Branches and so not included in the EDCM. All of the other network Branches fall into the lower voltage Network Groups (Level 2 and Level 3).
- (b) In the BSP Network Groups (Level 2) incremental charges are derived from the reinforcement costs of the BSP transformers and the outgoing Network Group Branches.
- (c) In the Primary Network Groups (Level 3) incremental charges are derived from the reinforcement costs related only to the Primary transformer as the 11kV circuits are not considered in the EDCM.

- 9.2 The following charging function is used to derive the Network Group incremental charge (£/kVA/annum) for demand (load):

$$FCP_{load} = \sum_j \frac{i \left( \frac{A_j}{C_l} \right) \left( \frac{D}{C_l} \right)^{\frac{2i}{g_l} - 1}}{1 - e^{-iT}}$$

**Where:**

$FCP_{load}$  = FCP load incremental charge (£/kVA/annum)

$j$  = index of Branch whose reinforcement is required in the planning period

$i$  = discount rate, which is set to equal the latest pre-tax real weighted average cost of capital (CC below) for each DNO Party calculated using the following formula:

$$CC = (\text{Gearing Assumption} \times \text{Pre-Tax Cost of Debt}) + (1 - \text{Gearing Assumption}) \times (\text{Post Tax Cost of Equity} / (1 - \text{Corporation Tax Rate}))$$

where:

Gearing Assumption is set to the ‘Notional gearing’ value for the regulatory year for which tariffs are being set in the latest version of the PCFM (InputSummary sheet, Finance inputs, Vanilla allowed return on capital) prepared for the relevant DNO Party for publication with such tariff setting on the DNO Party’s website;

Pre-Tax Cost of Debt is set to the ‘Allowed return on debt’ value for the regulatory year for which tariffs are being set in the latest version of the PCFM (InputSummary sheet, Finance inputs, CAPM calculator tool: allowed return on debt) prepared for the relevant DNO Party for publication with such tariff setting on the DNO Party’s website;

Post Tax Cost of Equity is set to the ‘Allowed return on equity’ value for the regulatory year for which tariffs are being set in the latest version of the PCFM (InputSummary sheet, Finance inputs, CAPM calculator tool: allowed return on equity) prepared for the relevant DNO Party for publication with such tariff setting on the DNO Party’s website; and

Corporation Tax Rate is set to the ‘Corporation tax rate’ value for the regulatory year for which tariffs are being set in the latest version of the PCFM (InputSummary sheet, Tax, Tax policy) prepared for the relevant DNO Party for publication with such tariff setting on the DNO Party’s website.

In the event of any value not being available from the above data sources, the DNO Party will prepare a forecast of the value to be used in the CC formula instead.

The CC value is calculated as a percentage, and rounded to two decimal places.

- $A_j$  = total cost (£) of asset “j” reinforcement in the considered Network Group over 10-year period
- $l$  = index of the total load level at which reinforcement of Branch “j” is required
- $C_l$  = total demand (kVA) of the Network Group, in the Maximum Demand Scenario, in the year  $Y_l$  in which reinforcement of Branch “j” is required
- $D$  = total demand (kVA) in the Network Group in the first year of the 10-year horizon in the Maximum Demand scenario
- $g_l$  = annual average load growth rate corresponding to the year in which the reinforcement is expected to be required (see below)
- $T$  = 10 years over which the reinforcement cost is recovered

- 9.3 The annual average load growth rate corresponding to the year in which the reinforcement is expected to be required generic Network Group load growth rate,  $g_l$ , is calculated by:

$$g_l = \frac{\ln\left(\frac{C_l}{D}\right)}{Y_l}$$

**Where:**

- $g_l$  = annual average load growth rate corresponding to the year in which the reinforcement is expected to be required
- $Y_l$  = number of years before the reinforcement of Branch “j” is required
- $C_l$  = total demand (kVA) of the Network Group, in the Maximum Demand Scenario, in the year  $Y_l$  in which reinforcement of Branch “j” is required
- $D$  = total demand (kVA) in the Network Group in the first year of the 10-year horizon in the Maximum Demand scenario

## Hybrid groups

9.4 This scenario necessitates that a hypothetical, hybrid Network Group, which represents a composite of the ‘parent’ groups, is constructed for the purpose of setting incremental charges. The demand and generation incremental charges for a hybrid Network Group should be calculated by aggregating the incremental charges of all constituent Network Groups weighted by the demands supplied to the downstream Network Group.

9.5 Consider the following:

- (a) a Primary Substation (Level 3) Network Group, PRY, that is supplied from two separate BSP (Level 2) Network Groups, BSP1 and BSP2;
- (b) transformers T1 and T3 at PRY are supplied from BSP1 and transformer T2 is supplied from BSP2. The power flows through T1, T2 and T3 are  $D_{PRYT1}$ ,  $D_{PRYT2}$  and  $D_{PRYT3}$  under Normal Running Arrangements; and
- (c) the incremental charge (Charge 1 ) associated with Network Group BSP1 is  $FCP_{BSP1}$  and the incremental charge associated with BSP2 is  $FCP_{BSP2}$ .

9.6 The incremental charge (Charge 1 ) for the hybrid ‘parent’ group supplying PRY is given by:

$$FCP_{hybrid} = \frac{\left( FCP_{BSP1} * (D_{PRYT1} + D_{PRYT3}) \right) + (FCP_{BSP2} * D_{PRYT2})}{D_{PRYT1} + D_{PRYT2} + D_{PRYT3}}$$

### Where:

- $FCP_{hybrid}$  = ‘hybrid’ parent group incremental charge
- $FCP_{BSP1}$  = incremental charge associated with Network Group BSP1
- $D_{PRYT1}$  = demand recorded at T1 at Primary Substation PRY
- $D_{PRYT3}$  = demand recorded at T3 at Primary Substation PRY
- $FCP_{BSP2}$  = incremental charge associated with Network Group BSP2
- $D_{PRYT2}$  = demand recorded at T2 at Primary Substation PRY

## ATTACHMENT 1 - CALCULATION OF NETWORK GROUP LOAD INCREMENTAL CHARGES – A SIMPLE EXAMPLE

1. A small network example is shown below (Figure 12) to illustrate the calculation of Network Group incremental charges for demand (load).
2. The shown network consists of a single GSP Network Group (Level 1 shown in red) that contains two BSP Network Groups (denoted as BSP\_A and BSP\_D shown in green) (Level 2). For the sake of simplicity and brevity the calculation is carried out assuming that the network is split only into Level 1 and Level 2 (ignoring Level 3) Network Groups. The calculation principles described in this example can be similarly ‘extended’ to Level 3 Network Groups.
3. There are five reinforcements identified for this small network through a power flow analysis discussed in section 7 (Power flow analysis process) of Annex 1. These reinforcements are: a 132 kV line between ‘GSPB10’ and ‘GENB10’ and two primary transformers in each Level 2 Network Group. The required reinforcements and the year when these would be required are shown in the figure below.

**Figure 12 - Example of charging by Network Groups**

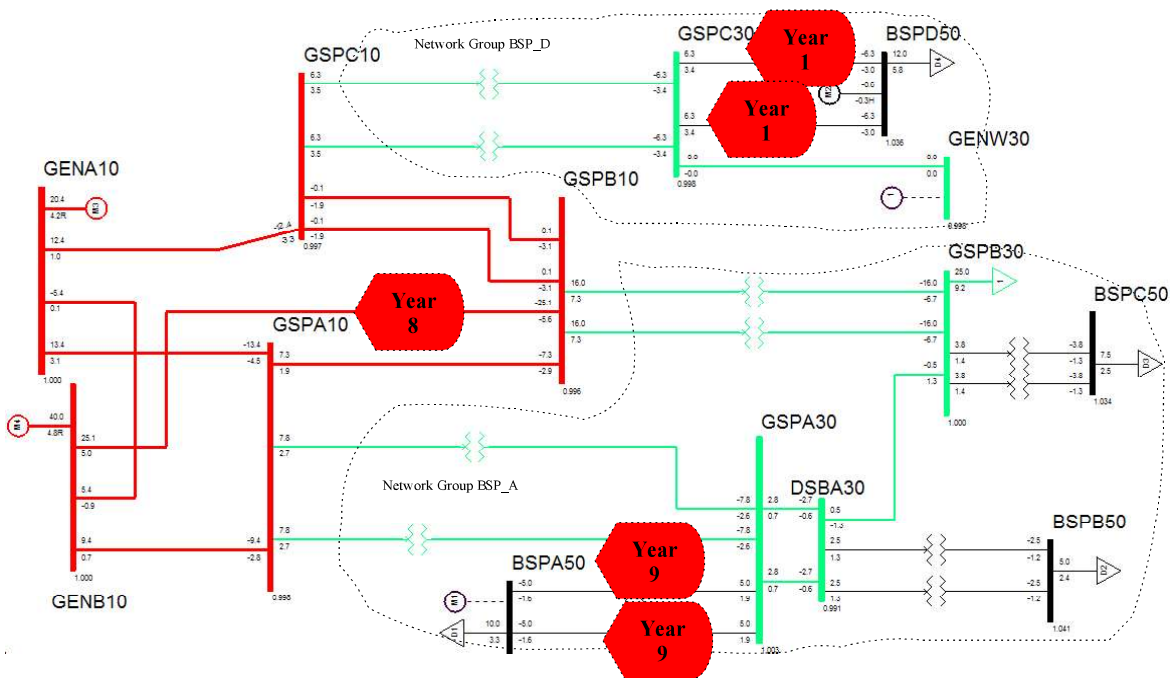

4. The calculation of Network Group incremental charges is summarised in (Table 8) for demand connected to 132 kV and in Table 8A for demand connected within BSP\_A and BSP\_D. The calculation is based on the formula given in paragraph 1.16 of the Authority's Decision Document (ref: 90/09, Annex 2):

$$FCP = i \left(\frac{A}{C}\right) \left(\frac{D}{C}\right)^{\frac{2i}{g}-1} / (1 - e^{-iT}) = 0.134786 * \left(\frac{A}{C}\right) \left(\frac{D}{C}\right)^{\frac{2i}{g}-1}$$

Where:

*i* is a discount rate,

*T* = 10 years,

*A* is the Branch reinforcement cost (£),

*C* is demand (MVA) of the Network Group at which each reinforcement would be required,

*D* is initial demand (MVA) in the Network Group and

*g* is demand growth rate calculated from the formulae given in Attachment 1 - Calculation of Network Group Load incremental charges – A Simple

Example, specifically  $\frac{\ln(\frac{C}{D})}{Y}$

where *Y* is the number of years into the future when reinforcement is required.

5. The implementation of the formula given above is described in a number of steps in Tables 8 and 8A below.
6. Both tables are split into two parts, the shaded one which contains information on:
- Network Group name;
  - Network Group incremental charge for reinforcements within the Network Group;
  - Network Group incremental charge for reinforcements in the parent Network Group;

- Total Network Group incremental charge;
- $C$  and  $D$ .

The second part (non-shaded) is a decomposition of the Network Group incremental charge with respect to each reinforcement, where a ‘reinforcement share’ in the Network Group incremental charge is calculated.

- The Network Group incremental charge for Level 1 Network Group is 3.24 £/kVA/annum due to the cost of the 132 kV reinforcement of £4,125,000.
- The Network Group incremental charges for Level 2 consist of the corresponding incremental charge due to reinforcements identified in the Network Group (BSP\_A 1.28 £/kVA/annum, BSP\_D 9.18 £/kVA/annum) and the incremental charge calculated for the corresponding higher level, which is 3.24 £/kVA/annum. The combined Network Group incremental charge for BSP\_A is a sum of 1.28 £/kVA and 3.24 £/kVA/annum, which is 4.52 £/kVA/annum. Similarly, for Network Group BSP\_D the combined Network Group incremental charge is 12.42 £/kVA/annum.

**Table 8 – Network Group incremental charge for Level 1 Network Group.**

Network Group	Network Group charge <sup>5</sup>	Higher Level charge <sup>5</sup>	Combine charge <sup>5</sup>	Demand[MVA]	Incremental charge decomposition				
					Branch Cost - $A$ [£]	Timing [years]	$\left(\frac{A}{C}\right)$	$\left(\frac{D}{C}\right)^{\frac{2i}{g}-1}$	Branch Share (footnote) [£/kVA/annum]
GSP	3.24	0	3.24	D=63.94 C=67.04 (Year 8)	4125000	8	61530	0.389	3.24

<sup>5</sup> Network Group charge, Higher level Network Group charge and Combined Network Group charge are given in £/kVA/annum.

**Table 8A - Network Group incremental charge for Level 2 Network Group.**

Network Group	Network Group charge <sup>4</sup>	Higher Level charge <sup>4</sup>	Combined charge <sup>4</sup>	Demand [MVA]	Incremental charge decomposition				
					Branch Cost - A[£]	Timing [years]	$\left(\frac{A}{C}\right)$	$\left(\frac{D}{C}\right)^{\frac{2i}{g}-1}$	Branch Share [£/kVA/annum]
BSP_A	1.28	3.24	4.52	D=50.6 C=52.6 (Year 9)	Branch Cost - A[£]	Timing [years]	$\left(\frac{A}{C}\right)$	$\left(\frac{D}{C}\right)^{\frac{2i}{g}-1}$	Branch Share [£/kVA/annum]
					727600	9	13832.7	0.345	0.64
					727600	9	13832.7	0.345	0.64
BSP_D	9.18	3.24	12.42	D=13.33 C=13.46 (Year 1)	Branch Cost - A[£]	Timing [years]	$\left(\frac{A}{C}\right)$	$\left(\frac{D}{C}\right)^{\frac{2i}{g}-1}$	Branch Share [£/kVA/annum]
					509200	1	37830.6	0.9	4.59
					509200	1	37830.6	0.9	4.59

### ATTACHMENT 3 - OUTPUT RESULTS

1. The final outputs of the work outlined in this Schedule are Network Group incremental charges for demand (load). These are not however the final Use of System Charges and further calculations under EDCM are required to derive the final Use of System Charges.
2. The output data listed in table 3 below are the minimum necessary for the calculation of the final EDCM Customer Use of System Charges. To 'link' Network Groups and Nodes representing demand (load) additional 'mapping' tables might be required.
3. It should be pointed out that the other information used to derive the output data will be retained for the interests of transparency.

**Table 3 – Output information required to calculate final EDCM Use of System Charge.**

Item	Item Name	Details
1	Network Group ID	Unique identifier of the Network Group
2	Charge 1: Demand (load) Use of System Charge (£/kVA/annum)	Network Group incremental charge for demand (load)
4	Parent ID	Identifier of the higher voltage Network Group immediately associated with the Network Group described by Item 1 <sup>6</sup>
5	Active Power (kW) of Demand (Load) for Maximum Demand Scenario.	The total kW demand (load) connected to the Network Group (negative value) in the Maximum Demand Scenario
6	Reactive Power (kVAr) of Demand (Load) for Maximum Demand Scenario	The total kVAr demand (load) connected to the Network Group in the Maximum Demand Scenario <sup>7</sup>

<sup>6</sup> Where there is no higher voltage Network Group associated with the Network Group described by Item 1 (i.e. it is a GSP level Network Group), then the Parent ID field should be left blank.

<sup>7</sup> Where the current calculated for demand lags its voltage the reactive power shall be allocated the same sign as the active power. Where the current calculated for demand leads its voltage the reactive power shall be allocated the opposite sign to the active power.

9	Active Power (kW) of Demand (Generation) for Maximum Demand Scenario	The total kW demand (generation) connected to the Network Group (positive value) in the Maximum Demand Scenario
10	Reactive Power (kVAr) of Demand (Generation) for Maximum Demand Scenario	The total kVAr demand (generation) connected to the Network Group in the Maximum Demand Scenario <sup>8</sup>

4. The demand (load) information that is provided as part of the output information (Active Power (kW) of Demand (Load) for Maximum Demand Scenario and Reactive Power (kVAr) of Demand (Load) for Maximum Demand Scenario) shall be determined by summation of the demands (load) modelled at all Nodes within the Network Group and any associated lower voltage Network Group(s).
5. The demand (generation) information that is provided as part of the output information (Active Power (kW) of Demand (Generation) for Maximum Demand Scenario and Reactive Power (kVAr) of Demand (Generation) for Maximum Demand Scenario) shall be determined by summation of the demands (generation) modelled at all Nodes within the Network Group and any associated lower voltage Network Group(s).

## SCHEDULE 17 – EHV DISTRIBUTION CHARGING METHODOLOGY (FCP MODEL)

### ANNEX 2 - DERIVATION OF FCP CHARGING FORMULAE

The basis of the Forward Cost Pricing (FCP) methodology for demand is to set incremental charges so as to recover the expected reinforcement costs from the contributing demand over the 10-year period prior to the forecast time of reinforcement. The revenue is assumed to be invested at the discount rate. Costs and incremental charges are determined for each Network Group separately. The charging formulae below are first derived for the reinforcement of a single asset (Branch). The final incremental charge rates result from the reinforcement costs of several assets, the cost being apportioned between the Network Group in which the reinforcement is forecast and the Network Groups at lower voltage levels connected to this Network Group.

#### **Demand charging formula**

Consider an asset subject to a current demand  $D$  in kVA where  $D$  grows continuously at a rate of  $g$ :

$$D(t) = D \cdot \exp(g \cdot t). \quad (1)$$

Suppose reinforcement would be required when the demand reaches a capacity of  $C$  (kVA), i.e.  $D(t)=C$ . Then the time  $t$  till reinforcement is required is given by:

$$t = \ln(C/D) / g. \quad (2)$$

Assume a discount rate of  $i$ , then applying the discount rate continuously (rather than in annual increments) to asset cost  $A$  gives a present value of the asset of:

$$PV = A \cdot \exp(-i \cdot t). \quad (3)$$

The marginal change in PV with respect to the demand  $D$  is given by differentiating expression (3), applying chain rule and using expression (2):

$$\frac{dPV}{dD} = \frac{dPV}{dt} \frac{dt}{dD} = -i \cdot A \cdot \exp(-i \cdot t) \cdot \left[ \frac{1}{g(C/D)} (-CD^{-2}) \right] = (i/g)(A/D)\exp(-i \cdot t). \quad (4)$$

To obtain an annual rate (£/kVA/annum) the marginal charge in £/kVA needs to be annuitised. There is no unique way of calculating the annuity factor as new payments are

calculated each year. One solution is to assume NPV approach, that is, apply continuous discounting factor, and spread the incremental charge over the total time T between reinforcements (during which reinforcement incremental charges may be levied). The “annuity factor”  $\alpha$  is then calculated as:

$$\alpha = \exp(-i \cdot t) / T, \quad (5)$$

and the annuitised marginal charge is obtained by multiplying (4) and (5):

$$p(t) = (i / g)(A / D) \exp(-2i \cdot t) / T \text{ £ / kVA / annum.} \quad (6)$$

The basic principle of the FCP approach is to ensure that the total revenue recovered over the 10 year period prior to reinforcement is equal to the cost of reinforcement. The total recovered revenue is calculated by multiplying the annuitised marginal charge by demand and revaluing to the time of reinforcement (i.e. applying the continuous “future value” factor):

$$\int_0^{T=10} p(t) \cdot D \cdot \exp(it) dt, \quad (7.1)$$

which gives upon substitution of expression (6):

$$\int_0^{T=10} (i / g)(A / D) \exp(-2i \cdot t) / T \cdot D \cdot \exp(it) dt = \frac{A}{gT} [1 - \exp(-10i)]. \quad (7.2)$$

The total recovered cost (7.2) shall be equal to asset cost A, so the marginal charge (6) needs to be scaled by factor  $[1 - \exp(-10i)] / gT$  first and then time t from expression (2) substituted giving the FCP demand formula:

$$FCP_{load} = i(A / D) \exp(-2it) / [1 - \exp(-10i)] = i(A / D) \exp[-2i \cdot \ln(C / D)^{1/g}] / [1 - \exp(-10i)] = i(A / C)(D / C)^{2i/g-1} / [1 - \exp(-10i)] \text{ £ / kVA / annum.}$$

In

applying this formula to a reinforcement within a Network Group, C refers to the total kVA

within the Network Group at which reinforcement would be required and similarly D refers to the current total kVA within the Network Group across which the cost is shared.

Each Network Group is studied over the planning period of 10 years and several reinforcements are likely to be required. The demand charging formula can then be written for the Network Group as:

$$FCP_{load} = \sum_j i \left( \frac{A_j}{C_l} \right) \left( \frac{D}{C_l} \right)^{\frac{2i}{g_i} - 1} / (1 - e^{-iT}) \text{ £ / kVA / annum ,} \quad (9)$$

where:

- $j$  is index of Branch asset whose reinforcement is required in the planning period;
- $i$  is the discount rate, which is set to equal the latest pre-tax real weighted average cost of capital (CC below) for each DNO Party calculated using the following formula:

$$CC = (\text{Gearing Assumption} \times \text{Pre-Tax Cost of Debt}) + (1 - \text{Gearing Assumption}) \times (\text{Post Tax Cost of Equity} / (1 - \text{Corporation Tax Rate}))$$

where:

Gearing Assumption is set to the 'Notional gearing' value for the regulatory year for which tariffs are being set in the latest version of the PCFM (InputSummary sheet, Finance inputs, Vanilla allowed return on capital) prepared for the relevant DNO Party for publication with such tariff setting on the DNO Party's website;

Pre-Tax Cost of Debt is set to the 'Allowed return on debt' value for the regulatory year for which tariffs are being set in the latest version of the PCFM (InputSummary sheet, Finance inputs, CAPM calculator tool: allowed return on debt) prepared for the relevant DNO Party for publication with such tariff setting on the DNO Party's website;

Post Tax Cost of Equity is set to the ‘Allowed return on equity’ value for the regulatory year for which tariffs are being set in the latest version of the PCFM (InputSummary sheet, Finance inputs, CAPM calculator tool: allowed return on equity) prepared for the relevant DNO Party for publication with such tariff setting on the DNO Party’s website; and

Corporation Tax Rate is set to the ‘Corporation tax rate’ value for the regulatory year for which tariffs are being set in the latest version of the PCFM (InputSummary sheet, Tax, Tax policy) prepared for the relevant DNO Party for publication with such tariff setting on the DNO Party’s website.

In the event of any value not being available from the above data sources, the DNO Party will prepare a forecast of the value to be used in the CC formula instead.

The CC value is calculated as a percentage, and rounded to two decimal places.

- $A_j$  is the total cost (£) of asset  $j$  reinforcement in the considered Network Group;
- $l$  is index of the total load level at which reinforcement of asset  $j$  is required;
- $C_l$  is total demand (kVA) of the Network Group in the year  $Y_l$  in which reinforcement of asset  $j$  is required;
- $D$  is initial total demand (kVA) in the Network Group;
- $g_l$  is demand growth rate calculated from  $\frac{\ln(C_l / D)}{Y_l}$  where  $Y_l$  is the number of years into the future when reinforcement of asset  $j$  is required;
- $T$  is the 10 year period over which the reinforcement cost is recovered.