

SCHEDULE 18 – EHV CHARGING METHODOLOGY (LRIC MODEL)

This Schedule 18, version 14.1, is to be used for the calculation of Use of System Charges which will become effective from, 01 April 2022 and remain effective until superseded by a revised version.

1. INTRODUCTION

1.1 This Schedule 18 sets out one, of the two, EHV Distribution Charging Methodologies (EDCM). The other EDCM is set out in Schedule 17.

1.2 This Schedule 18 sets out the methods, principles, and assumptions underpinning the EDCM for the calculation of Use of System Charges by the DNO Parties with the following Market Domain I.D.s:

EELC;

NORW;

LOND;

NEEB;

YELG;

SEEB;

SWAE; and

SWEB.

1.3 In order to comply with this methodology statement when setting distribution Use of System Charges the DNO Parties referred to above will populate the following EDCM model versions:

(a) For charges effective from 1 April 2020:

- (i) where the Authority has given no direction under Clause 19.1B, EDCM model version LRIC v3 as issued by the Panel in accordance with Clause 14.5.3; or
 - (ii) for charges effective from 1 April 2020 where the Authority has given direction under Clause 19.1B that periods of notice described in Clause 19.1A need not apply, EDCM model version LRIC v3 (332) as issued by the Panel in accordance with Clause 14.5.3;
- (b) for charges effective from 1 April 2021:
- (i) where the Authority has given no direction under Clause 19.1B, EDCM model version LRIC v7 as issued by the Panel in accordance with Clause 14.5.3: or
 - (ii) where the Authority has given direction under Clause 19.1B that periods of notice described in Clause 19.1A need not apply, EDCM model version LRIC v7(379) as issued by the Panel in accordance with Clause 14.5.3; or
- (c) for charges effective from 1 April 2022 or later:
- (i) where the Authority has given no direction under Clause 19.1B, EDCM model version LRIC v9 as issued by the Panel in accordance with Clause 14.5.3; or
 - (ii) where the Authority has given direction under Clause 19.1B that periods of notice described in Clause 19.1A need not apply, EDCM model version LRIC v10 as issued by the Panel in accordance with Clause 14.5.3.

Main steps

1.4 The EDCM involves four main steps.

1.5 Step 1 is the application of load flow techniques and the LRIC or FCP methodologies to determine an EDCM tariff element, known as Charge 1, which represents costs associated with demand-led reinforcement, estimated by reference to power flows in the maximum demand scenario.

- 1.6 Step 2 involves the allocation of DNO Party costs to Connectees using appropriate cost drivers.
- 1.7 Step 3 adds a scaling element to charges which is related to Allowed Revenue.
- 1.8 Step 4 uses CDCM charges to determine the element of portfolio charges to be applied in the case of DNO/IDNO Parties who are supplied from the DNO Party's network at voltages higher than the scope of CDCM charges.
- 1.9 Figure 1 provides a diagrammatic overview of the steps involved for import charges.

Figure 1 Diagrammatic overview of the EDCM for import

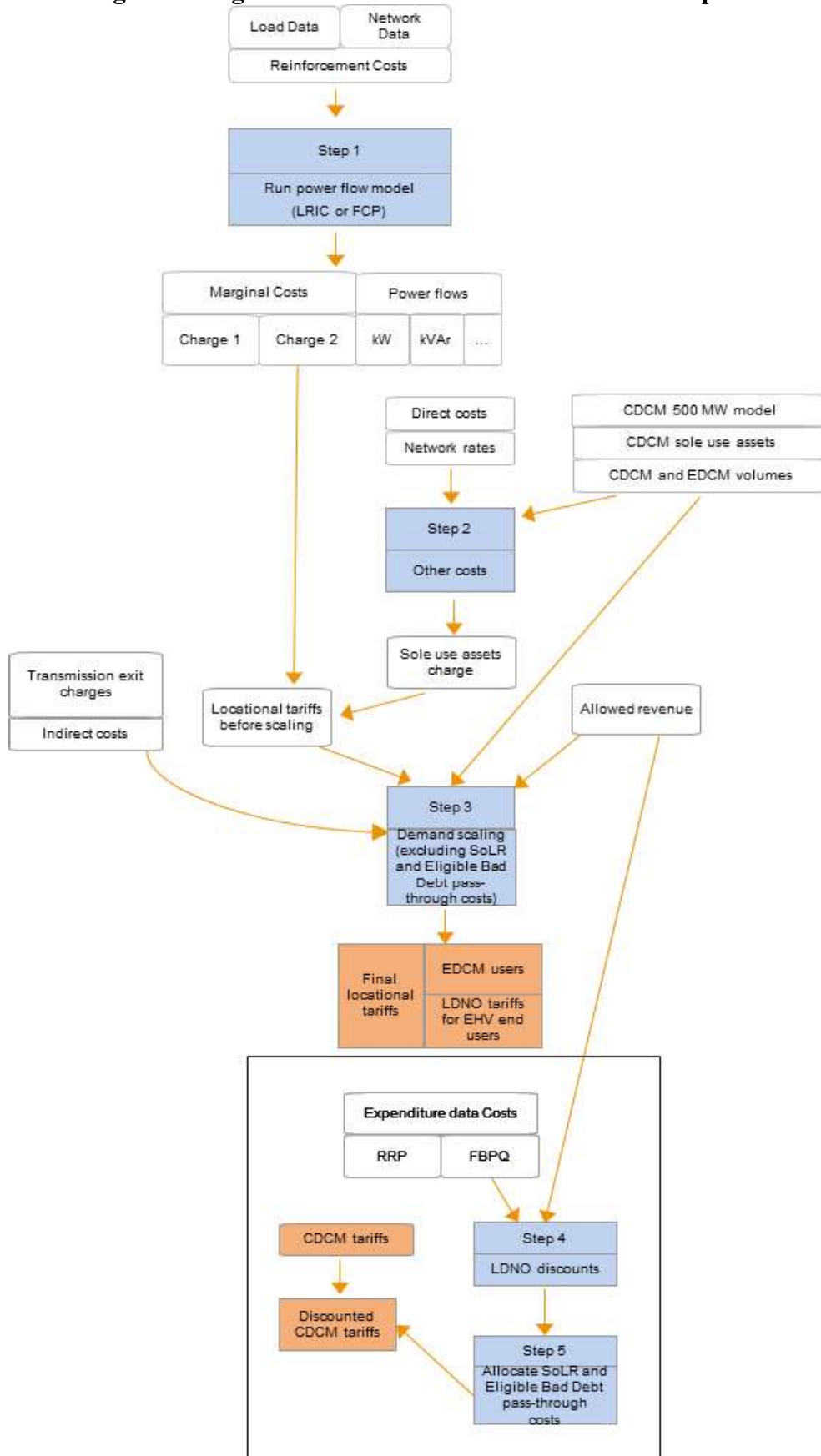

2. LONG RUN INCREMENTAL COST PRICING ANALYSIS

Introduction

- 2.1 This Schedule 18 sets out the principles and high-level detail that should be adopted as the common approach to EDCM Use of System Charging that is based on the Long Run Incremental Cost (LRIC) model.
- 2.2 The LRIC model calculates Nodal incremental costs. These costs represent the brought forward (or deferred) reinforcement costs caused by the addition of an increment of demand or generation at each network Node. The method models the impact changes in Connectees' behaviour have on network costs.
- 2.3 In particular, the LRIC model takes account of the effects a change in Connectee behaviour has on the network by using AC power flow analysis, which enables the calculation of the time needed before elements of the network require reinforcement and subsequently the net present value (NPV) of the future costs of reinforcement. The incremental cost is equal to the difference in the NPV of reinforcing under existing conditions and when an increment of new demand or generation is added.
- 2.4 To calculate Use of System Charges for EDCM Connectees (demand and generation), the common LRIC method consists of the following stages:
- (a) LRIC model:
 - (i) AC power flow analysis;
 - (ii) calculation of Branch incremental costs (in £/annum); and
 - (iii) calculation of Nodal incremental costs (including the consideration of the Maximum Demand Scenario and the Minimum Demand Scenario; in £/annum);
 - (iv) calculation of Nodal, Charge 1 (by taking account of the magnitude of the increment driving the incremental costs; in £/kVA/annum).

- (b) derivation of site-specific Use of System Charges (including the consideration of sole use asset charges, transmission exit charges and operating and maintenance costs); and
- (c) scaling to derive the final EHV Use of System Charges.

Power Flow Analysis

- 2.5 Power flow analysis calculates the effects of adding an increment of demand or generation to the DNO Party's Distribution System. In particular, it calculates the power flows passing over the various assets comprising the DNO Party's network under base and incremented conditions using maximum (typically during the winter period) and minimum (typically during the summer period) demand data.
- 2.6 The power flow analysis calculates the following values for each Node/Branch combination:
- (a) base power flows using Maximum Demand Data and Minimum Demand Data, and
 - (b) incremented power flows using Maximum Demand Data and Minimum Demand Data.
- 2.7 Power flow analysis uses a number of processes and assumptions as follows:
- (a) A representation of the entire EHV network captured using appropriate power flow modelling software (the **Authorised Network Model**)⁸. The modelled network should be based on the network expected to exist and be in operation in the Regulatory Year that Use of System Charges are being calculated for, based on the DNO Party's Long Term Development Statement (save that, until 5 November 2016, where charges are being calculated for two or more Regulatory Years, the same Authorised Network Model will be used for all the years).

⁸ Guidance on creation of a suitable network model is provided in section 4 Authorised Network Model of Annex 1.

- (b) AC power flows should be calculated for maximum and minimum demand base conditions and for maximum and minimum demand conditions plus an increment of demand or generation⁹. A 0.1MW Nodal increment should be used in relation to calculating the active demand and generation elements of the incremented power flows, assuming that the power factor is 0.95 for increments applied at Nodes where demand is located and unity for increments applied at Nodes where generation is located. Increments will be applied in the direction of demand for the analysis of maximum demand network conditions and in the direction of generation for the analysis of minimum demand conditions. Where both demand (load) and generation are located at a Node, separate incremental power flows shall be calculated using increments at 0.95 power factor and at unity power factor.
- (c) Nodal demand and generation data should be used, which is based on actual metered network usage data that is recovered from the DNO Party's Supervisory Control and Data Acquisition (SCADA) (or equivalent) system. In particular:
- (i) **Demand Data** – for the maximum demand period, the model uses demands consistent with those used to assess reinforcement¹⁰. This includes diversity to allow a complete EHV network model to be run¹¹. Minimum demands are taken as being a percentage of maximum demands¹². This percentage is derived for each Grid Supply Point (GSP) and applied to the demands supplied by that GSP;

⁹ Guidance on the power-flow analysis required to consider these conditions is provided in sections 6.3 and 6.10 of Annex 1.

¹⁰ Guidance on the demand data required to represent the maximum demand period is provided in section 5.31 of Annex 1.

¹¹ Guidance on the application of diversity to demand data is provided in section 5.11 of Annex 1.

¹² Guidance on the demand data required to represent the minimum demand period is provided in section 5.37 of Annex 1.

- (ii) **Generation Data** – for the maximum demand period generation is zero unless it is deemed to contribute to network security in accordance with ER P2/6¹³. The generation export used for the minimum demand period is the Maximum Export Capacity for each EDCM (Generation) Connectee, factored to reflect coincidence with other generation export. This factor is derived for each GSP and applied to EDCM (Generation) Connectees connected to that GSP. These are broadly similar to the assumptions that are used by the DNO Party when investment planning¹⁴;
- (iii) **Cleansing Data** – the DNO Party should cleanse demand and generation data so that it is representative of typical network usage. That is, anomalous power flows, which represent, for example, demand levels at a time when the network is experiencing an outage, should be removed from the data set and the effects of load management schemes should be taken account of¹⁵;
- (iv) **GrowthRate** – a single underlying network growth rate is used to assess the timing of future reinforcement for both demand and generation Connectees. It represents the long run growth of all DNO Parties' networks and is set to 1% growth per annum. To facilitate predictability and stability, the growth rate is used throughout the model, and (as with all assumptions) the DNO Party should keep this growth rate under review. As a minimum, the rate should be reviewed and reset when the charge restriction conditions in the DNO Party's Distribution Licence are reviewed every five years; and

¹³ Guidance on the generation data required to represent the maximum demand period is provided in section 5.31 of Annex 1.

¹⁴ Guidance on the generation data required to represent the minimum demand period is provided in section 5.37 (of Annex 1

¹⁵ Guidance on suitable cleansed demand data is provided in section 5.2 of Annex 1

- (v) **Security Factors** – a pair of Security Factors should be determined¹⁶ for each Branch using a full N-1 Contingency Analysis assuming maximum and minimum demand conditions¹⁷. These factors are used to determine the usable capacity of network Branches during maximum and minimum demand conditions. They are recalculated each time the network is changed or new load estimates used. Each N-1 Contingency will consider the consequential network actions and where appropriate constraints on Connectee demands (both generation and load) to meet the security of supply requirements of E/R P2/6.
- (d) The results of the power flow analysis are sense checked to identify where application of Security Factors to the incremented power flows leads to excessively large (and non-credible) estimations of the change in Branch utilisation. The following conditions are identified:
 - (i) low base power flows;
 - (ii) high Security Factors; and
 - (iii) where the difference between the base and incremented Branch power flows exceeds the change that could reasonably be expected to occur as a result of the application of an increment of demand or generation.
- (e) Where such cases are encountered a modified approach to the anticipated change in power flow in the Branch is used. Guidance on the sense checking of the power flow analysis results is provided in section 8.3 of Annex 1. This approach does not apply the Security Factor when considering the change in flow between the incremented and the base case power flow.

Calculation of Branch incremental costs

¹⁶ Guidance on the derivation of Security Factors is provided in section 6.6 of Annex 1.

¹⁷ Guidance on the Contingency Analysis used in the derivation of Security Factors is provided in section 6.4 of Annex 1.

2.8 The incremental cost of reinforcing a Branch due to an increment at a Node is the difference in the net present value (NPV) of reinforcing the Branch under base and incremented conditions. An explanation of the derivation of the formulae used to calculate Branch incremental costs is provided in Annex 2.

2.9 The Branch incremental cost, denoted ΔC_i , is calculated using the following formulae:

$$\Delta C_i = [NPV(inc) - NPV(base)]_i \cdot AnnuityRate$$

$$NPV(inc) = \frac{CostOfReinforcementSolution}{[1 + DiscountRate]^{YearsToReinforcement(inc)}}$$

$$NPV(base) = \frac{CostOfReinforcementSolution}{[1 + DiscountRate]^{YearsToReinforcement(base)}}$$

$$YearsToReinforcement(base) = \frac{\log(BranchCapacity) - \log(BasePowerFlow(MVA))}{\log(1 + GrowthRate)}$$

$$YearsToReinforcement(inc) = \frac{\log(BranchCapacity) - \log(IncPowerFlow(MVA))}{\log(1 + GrowthRate)}$$

$$AnnuityRate = \frac{DiscountRate}{1 - \left[\frac{1}{(1 + DiscountRate)^{AnnuityPeriod}} \right]}$$

BranchCapacity is the MVA rating of the “critical” asset in the considered Branch divided by the corresponding Security Factor; a pair of Branch capacities is calculated for maximum demand and minimum demand conditions. Guidance on Branch ratings is provided in section 7.5 of Annex 1. Guidance on sense checking Security Factors prior to the calculation of Branch incremental costs is provided in section 8.3 of Annex 1.

CostOfReinforcementSolution is the modern equivalent asset value (MEAV) of reinforcing the particular Branch, bearing in mind the requirements of similar historic projects. This cost is the same under both base and incremented conditions. The DNO Party should use the specifications and costs of similar, past reinforcement projects as a means for determining the requirements and costs of a particular future reinforcement project. Guidance on the reinforcement cost calculation principles is provided in section 7.4 of Annex 1.

YearsToReinforcement is the number of years into the future when reinforcement of the Branch will be required. This is calculated separately under base and incremented conditions.

DiscountRate is set to equal the latest pre-tax real weighted average cost of capital (CC below) for each DNO Party calculated using the following formula:

$$CC = (\text{Gearing Assumption} \times \text{Pre-Tax Cost of Debt}) + (1 - \text{Gearing Assumption}) * (\text{Post Tax Cost of Equity} / (1 - \text{Corporation Tax Rate}))$$

where:

Gearing Assumption is set to the ‘Notional gearing’ value for the regulatory year for which tariffs are being set in the latest version of the PCFM (InputSummary sheet, Finance inputs, Vanilla allowed return on capital) prepared for the relevant DNO Party for publication with such tariff setting on the DNO Party’s website;

Pre-Tax Cost of Debt is set to the ‘Allowed return on debt’ value for the regulatory year for which tariffs are being set in the latest version of the PCFM (InputSummary sheet, Finance inputs, CAPM calculator tool: allowed return on debt) prepared for the relevant DNO Party for publication with such tariff setting on the DNO Party’s website;

Post Tax Cost of Equity is set to the ‘Allowed return on equity’ value for the regulatory year for which tariffs are being set in the latest version of the PCFM (InputSummary sheet, Finance inputs, CAPM calculator tool: allowed return on equity) prepared for the relevant DNO Party for publication with such tariff setting on the DNO Party’s website; and

Corporation Tax Rate is set to the ‘Corporation tax rate’ value for the regulatory year for which tariffs are being set in the latest version of the PCFM (InputSummary sheet, Tax, Tax policy) prepared for the relevant DNO Party for publication with such tariff setting on the DNO Party’s website.

In the event of any value not being available from the above data sources, the DNO Party will prepare a forecast of the value to be used in the CC formula instead.

The CC value is calculated as a percentage, and rounded to two decimal places.

GrowthRate is the growth rate in per units of the power flow, currently set at 1%.

AnnuityPeriod is the period over which costs are annuitised. This period is set to 40 years and represents the typical life of an asset.

- 2.10 Separate assessment of the total Branch cost recovery associated with incremental costs that represent charges, *PositiveCostRecovery*, and the total Branch recovery associated with incremental costs that represent credits, *NegativeCostRecovery*, is done to eliminate over-recovery of both the charges and credits.
- 2.11 Two total Branch cost recoveries, namely *PositiveCostRecovery* and *NegativeCostRecovery*, are derived from the power-flow modelling and sense checked for each Branch individually. Guidance on sense checking of overall positive and negative Branch cost recoveries is provided in section 8.3 of Annex 1.
- 2.12 The positive Branch cost recovery for a particular Branch is calculated by adding together the cost recovery for the Branch at each Node where the incremental cost is positive (i.e. ‘charge’, determined by the product of the positive Branch incremental costs and the appropriate Nodal demands, or generation output, used in the modelled network).
- 2.13 Similarly, the negative Branch cost recovery is calculated for the Branch where each Node incremental cost is negative (i.e. ‘credits’, determined by the product of the negative Branch incremental costs and the appropriate Nodal demands, or generation output, used in the modelled network).
- 2.14 Both sense checks only consider Branch incremental costs associated with the period that drives reinforcement. Where either the positive or the negative (by absolute value) cost recovery for a particular Branch is greater than the actual reinforcement cost of the Branch (*ActualReinforcementCost*, as determined by the product of the Annuity Rate and the *CostofReinforcementSolution*), then it is considered that the Branch recovery of charges or credits is excessive.
- 2.15 In order to limit the level of positive Branch cost recovery (charges) to being no greater than the actual reinforcement cost of the Branch, a Positive Cost Recovery Factor, S_{Pi} , is applied to the positive Branch incremental costs associated with Branch i, when used in the calculation of Nodal incremental costs. Similarly, a Negative Cost Recovery

Factor, s_{Ni} , is applied to the negative Branch incremental costs associated with Branch i in order to limit the level of negative Branch cost recovery (credits).

- 2.16 Where the positive cost recovery associated with Branch i (ie charges) is determined by the sense checking, to be excessive then:-

$$s_{Pi} = \text{ActualReinforcementCost}_i / \text{PositiveCostRecovery}_i$$

otherwise:-

$$s_{Pi} = 1$$

Where the negative cost recovery associated with Branch i (i.e. credits) is determined to be excessive, then:-

$$s_{Ni} = \text{ActualReinforcementCost}_i / \text{NegativeCostRecovery}_i$$

$$s_{Ni} = 1.$$

- 2.17 The EHV network includes single Connectees using sole-use assets that have been sized to their connection requirements. Costs for these assets should be excluded from the calculation of incremental costs. Replacement and operation and maintenance costs for these assets should also be excluded from the calculation of incremental costs, but may be incorporated into a Connectee's final Use of System Charge.

Calculation of Nodal incremental costs

2.18 Guidance on the calculation of Nodal incremental costs, is provided in section 8 (Output results) of Annex 1. The formulae used to calculate Nodal incremental costs are described in Annex 2.

2.19 A pair of incremental costs (one for the Maximum Demand Scenario and another for the Minimum Demand Scenario) is calculated for each Node by summing Branch incremental costs that result from applying an increment at that Node. A peak Nodal incremental cost is calculated by summing Branch peak incremental costs, where maximum demand conditions drive Branch reinforcement. An off-peak Nodal incremental cost is calculated by summing Branch off-peak incremental costs, where minimum demand conditions drive Branch reinforcement. Only Branches that experience a change greater than both 1kVA and 0.01 % of Base Power Flow in the power that flows across them are used in the calculation of Nodal charges. The period that is deemed to drive reinforcement is the period with the highest absolute incremental cost.

2.20 The formulaic expression for Nodal incremental cost is given by:

$$IncrementalCostAtNode^{Peak} = \sum_{i \in \alpha} s_i \cdot \Delta C_i^{Peak}, \alpha = \{1, 2, \dots, B \mid |\Delta C_i^{Peak}| > |\Delta C_i^{Off-Peak}|\}$$

$$IncrementalCostAtNode^{Off-Peak} = \sum_{i \in \beta} s_i \cdot \Delta C_i^{Off-Peak}, \beta = \{1, 2, \dots, B \mid |\Delta C_i^{Peak}| < |\Delta C_i^{Off-Peak}|\}$$

where

$$\Delta C_i^{Peak} = [NPV(inc) - NPV(base)]_i^{Peak} \cdot AnnuityRate$$

$$\Delta C_i^{Off-Peak} = [NPV(inc) - NPV(base)]_i^{Off-Peak} \cdot AnnuityRate$$

ΔC_i^{Peak} and $\Delta C_i^{Off-Peak}$ denote the incremental cost of reinforcing Branch i , under maximum and minimum demand conditions respectively, due to an increment of demand or generation at the Node;

s_i denotes the Recovery Factor for Branch i ;

B is the total number of Branches in the network;

α and β are subsets of Branches where relevant conditions are satisfied.

Calculation of Nodal marginal charges for demand

2.21 Guidance on the calculation of Nodal marginal charges for demand sites is provided in section 8.12 (Demand Nodes) of Annex 1.

2.22 The Nodal incremental costs for demand sites are derived using Branch incremental costs produced by application of 0.1MW increments at 0.95 power factor, which is equivalent to 0.10526MVA. The Nodal marginal charges for demand in (£/kVA/annum) are obtained by dividing the Nodal incremental cost for each period by the absolute value of the kVA increment:

$$ChargeAtNode^{Peak} = IncrementalCostAtNode^{Peak} / 105.26 \text{ (£/kVA/annum)}$$

2.23 A positive value of $ChargeAtNode^{Peak}$ represents a charge for demand sites at the Node, whereas a negative value represents a credit. This statement defines the sign convention of the Nodal marginal charges (as outlined in section 8 (Output results) of Annex 1 and Attachment 3 (Output results) to Annex 1. However, it should be noted that this does not describe the application of these charges in the calculation of final Use of System Charges (or credits in respect of final Use of System Charges).

Generation sites

2.24 Guidance on the calculation of Nodal marginal charges for generation sites is provided in section 8.13 (

- 2.25 Generation Nodes) of Annex 1.
- 2.26 The Nodal incremental costs for generation sites are derived using Branch incremental costs produced by application of 0.1MW increments at unity power factor being equal to 0.1MVA. The Nodal marginal charges for generation are obtained by dividing the Nodal incremental cost for each period by the absolute value of the kVA increment:

$$ChargeAtNode^{Peak} = IncrementalCostAtNode^{Peak} / 100 \text{ (£/kVA/annum)}$$

- 2.27 A positive value of $ChargeAtNode^{Peak}$ represents a credit for generation sites at the Node, whereas a negative value represents a charge. This statement defines the sign convention of the Nodal marginal charges (as outlined in section 8 (Output results) of Annex 1 and Attachment 3 (Output results) to Annex 1. However, it should be noted that this does not describe the application of these charges in the calculation of final Use of System Charges (or credits in respect of final Use of System Charges).

Decomposition of Nodal marginal charges

- 2.28 Each Nodal marginal charge, derived from the Nodal incremental costs, is decomposed into two sub-elements, termed ‘local’ and ‘remote’, such that:-

$$ChargeAtNode^{Peak} = LocalChargeAtNode^{Peak} + RemoteChargeAtNode^{Peak}$$

- 2.29 The local element of each charge at a Node is derived from:-
- (a) the Branch incremental costs associated with Branches that are operating at the same nominal voltage as the voltage of the Node where the increment was applied; and
 - (b) the Branch incremental costs associated with Branches that represent transformation from a higher voltage down to the same nominal voltage as the voltage of the Node where the increment was applied.
- 2.30 The remote element of each Nodal incremental cost is derived from the Branch incremental costs from all Branches other than those where the Branches are operating at the same nominal voltage as the voltage of the Node where the increment was applied, or where the Branches represent transformation from a higher voltage down to

the same nominal voltage as the Node. In other words, all Branches that are not ‘local’ are ‘remote’.

Outputs from LRIC Analysis

2.31 The LRIC methodology produces the following outputs:

- (a) Location (Node);
- (b) Demand Type (Generation or Load);
- (c) Local Charge 1: $\text{LocalChargeAtNode}^{\text{peak}}$ (£/kVA/annum);
- (d) Remote Charge 1: $\text{RemoteChargeAtNode}^{\text{peak}}$ (£/kVA/annum);
- (e) Active Power (kW) for the Maximum Demand Scenario;
- (f) Reactive Power (kVAr) for the Maximum Demand Scenario;

3. EDCM CHARGE COMPONENTS FOR CONNECTEES

3.1 This section sets out the different charge components that will apply to Connectees under the EDCM. Charge components are the outputs of the EDCM and make up the distribution use of system charges applied to Connectees.

3.2 In the EDCM, each set of charges comprises import rates, export rates, or both, as applicable to the Connectee. The DNO Party’s Relevant Charging Statement includes information that enables a Supplier to determine which Designated EHV Property each set of charges applies to.

3.3 Demand charges under the EDCM comprise the following individual components:

Import fixed charges.

Import capacity charges.

Exceeded import capacity charges.

Unit rate charges for consumption at the time of the DNO Party’s peak (super-red time band).

3.4 The EDCM charge components for import are listed in Table 3.4.

Table 3.4 Charge components for import

Tariff component	Unit
Import fixed charge	p/day
Import capacity charge	p/kVA/day
Exceeded import capacity charge	p/kVA/day
Super-red import unit charge	p/kWh

3.5 Generation charges under the EDCM comprise the following individual components:

Export fixed charges

Export capacity charges

Exceeded export capacity charges

Export super-red unit rate (credit)

3.6 The EDCM charge components for export are listed in Table 3.6.

Table 3.6 Charge components for export

Charge component	Unit
Export fixed charge	p/day
Export capacity charge	p/kVA/day
Exceeded export capacity charge	p/kVA/day
Export super-red unit rate	p/kWh

3.7 The next section details the calculation of the elements that determine the charge components described above.

4. CALCULATION OF EDCM CHARGE COMPONENTS

- 4.1 EDCM charge components are derived from charge elements. This section describes the method for calculating each of these charge elements.

5. CHARGEABLE EXPORT CAPACITY FOR EXPORT CHARGES

- 5.1 The Chargeable Export Capacity for each Connectee is defined as the Maximum Export Capacity minus any capacity that is exempt from use of system charges in the charging year.

6. APPLICATION OF LRIC CHARGE 1

- 6.1 Each tariff in the model is linked to one LRIC location or point. Each LRIC point may have a local and remote charge 1 in £/kVA/year associated with it.
- 6.2 Some LRIC points might be designated as linked. Each set of linked points comprises a maximum of eight points. Where a tariff is associated with a point which is part of a set of linked points, the LRIC charge 1 used for that tariff are determined by calculating the applicable local and remote charge 1 as a weighted average of the local and network charge 1 respectively at each linked point (ignoring negative values) using the kVA modelled flow in the maximum demand run as weights. If all the weights are zero in any of these calculations then an unweighted average is used instead of the weighted average.
- 6.3 The import charges for the application of charge 1, is given by the formulas:

$$[\text{p/kWh super-red rate}] = (([\text{remote charge 1 } \text{£/kVA/year}] / \text{PF}) / [\text{number of hours in the super-red time band in a year}]) * 100$$

$$[\text{p/kVA/day capacity charge}] = ([\text{local charge 1 } \text{£/kVA/year}] / [\text{days in Charging Year}]) * 100$$

Where:

PF is the power factor of the flow at the point at which the customer is attached in the maximum demand scenario. This is calculated as - [Active power flow] /

$(\text{SQRT}([\text{Active power flow}]^2 + [\text{Reactive power flow}]^2))$. If either the numerator or denominator in calculation of the power factor is zero, the PF is replaced with 1. If the active power flow is generation-dominated, then PF is replaced with 1.

- 6.4 If the Connectee is attached to a cluster of linked locations, the sums of active power flows and reactive power flows at each location are used to calculate PF.
- 6.5 Charge 1 is applied to export charges as a credit. The credit is expressed as a negative charge rate in p/kWh and is applied in respect of active power units exported during the DNO Party's super-red time band. The credit rate is set to zero for Connectees who are assigned an F Factor of zero. The credit rate is calculated as follows:

$$[\text{p/kWh super-red export rate}] = -100 * [\text{Proportion eligible for charge 1 credits}] * ([\text{local charge 1 } \text{£/kVA/year}] + [\text{remote charge 1 } \text{£/kVA/year}]) * ([\text{Chargeable export capacity}] / [\text{Maximum export capacity}]) / [\text{number of hours in the super-red time band}]$$

Where:

The proportion eligible for charge 1 credits is zero if the F factor that is assigned to the Connectee as described in the LRIC methodology is equal to zero, and 1 otherwise.

The super-red export rate is not applied to Connectees with zero Chargeable Export Capacity.

7. NO APPLICATION OF NEGATIVE CHARGES

- 7.1 Under LRIC, charge 1 can be negative at some locations. Any negative values of Charge 1 (both local and remote) are set to zero.

8. DEMAND SIDE MANAGEMENT (DSM) AND GENERATION SIDE MANAGEMENT (GSM)

- 8.1 Some EDCM Customers are subject to demand side management (DSM) or generation side management (GSM) agreements.
- 8.2 For Connectees with DSM agreements, let “chargeable capacity” be equal to the Maximum Import Capacity minus the capacity that is subject to restrictions under a DSM agreement. These restrictions would take into account any seasonal variations built into these agreements.
- 8.3 For Connectees with DSM agreements, DSM-adjusted local and remote (or parent and grandparent) elements of the LRIC charge are calculated as the product of the ratio of “chargeable capacity” to Maximum Import Capacity and the unadjusted elements of the LRIC charge. Where the Maximum Import Capacity is zero, this ratio is set to 1. The DSM-adjusted local element of the LRIC charge 1 is applied to the Maximum Import Capacity, and the DSM-adjusted remote (or parent and grandparent) element of the LRIC charge 1 is applied to units consumed during the super-red time band.
- 8.4 For Connectees with GSM agreements, no adjustments are made in the EDCM.

9. TRANSMISSION CONNECTION (EXIT) CHARGES FOR DEMAND

- 9.1 A separate transmission exit charge is applied to demand tariffs.
- 9.2 A single charging rate, in p/kW/day is calculated as follows:

Transmission exit charging rate p/kW/day = $100 / DC * ISOP \text{ charge} / (\text{CDCM system maximum load} + \text{total EDCM peak time consumption})$

Where:

DC is the number of days in the Charging Year.

ISOP charge is the DNO Party’s forecast annual expenditure on transmission connection point charges in £.

CDCM system maximum load is the forecast system simultaneous maximum load from CDCM Connectees (in kW) from CDCM table 2506.

Total EDCM peak time consumption (in kW) calculated by multiplying the Maximum Import Capacity of each Connectee by the forecast peak-time kW divided by forecast maximum kVA of that Connectee (adjusted for losses to transmission and, if necessary, for Connectees connected for part of the Charging Year) and aggregating across all EDCM Customer demand.

The single p/kW/day charging rate is converted into a p/kVA/day import capacity based charge for each EDCM Connectees as follows:

Transmission exit charge p/kVA/day = [Transmission exit charging rate in p/kW/day]
 * [Forecast peak-time kW divided by kVA of that Connectee, adjusted for transmission losses and, if necessary for Connectees connected part of the year]

10. TRANSMISSION CONNECTION (EXIT) CREDITS FOR GENERATORS

- 10.1 A capacity-based credit related to transmission exit is applied to generation tariffs.
- 10.2 Transmission exit credits are paid to generators that have an agreement with the DNO, the terms of which require the generator, for the purposes of P2/6 compliance, to export power during supergrid transformer (SGT) outage conditions.
- 10.3 The rate in p/kVA/day for each generation customer would be calculated as follows:

Transmission exit credit p/kVA/day = -[Transmission exit charging rate in p/kW/day]
 * [Capacity eligible for credits in kW] / [Chargeable Export Capacity in kVA of that Connectee]

Where:

Transmission exit charging rate in p/kW/day is calculated as described for demand tariffs.

Capacity eligible for credits (in kW) is the capacity that is made available by the generator under the agreement with the DNO.

Chargeable Export Capacity (in kVA) is the forecast average value of the maximum export capacity of the generator over the charging year, less any capacity that is exempt from use of system charges in the charging year.

- 10.4 The generation transmission connection (exit) rate is not calculated for Connectees with zero Chargeable Export Capacity.
- 10.5 Transmission connection (exit) credits are applied to the Chargeable Export Capacity (in kVA)

11. REACTIVE POWER CHARGES

- 11.1 The EDCM does not include a separate charge component for any reactive power flows.

12. EXPORT CAPACITY CHARGES

- 12.1 The EDCM includes an export capacity charge.
- 12.2 First, an EDCM generation revenue target would be calculated as follows:
- 12.3 EDCM DG revenue target £/year = $GL * [Total\ 2005-2010\ EDCM\ generation\ capacity] / ([Total\ 2005-2010\ EDCM\ generation\ capacity] + [Total\ 2005-2010\ CDCM\ generation\ capacity]) + AGPa * [Total\ post-2010\ EDCM\ generation\ capacity] / ([Total\ post-2010\ EDCM\ generation\ capacity] + [Total\ post-2010\ CDCM\ generation\ capacity]) + (OM * ([Total\ Pre-2005\ EDCM\ DG\ capacity] + [Total\ Post-2010\ EDCM\ DG\ capacity]))$

Where:

GL is the incentive revenue in the charging year in respect of generation connected between 2005 and 2010 calculated for the charging year as in paragraph 11.10 of the Special Conditions of the Electricity Distribution Licence (CRC11). From and including Regulatory Year 2015/2016 GL is zero.

AGPa is the average of the values of GPa for the charging year and each of the two years immediately preceding the charging year. For Regulatory Year 2014/2015 GPa is calculated using a modified version of the formula in paragraph 11.6 of the Electricity

Distribution Licence (CRC11) resulting from DPCR5. To calculate GPa, the term GPX is replaced by the term GPS in the formula in paragraph 11.6. Both GPX and GPS are defined in paragraph 11.7 of the same document. For Regulatory Years 2015/16 onwards GPa is zero.

Total Pre-2005 EDCM DG capacity is the aggregate maximum export capacity of all non-exempt EDCM generators that connected before 1 April 2005, adjusted for part-year connected generators. In the case of generators that have subsequently increased their maximum export capacity, the part of their capacity that was added after 1 April 2005 would be ignored.

Total 2005–2010 EDCM generation capacity is the sum of the maximum export capacities of all non-exempt EDCM generators that connected between 1 April 2005 and 31 March 2010, adjusted for part-year connected generators.

Total Post–2010 EDCM generation capacity is the sum of the maximum export capacities of all non-exempt EDCM generators that connected on or after 1 April 2010, adjusted for part-year connected generators. In the case of generators that originally connected before 1 April 2010 and have increased their maximum export capacity on or after 1 April 2010, the capacity that was added after 1 April 2010 should be included.

Total 2005–2010 CDCM generation capacity is the sum of the maximum export capacities of all non-exempt CDCM generators that connected between 1 April 2005 and 31 March 2010, adjusted for part-year connected generators.

Total Post–2010 CDCM generation capacity is the sum of the maximum export capacities of all non-exempt CDCM generators that connected on or after 1 April 2010, adjusted for part-year connected generators.

12.4 OM is an allowance in £/kW in respect of the operational and maintenance costs for assets that are deemed to have been installed for the purposes of connecting generators to the distribution network. The value of OM is set to £0.20/kW.

12.5 A fixed export capacity charge in p/kVA/day is calculated as follows:

$$\text{Fixed export capacity charge in p/kVA/day} = (100 / \text{DC}) * [\text{EDCM DG revenue target}] / [\text{Total EDCM generation capacity}]$$

Where:

EDCM DG revenue target in £/year is calculated as described above

Total EDCM generation capacity (in kVA) is the aggregate Chargeable Export Capacity of all Connectees, adjusted, if necessary for Connectees connected part of the year.

- 12.6 The fixed export capacity charge in p/kVA/day is applied to the Chargeable Export Capacity of each EDCM Connectee.

13. ALLOCATION DRIVERS FOR OTHER CHARGE ELEMENTS IN THE EDCM

- 13.1 In addition to charges calculated using the FCP and LRIC methodologies and transmission connection (exit) charges, the EDCM includes charge elements relating to:

- the DNO Party's direct operating costs (this includes inspection and maintenance costs, operating expenditure relating to fault repairs and the cost of tree cutting);
- the DNO Party's indirect costs. (these are costs that are not directly related to network assets, such as business support costs);
- the DNO Party's network rates (these are business rates paid by DNO Parties); and
- the DNO Party's residual revenue.

- 13.2 The residual revenue is that part of the DNO Party's Allowed Revenue less any revenue relating to recovery of the DNO Party's Supplier of Last Resort and Eligible Bad Debt pass-through costs that has not been pre-allocated to demand charges using cost-based charge elements.

- 13.3 EDCM charge elements are determined using allocation drivers. The following allocation drivers are used in the EDCM:

- The value of assets that are for the sole use of a Connectee (sole use assets). This is relevant to import and export charges.
- The value of site-specific shared network assets used by the Connectee. This is relevant to import charges only. The sum of historical consumption at the time of system peak and 50 per cent of Maximum Import Capacity. This is relevant to import charges only.
- Chargeable Export Capacity. This is relevant to export charges only.

13.4 The methods used to determine the value of sole use assets and shared site-specific shared network assets are described below.

14. SOLE USE ASSETS

- 14.1 The value of a customer's sole use assets used is expressed in the form of a modern equivalent asset value (MEAV) in £.
- 14.2 Sole use assets are assets in which only the consumption or output associated with a single Connectee can directly alter the power flow in the asset, taking into consideration all possible credible running arrangements, i.e. all assets between the Connectee's Entry/Exit Point(s) and the Point(s) of Common Coupling with the general network are considered as sole use assets.
- 14.3 The Point of Common Coupling for a particular single Connectee is the point on the network where the power flow associated with the single Connectee under consideration, may under some (or all) possible arrangements interact with the power flows associated with other Connectees, taking into account all possible credible running arrangements.
- 14.4 Where a single site has both import and export charges, associated with import and export meter registrations, the sole use assets are allocated between the import and export proportionally to Maximum Import Capacity and Maximum Export Capacity respectively. Where any part of the Maximum Export Capacity associated with an export meter registration is exempt from use of system charges in the charging year, the

value of sole use assets allocated to the export tariff is reduced by multiplying it by the ratio of the Chargeable Export Capacity to the Maximum Export Capacity.

- 14.5 Where an EDCM site was originally connected as a single Connected Installation, and has subsequently split into multiple Connected Installations, these sites continue to be considered as one site for the purposes of determining sole use assets. The sole use asset MEAV is allocated between these Connected Installations in proportion to their Maximum Import Capacities and Maximum Export Capacities.

15. SITE-SPECIFIC SHARED NETWORK ASSETS

- 15.1 A Connectee's notional site-specific shared network asset value is the value of network assets that are deemed to be used by that Connectee, other than sole use assets as defined earlier.
- 15.2 The value of notional site-specific shared assets used by each Connectee is expressed in the form of a modern equivalent asset value (MEAV) in £.
- 15.3 The value of shared network assets used by each demand Connectee is calculated as set out below.
- 15.4 Five levels are defined for the network's assets:
- Level 1 comprises 132 kV circuits.
 - Level 2 comprises substations with a primary voltage of 132 kV and a secondary voltage of 22 kV or more.
 - Level 3 comprises circuits of 22 kV or more but less than 132 kV.
 - Level 4 comprises substations with a primary voltage of 22 kV or more but less than 132 kV and a secondary voltage of less than 22 kV.
 - Level 5 comprises substations with a primary voltage of 132 kV and a secondary voltage of less than 22 kV.
- 15.5 In some cases, it might be appropriate to treat 66 kV equipment as being equivalent to 132 kV equipment and allocate Connectees to categories accordingly.

- 15.6 EDCM Customers are split into 15 categories based on the parts of the EHV network they are deemed to use. This is based on the Point of Common Coupling. The Point of Common Coupling might be at a different voltage than the Connectee's connection, and might also be at a different voltage than the voltage of connection when the Connectee was connected.

Table 15.6 Categorisation of EDCM Customers

Category	Definition
Category 0000	Point of Common Coupling at the GSP, whether the GSP is shared or not.
Category 1000	In England or Wales only, Point of Common Coupling at a voltage of 132 kV, unless the Connectee qualifies for category 0000.
Category 1100	Point of Common Coupling at 22 kV or more on the secondary side of a substation where the primary side is attached to a 132 kV circuit.
Category 0100	Point of Common Coupling at 22 kV or more, but less than 132 kV, on the secondary side of a substation where the primary side is attached at 132 kV to a co-located GSP with no use of any 132 kV circuits.
Category 1110	Point of Common Coupling at a voltage of 22 kV or more, but less than 132 kV, not at a substation, fed from a substation whose primary side is attached to a 132 kV distribution circuit.
Category 0110	Point of Common Coupling at a voltage of 22 kV or more, but less than 132 kV, not at a substation, fed from a substation whose primary side is attached at 132 kV to a co-located GSP with no use of any 132 kV circuits.
Category 0010	Point of Common Coupling at a voltage of 22 kV or more, but less than 132 kV, fed from a GSP with no intermediate transformation.
Category 0001	Point of Common Coupling at a voltage of less than 22 kV on the secondary side of a substation where the primary side is attached at 132 kV to a co-located GSP with no circuit.
Category 0002	Point of Common Coupling at a voltage of less than 22 kV on the secondary side of a substation where the primary side is attached at 22 kV or more but less than 132 kV, to a co-located GSP with no circuit.

Category 1001	Point of Common Coupling at a voltage of less than 22 kV on the secondary side of a substation whose primary side is attached to a 132 kV distribution circuit.
Category 0011	Point of Common Coupling at a voltage of less than 22 kV on the secondary side of a substation whose primary side is at a voltage of 22 kV or more, but less than 132 kV, fed from a GSP with no intermediate transformation.
Category 0111	Point of Common Coupling at a voltage of less than 22 kV on the secondary side of a substation whose primary side is at a voltage of 22 kV or more, but less than 132 kV, fed through a distribution circuit from a substation whose primary side is attached at 132 kV to a co-located GSP with no circuit.
Category 0101	Point of Common Coupling at a voltage of less than 22 kV on the secondary side of a substation whose primary side is at a voltage of 22 kV or more, but less than 132 kV, fed from the secondary side of a co-located substation whose primary side is attached at 132 kV to a co-located GSP with no circuit.
Category 1101	Point of Common Coupling at a voltage of less than 22 kV on the secondary side of a substation whose primary side is at a voltage of 22 kV or more, but less than 132 kV, fed from the secondary side of a co-located substation whose primary side is attached to a 132 kV distribution circuit.
Category 1111	Point of Common Coupling at a voltage of less than 22 kV on the secondary side of a substation whose primary side is at a voltage of 22 kV or more, but less than 132 kV, fed through a distribution circuit from a substation whose primary side is attached to a 132 kV distribution circuit.

15.7 All references to GSP in table 15.6 above relate to interconnections with the onshore National Electricity Transmission System.

15.8 The figure below provides examples of Connectees who might be placed in each of the categories described above.

Customer Categories

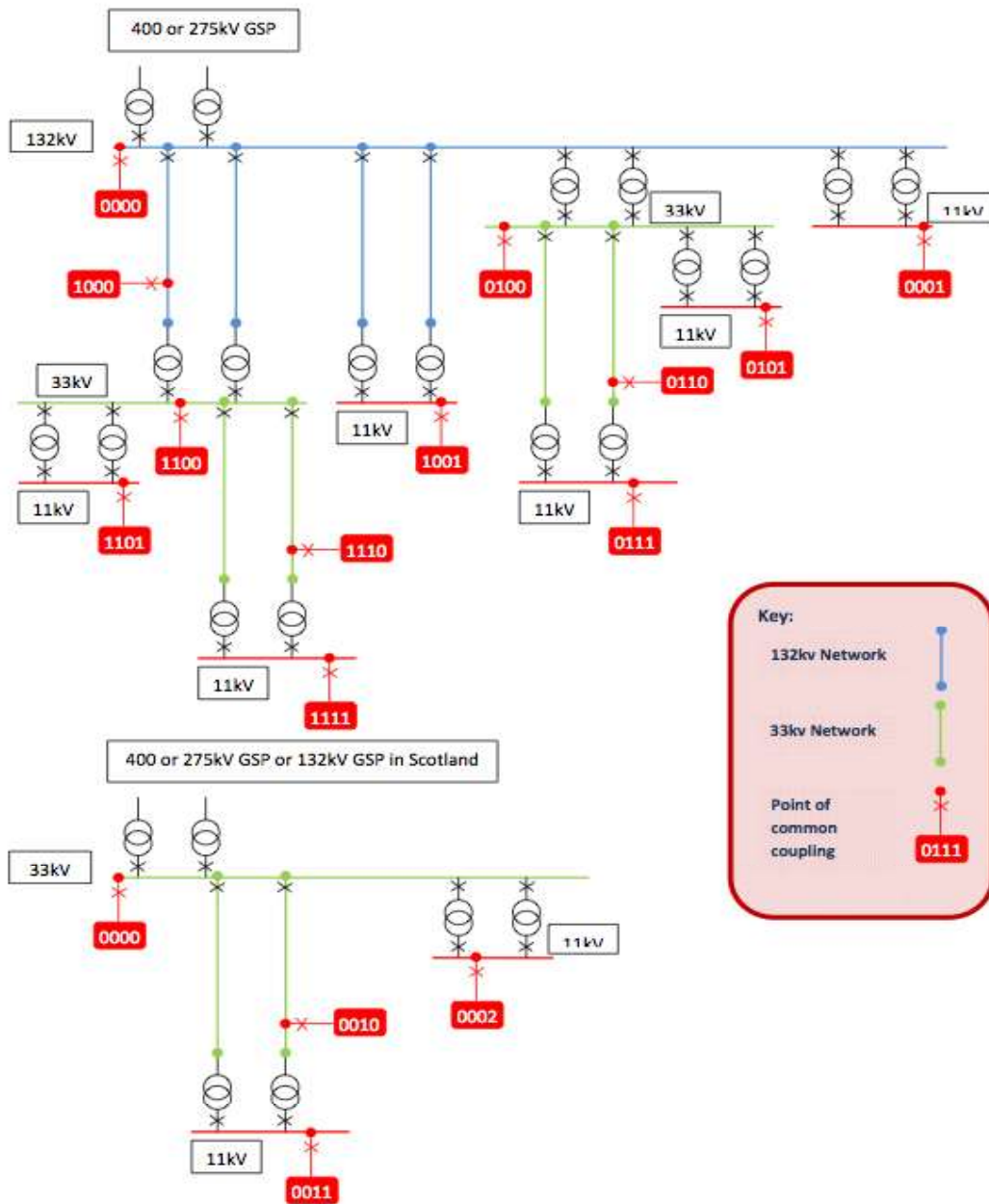

15.9 The use of each network level by each EDCM Connectee is determined according to the rules set out in table 15.9.

Table 15.9 Use of each network level by each EDCM Connectee

EDCM Customers in category	Level 1	Level 2	Level 3	Level 4	Level 5
Category 0000	Zero	Zero	Zero	Zero	Zero
Category 1000	Capacity kVA	Zero	Zero	Zero	Zero
Category 1100	Peak-time active kW	Capacity kVA	Zero	Zero	Zero
Category 0100	Zero	Capacity kVA	Zero	Zero	Zero
Category 1110	Peak-time active kW	Peak-time active kW	Capacity kVA	Zero	Zero
Category 0110	Zero	Peak-time active kW	Capacity kVA	Zero	Zero
Category 0010	Zero	Zero	Capacity kVA	Zero	Zero
Category 0001	Zero	Zero	Zero	Zero	Capacity kVA
Category 0002	Zero	Zero	Zero	Capacity kVA	Zero
Category 1001	Peak-time active kW	Zero	Zero	Zero	Capacity kVA
Category 0011	Zero	Zero	Peak-time active kW	Capacity kVA	Zero
Category 0111	Zero	Peak-time active kW	Peak-time active kW	Capacity kVA	Zero
Category 0101	Zero	Peak-time active kW	Zero	Capacity kVA	Zero
Category 1101	Peak-time active kW	Peak-time active kW	Zero	Capacity kVA	Zero
Category 1111	Peak-time active kW	Peak-time active kW	Peak-time active kW	Capacity kVA	Zero

15.10 Category 0000 Connectees are deemed not to use any network assets other than sole use assets.

15.11 An average network asset value per kVA (in £/kVA) is calculated in respect of each network level. The average network asset value for the network level of connection is based on the Maximum Import Capacity of the Connectee, and for network levels above on consumption at peak time.

Average network asset value for capacity at level L (£/kVA) = $NARL * AE / (1 + DL)$

Average network asset value for demand at level L (£/kVA) = $NARL * D * LAF$

Where:

NAR L is the network asset rate at level L in £/kW based on the 500 MW model.

DL is the Diversity Allowance from the level exit to the GSP group (from CDCM table 2611).

D is the peak time active power consumption in (kW/kVA). This is calculated as the historical peak-time kW divided by historical maximum kVA.

LAF is the loss adjustment factor to transmission from the CDCM for the network level relevant to the EDCM Customer category of that Connectee. See table 15.11 below for the correspondence between EDCM Customer categories and network levels.

AE is the active power equivalent of capacity adjusted to transmission (in kW/kVA). This is calculated by multiplying the power factor in the 500 MW model (0.95) by the loss adjustment factor to transmission for the network level relevant to that Connectee (as above).

Table 15.11 Customer category relevant network level for loss adjustment factors

Customer categories	Relevant network level for loss adjustment factors
0000	GSP (the loss adjustment factor is always 1 for this network level)
1000	132kV (level 1)
1100 and 0100	132kV/EHV (level 2)
1110, 0110 and 0010	EHV (level 3)
1111, 1101, 0101, 0111, 0011 and 0002	EHV/HV (level 4)
1001 and 0001	132kV/HV (level 5)

15.12 Again, separate site-specific asset values per kVA (in £/kVA) are calculated in respect of each network level. The asset value for the network level of connection is based on the Maximum Import Capacity of the Connectee, and for network levels above on consumption at peak time.

Site-specific asset value for capacity at level L (£/kVA) = NUL * Average network asset value for capacity at level L (£/kVA)

Notional asset value for demand at level L (£/kVA) = NUL * Average network asset value for demand at level L (£/kVA)

Where:

NUL is the network use factor for that Connectee at level L, representing the proportion of the average 500 MW model assets that the Connectee is deemed to use at that level. The methodology to calculate these network use factors is set out in Annex 2 of this Schedule.

Average notional asset value for capacity at level L is the voltage level average calculated as described earlier.

Average notional asset value for demand at level L is the voltage level average calculated as described earlier.

- 15.13 Network use factors for import charges of a mixed import-export site that is generation-dominated are set to default values. These default values are equal to the “collars” for each network level calculated as described in section on demand scaling. Generation-dominated sites are determined according to the rules set out in the LRIC methodology to determine whether a location is to be modelled as a generation site.
- 15.14 The total value of the site-specific shared assets required to serve each Connectee is calculated according to the formula:

$$\text{TNA} = \text{NAC} + (\text{NAD} * (1 - (\text{Hours in super-red for which not a customer} / \text{Annual hours in super-red})) * (\text{Days in year} / (\text{Days in year} - \text{Days for which not a customer})))$$

Where:

TNA is the total site-specific network assets in £/kVA required to serve a Connectee.

NAC is the site-specific asset value in £/kVA for capacity for that Connectee aggregated across all levels.

NAD is the site-specific asset value in £/kVA for demand for that Connectee aggregated across all levels.

- 15.15 Total site-specific shared assets is the aggregate value (in £) of all site-specific shared assets for EDCM Connectees. This is calculated by multiplying TNA by the Maximum Import Capacity (adjusted, if necessary, for Connectees connected for part of the Charging Year), and then aggregating across all EDCM Connectees.

16. CALCULATION OF THE EDCM DEMAND REVENUE TARGET

- 16.1 The EDCM demand revenue target is the share of the DNO Party’s Allowed Revenue less any revenue relating to recovery of the DNO Party's Supplier of Last Resort and Eligible Bad Debt pass-through costs (excluding transmission exit charges and net revenue from EDCM generation) that will be recovered from EDCM Connectees through import charges.
- 16.2 This section describes the method used to calculate the EDCM demand revenue target.

- 16.3 A single contribution rate for network rates is calculated for all EDCM Connectees as follows:

Network rates contribution rate (per cent) = $NR / (\text{Total site-specific shared assets} + \text{Total EDCM sole use assets} + \text{EHV assets} + \text{HV and LV network assets} + \text{HV and LV service model assets})$

Where:

NR is the DNO Party's total expenditure on network rates.

Total site-specific shared assets is the aggregate value (in £) of all site-specific shared assets for EDCM (Load) Connectees.

Total EDCM sole use assets is the aggregate sole use asset MEAVs of all EDCM Connectees, excluding the value of sole use assets associated with exempt export capacity, adjusted for part-year connected Connectees. EHV assets are the aggregate EHV assets in the CDCM model.

HV and LV network assets from the CDCM model.

HV and LV service model assets from the CDCM model.

- 16.4 A single contribution rate for direct operating costs is calculated for all EDCM Connectees as follows:

Direct operating costs contribution rate (per cent) = $DOC / (\text{Total site-specific shared assets} + \text{Total EDCM sole use assets} + \text{EHV assets} + (\text{HV and LV network assets} + \text{HV and LV service model assets}) / 0.68)$

Where:

DOC is the DNO Party's total expenditure on direct operating costs.

Total site-specific shared assets is the aggregate value (in £) of all site-specific shared assets for EDCM Connectees.

Total EDCM sole use assets is the aggregate sole use asset MEAVs of all EDCM Connectees, excluding the value of sole use assets associated with exempt export

capacity, adjusted for part-year connected Connectees. EHV assets are the aggregate EHV assets in the CDCM model.

HV and LV network assets from the CDCM model.

HV and LV service model assets from the CDCM model.

0.68 is the operating intensity factor.

- 16.5 A single contribution rate for indirect costs is calculated for all EDCM Connectees as follows:

$$\text{Indirect costs contribution rate (per cent)} = \frac{\text{INDOC}}{(\text{Total site-specific shared assets} + \text{Total EDCM sole use assets} + \text{EHV assets} + (\text{HV and LV network assets} + \text{HV and LV service model assets}) / 0.68)}$$

Where:

INDOC is the DNO Party's total expenditure on indirect costs.

Total site-specific shared assets is the aggregate value (in £) of all site-specific shared assets for EDCM Connectees.

Total EDCM sole use assets is the aggregate sole use asset MEAVs of all EDCM Connectees, excluding the value of sole use assets associated with exempt export capacity, adjusted for part-year connected Connectee. EHV assets are the aggregate EHV assets in the CDCM model.

HV and LV network assets from the CDCM model.

HV and LV service model assets from the CDCM model.

0.68 is the operating intensity factor.

- 16.6 Next, a residual revenue contribution rate is calculated as follows:

$$\text{Residual revenue contribution rate (per cent)} = \frac{(\text{AR} - \text{DOC} - \text{INDOC} - \text{NR} - \text{GCN})}{(\text{Total site-specific shared assets} + \text{EHV assets} + \text{HV and LV network assets})}$$

Where:

AR is the DNO Party's total Allowed Revenue excluding transmission exit charges in £/year and excluding any revenue relating to recovery of the DNO Party's Supplier of Last Resort and Eligible Bad Debt pass-through costs.

DOC is the DNO Party's total expenditure on direct operating costs.

INDOC is the DNO Party's total expenditure on indirect costs.

NR is the DNO Party's total expenditure on network rates.

GCN is the total forecast net revenue in £/year from the application of EDCM export charges, including the EDCM generation fixed charge. This amount is estimated by applying the calculated EDCM export charges rounded to the relevant number of decimal points.

Total site-specific shared assets is the aggregate value (in £) of all site-specific shared assets for EDCM Connectees.

EHV assets are the aggregate EHV assets in the CDCM model.

HV and LV network assets from the CDCM model.

- 16.7 The contribution rates for network rates, direct costs, indirect costs and residual revenue is converted into a £/year import capacity based contribution and a demand sole use asset MEAV based contribution for each EDCM Connectee.

Import capacity based network rates contribution for each Connectee = $TNA * NR$
rate * import capacity

Import capacity based direct operating costs contribution for each Connectee = $TNA * DOC$
rate * import capacity

Import capacity based indirect costs contribution for each Connectee = $TNA * INDOC$
rate * import capacity

Import capacity based residual revenue contribution for each Connectee = $TNA * residual$
revenue rate * import capacity

Where:

TNA is the total site-specific assets (£/kVA) for that EDCM Connectee.

NR rate is the network rates contribution rate in per cent.

DOC rate is the direct operating costs contribution rate in per cent.

INDOC rate is the indirect costs contribution rate in per cent.

Residual revenue rate is the residual revenue contribution rate in per cent.

Import capacity is the Maximum Import Capacity (adjusted, if necessary, if the Connectee is connected for part of the Charging Year) in kVA for that EDCM Connectee.

16.8 The demand sole use asset MEAV based contribution in £/year is calculated as follows:

Demand sole use asset based network rates contribution = $S * NR \text{ rate}$

Demand sole use asset based direct operating costs contribution = $S * DOC \text{ rate}$

Demand sole use asset based indirect costs contribution = $S * INDOC \text{ rate}$

Where

S is the MEAV of demand sole use assets of that EDCM Connectee (adjusted for Connectees connected for part of the Charging Year).

NR rate is the network rates contribution rate in per cent.

DOC rate is the direct operating costs contribution rate in per cent.

INDOC rate is the indirect costs contribution rate in per cent.

16.9 The target contributions from import capacity and sole use assets are aggregated across all EDCM Connectees.

16.10 The aggregate EDCM demand revenue target is calculated as the sum, across all EDCM demand, of the contributions based on import capacities and demand sole use assets, less the total reduction in fixed charges made to EDCM customers under paragraph 17.2. Such fixed charge reduction is to be derived as follows:

$$\text{FCR} = \text{OMR} * (\text{EHV assets} + \text{HV and LV network assets}) / (\text{Total site-specific shared assets} + \text{EHV assets} + \text{HV and LV network assets})$$

Where

OMR is the total reduction in fixed charges made to EDCM customers under paragraph 17.2, where the reduction is derived as the aggregated value of the amount each EDCM customer would have paid under paragraph 17.1 less the amount paid under 17.2 for eligible customers.

17. FIXED CHARGES FOR IMPORT AND EXPORT

- 17.1 The contribution rates for network rates and direct operating costs are converted into a p/day fixed charge for the sole use assets of each EDCM Connectee as follows:

Import fixed charge on sole use assets in p/day = $100 / \text{DC} * \text{SD} * (\text{NR contribution rate} + \text{DOC contribution rate})$

Export fixed charge on sole use assets in p/day = $100 / \text{DC} * \text{SG} * (\text{NR contribution rate} + \text{DOC contribution rate})$

Where

DC is the number of days in the Charging Year.

SD is the MEAV of sole use assets allocated to demand of that EDCM Connectee.

SG is the MEAV of sole use assets allocated to generation of that EDCM Connectee excluding the value of sole use assets associated with exempt export capacity.

NR contribution rate is the network rates contribution rate in per cent.

DOC contribution rate is the direct operating costs contribution rate in per cent.

- 17.2 Where a customer demonstrates with written evidence to the DNO Party (or where the DNO Party has written evidence) that the customer (or its predecessors) made a capitalised O&M payment in respect of a connection to the DNO Party's network, and the period over which the O&M payment was capitalised remains unexpired, then the

import fixed charge will be calculated as set out below (and the calculation for the import fixed charge in paragraph 17.1 will not apply).

The sole use assets will be split between those where capitalised O&M has been paid and those where it has not, and the fixed charge will be derived as follows:

$$p/\text{day} = (((\text{DOC rate} + \text{NR rate}) * \text{SUA MEAVU}) + (\text{NR rate} * \text{SUA MEAVP})) / (\text{days in Charging Year}) * 100$$

Where:

DOC rate is the direct operating costs contribution rate in per cent;

NR rate is the network rates contribution rate in per cent;

Where SUA MEAVU is the Modern Equivalent Asset Value of Sole Use Assets where capitalised O&M has not been paid (or the period over which it was to be capitalised has expired);

and SUA MEAVP is the Modern Equivalent Asset Value of Sole Use Assets where capitalised O&M has been paid (and the period over which it was to be capitalised has not expired).

- 17.3 For customers that are classified as exempt pre-2005 EDCM Distributed Generators (DGs), it is deemed for the purposes of paragraph 17.2 that the customer paid capitalised O&M to be capitalised over a period of 25 years from connection.

18. DEMAND SCALING

- 18.1 Demand scaling is the process by which import charges to EDCM Connectees are set so that the forecast notional recovery from the application of those import charges to EDCM Connectees matches the EDCM demand revenue target.
- 18.2 Demand scaling using the site-specific assets approach involves the following steps:
- Calculating adjusted site-specific shared asset values for each Connectee using network use factors that have been subjected to a cap and collar.

- Allocation of the direct operating cost and network rates elements in the EDCM demand revenue target to individual EDCM Connectees on the basis of adjusted site-specific assets and sole use assets. [a]
- Allocation of the indirect cost element in the EDCM demand revenue target to individual EDCM Connectees on the basis of their consumption at the time of the DNO Party's peak and 50 per cent of Maximum Import Capacity as a p/kVA/day charge. [b]
- Forecasting the notional recoveries from the application of LRIC charges to EDCM Connectee. [c]
- Application of residual charges is provided in accordance with paragraph 18.18 below.

18.3 Adjusted site-specific assets are calculated using network use factor that have been subjected to caps and collars.

18.4 A cap and a collar are calculated for each network level as follows:

- In ascending order, list the network use factors for all EDCM Connectees in all DNO Party areas relating to that network level, excluding all the factors that are either equal to zero or 1, or not used, based on the customer categories of each EDCM Connectee.
- Divide the list into two segments, one that contains factors that are lower than 1, and the other than contains the factors that are higher than 1.
- Take the list segment containing factors that are lower than 1. Starting from the lowest factor in this list segment, calculate the factor at the 15th percentile. This is the collar.
- Take the list segment containing factors higher than 1. Starting from the lowest factor in this segment, calculate the factor at the 85th percentile. This is the cap.

- 18.5 The same cap and collar would apply in all DNO Party areas to network use factors at that network level.
- 18.6 The caps and collars are recalculated triennially, with the three year cycle having been established when caps and collars were calculated when determining 2017/18 charges (in 2015). In years where a recalculation has not been carried out, the values used remain at the most recently calculated values.
- 18.7 Where year t is a charging year for which the caps and collars are being recalculated, the caps and collars calculated and used for years t, t+1 and t+2 will be based on applying the calculation detailed in paragraph 18.4 to the average of network use factors which were used in the calculation of charges applicable to years t-3, t-2 and t-1.
- 18.8 The network use factor caps and collars that are updated in accordance with paragraphs 18.6 and 18.7 will be maintained by the DNO Parties and referenced within the EDCM user manual.
- 18.9 Separate adjusted site-specific asset values per kVA (in £/kVA) is calculated in respect of each network level. The asset value for the network level of connection is based on the Maximum Import Capacity of the EDCM Connectee, and for network levels above on consumption at peak time.

Adjusted site-specific asset value for capacity at level L (£/kVA) = nU_{aL} * Average network asset value for capacity at level L (£/kVA)

Adjusted site-specific asset value for demand at level L (£/kVA) = nU_{aL} * Average network asset value for demand at level L (£/kVA)

Where:

nU_{aL} is the adjusted network use factor for that EDCM Connectee at level L after application of the cap and collar.

Average notional asset value for capacity at level L is the voltage level average calculated as described earlier.

Average notional asset value for demand at level L is the voltage level average calculated as described earlier.

- 18.10 The total value of the adjusted site-specific shared assets required to serve each EDCM Connectee is calculated according to the formula:

$$TNAa = NACa + (NADa * (1 - (\text{Hours in super-red for which not a customer} / \text{Annual hours in super-red})) * (\text{Days in year} / (\text{Days in year} - \text{Days for which not a customer})))$$

Where:

TNAa is the total adjusted site-specific network assets in £/kVA required to serve a EDCM Connectee.

NACa is the adjusted site-specific asset value in £/kVA for capacity for that EDCM Connectee aggregated across all levels.

NADa is the adjusted site-specific asset value in £/kVA for demand for that EDCM Connectee aggregated across all levels.

- 18.11 Total adjusted site-specific shared assets for all EDCM demand is the aggregate value (in £) of all adjusted site-specific shared assets for EDCM Connectees. This is calculated by multiplying TNAa by the Maximum Import Capacity (adjusted, if necessary, for Connectees connected for part of the Charging Year), and then aggregating across all EDCM demand.
- 18.12 The direct cost and network rates allocations to individual demand Connectees is determined in the same way as the contributions to the EDCM demand revenue target was calculated, except that adjusted site-specific assets are used.
- 18.13 A single asset based charging rate for network rates is calculated for all EDCM Connectee. This is calculated as follows:

$$\text{Network rates charging rate (per cent)} = \text{EDCM NR contribution} / (\text{Total adjusted site-specific shared assets})$$

Where:

EDCM NR contribution is the sum of the import capacity based network rates contribution from each EDCM Connectee.

Total adjusted site-specific shared assets is the aggregate value (in £) of all adjusted site-specific shared assets for EDCM Connectees.

- 18.14 A single asset based charging rate for direct operating costs is calculated for all EDCM Connectees. This is calculated as follows:

Direct operating costs charging rate (per cent) = EDCM DOC contribution / (Total adjusted site-specific shared assets)

Where:

EDCM DOC contribution is the sum of the import capacity based direct costs contribution from each EDCM Connectee.

Total adjusted site-specific shared assets is the aggregate value (in £) of all adjusted site-specific shared assets for EDCM Connectees.

- 18.15 The charging rates for network rates and direct operating costs are converted into p/kVA/day import capacity based charges for each EDCM Connectee.

Network rates and direct costs charge in p/kVA/day = $(100 / DC) * TNAa * (NR \text{ rate} + DOC \text{ rate})$

Where:

DC is the number of days in the Charging Year.

TNAa is the total adjusted site-specific assets (£/kVA) for that EDCM Connectee.

NR rate is the network rates charge rate in per cent.

DOC rate is the direct operating costs charge rate in per cent.

- 18.16 A p/kVA/day charging rate for indirect costs for each EDCM Connectee is calculated on the basis of historical demand at the time of the DNO Party's peak and 50 per cent of Maximum Import Capacity of that Connectee.

Indirect cost charging rate in p/kVA/day = $100 / DC * (\text{Aggregate indirect cost contribution}) / \text{Volume for scaling}$

Where:

DC is the number of days in the Charging Year.

Volume for scaling is calculated as the sum of $(0.5 + \text{coincidence factor}) \times \text{import capacity} \times \text{LDNO factor}$ across all EDCM Connectees.

Coincidence factor is calculated as the forecast peak-time consumption in kW divided by Maximum Import Capacity in kVA of that Connectee (based on historical data) multiplied by $(1 - (\text{Hours in super-red for which not a customer} / \text{Annual hours in super-red})) \times (\text{Days in year} / (\text{Days in year} - \text{Days for which not a customer}))$

Import capacity is the Maximum Import Capacity (adjusted if the Connectee is connected for part of the Charging Year) in kVA for that EDCM Connectee.

LDNO factor takes the value 0.5 if the EDCM Connectee is connected to a LDNO's network and 1 otherwise.

Aggregate indirect cost contribution is the sum of the import capacity based and sole use asset based indirect cost contribution from each EDCM Connectee.

- 18.17 The p/kVA/day charging rate for indirect costs is converted into an import capacity based charge for each EDCM Connectee as follows:

Import capacity based INDOC charge in p/kVA/day = Indirect cost charging rate * $(0.5 + \text{coincidence factor}) \times \text{LDNO factor}$

Where:

Indirect cost charging rate is the Distribution System-wide p/kVA/day rate calculated as described in the previous paragraph.

Coincidence factor is calculated as the forecast peak-time consumption in kW divided by Maximum Import Capacity in kVA of that Connectee (based on historical data) multiplied by $(1 - (\text{Hours in super-red for which not a customer} / \text{Annual hours in super-red})) \times (\text{Days in year} / (\text{Days in year} - \text{Days for which not a customer}))$

LDNO factor takes the value 0.5 if the EDCM Connectee is connected to a LDNO's network and 1 otherwise.

18.18 Residual charges will be allocated as follows:

- The difference between the EDCM demand revenue target and the sum of a, b and c under Paragraph 18.2 above will be apportioned to specific charging bands as set out in paragraph 2.4 of Schedule 32, according to the total forecast metered import consumption for the charging band proportionate to the total forecast metered import consumption for all Final Demand Sites which are EHV Designated Properties.
- The allocated proportion of the residual value to each charging band will then be divided equally among all Final Demand Sites within that charging band, resulting in the same level of residual fixed charge for each such site.
- Residual charges for each Final Demand Site will be applied as a fixed charge adder (p/Final Demand Site/day) calculated as follows: the revenue surplus or shortfall (in pence) to be returned or recovered for the band that the Final Demand Site is in; divided by the total number of Final Demand Sites in that band; divided by days in the charging year.
- For any DNO Party, if the count of Final Demand Sites in any given charging band is less than two in the charging year for which tariffs are being determined, the residual fixed charge for that band will be calculated as set out in accordance with the bullet points above, but the total forecast metered import consumption and total count of Final Demand Sites in that band will be combined with the equivalent information for the band above that band. If the band in question is the highest band, then it will be combined with the equivalent information for the band below that band. The residual fixed charge should therefore be the same for all Final Demand Sites in the combined bands. There must be no single or combined band with less than two Final Demand Sites within that band. A Final Demand Site connected during the year will be counted as a fraction based on the proportion of the year for which the site was connected.
- There are eight possible combinations for grouping non-domestic charging bands under the above bullet point. Where there are less than two Final Demand Sites in

a band the grouping of the bands under the above bullet point will be in accordance with the preference order given in the table below.

Preference order for band grouping combinations	Band 1	Band 2	Band 3	Band 4
First	1	2	3	4
Second	1 + 2		3	4
Third	1	2 + 3		4
Fourth	1	2	3 + 4	
Fifth	1 + 2		3 + 4	
Sixth	1 + 2 + 3			4
Seventh	1	2 + 3 + 4		
Eighth	1 + 2 + 3 + 4			

- In all cases, residual fixed charge component will be added to the fixed charge component to create a single fixed charge.

18.19 Not used.

18.20 Not used.

18.21 Not used.

18.21A The fixed adder for a Non-Final Demand Site shall be zero.

19. APPLICATION OF EDCM CHARGES FOR EDCM CONNECTEES

19.1 The tariff application rules for the EDCM are the same as for the CDCM wherever possible. Each component of each tariff is rounded to the nearest value with no more than three decimal places in the case of unit rates expressed in p/kWh, and with no more

than two decimal places in the case of fixed and capacity charges expressed in p/day and p/kVA/day respectively.

19.2 The part of EDCM portfolio tariffs (for LDNO networks and Distribution Licence exempt networks) that is based on CDCM tariffs will be billed like CDCM tariffs.

19.3 Final EDCM demand charges will have:

1. an import fixed charge (in p/day)
2. an import capacity charge (in p/kVA/day)
3. an import super-red unit rate charge (in p/kWh)
4. an exceeded import capacity charge (in p/kVA/day).

19.4 The import fixed charge for each EDCM Connectee in p/day would be calculated as follows:

EDCM import fixed charge (p/day) = [LRIC fixed charge on sole use assets in p/day] + [residual fixed charge in p/day]

19.5 The final EDCM import capacity charge for each EDCM Connectee in p/kVA/day would be calculated as follows:

EDCM import capacity charge (p/kVA/day) = [LRIC p/kVA/day capacity charge] + [Transmission exit charge p/kVA/day] + [Network rates and direct costs charge in p/kVA/day] + [Indirect costs charge in p/kVA/day]

19.6 The final EDCM super-red unit rate in p/kWh is the LRIC super-red unit rate as calculated as described earlier in this document.

19.7 If the EDCM import capacity charge (p/kVA/day) calculated above is negative and the Connectee's average kW/kVA (adjusted for part year) is not equal to zero, the final EDCM super-red unit rate is adjusted as follows:

Adjusted LRIC super-red unit rate in p/kWh = [LRIC super-red rate in p/kWh] + ([EDCM import capacity charge (p/kVA/day)] * ([Days in the Charging Year] – [Days for which not a customer]) / [Average kW/kVA] / ([hours in the super-red time band] - [Hours in super-red for which not a customer]))

- 19.8 Finally, any remaining negative import super-red unit rates or import capacity charges are set to zero.
- 19.9 Final EDCM export charges will have:
1. An export fixed charge on sole use assets (in p/day)
 2. An export capacity charge (in p/kVA/day), which might include transmission exit credits to qualifying generators.
 3. An export super-red unit rate (in p/kWh)
 4. An exceeded export capacity charge (in p/kVA/day)
- 19.10 The export capacity charge (in p/kVA/day) is applied to the Chargeable Export Capacity of EDCM Connectees.
- 19.11 The export super-red unit rate (in p/kWh) is applied to active power units exported during the DNO Party's super-red time band.

20. EXCEEDED CAPACITY CHARGES

- 20.1 Where a Connectee uses additional capacity over and above the Maximum Import Capacity or Maximum Export Capacity without authorisation, the excess is classed as exceeded capacity.
- 20.2 For the purposes of determining capacity used, the following formula is used for each half hour:

$$\text{Import capacity used} = 2 * (\text{SQRT}(\text{AI}^2 + \text{MAX}(\text{RI}, \text{RE})^2))$$

Where:

AI = Import consumption in kWh

RI = Reactive import in kVArh

RE = Reactive export in kVArh

$$\text{Export capacity used} = 2 * (\text{SQRT}(\text{AE}^2 + \text{MAX}(\text{RI}, \text{RE})^2))$$

Where:

AE = Export production in kWh

RI = Reactive import in kVArh

RE = Reactive export in kVArh

- 20.3 For the purposes of calculating exceeded capacity for import charges, any reactive flows during half hours when there is no active power import would not be taken into account.
- 20.4 For the purposes of calculating exceeded capacity for export charges, any reactive flows during half hours when there is no active power export will not be taken into account.
- 20.5 Any reactive flows associated with a site which operates subject to grid code requirements for generation or sites providing voltage control at the request of the DNO Party would not be taken into account when calculating import or export capacity used.
- 20.6 For Connectees other than those that have an agreement with the DNO, the terms of which require them, for the purposes of P2/6 compliance, to export power during supergrid transformer (SGT) outage conditions, the exceeded portion of the export capacity is charged at the same rate as the capacity that is within the Maximum Export Capacity. This is charged for the duration of the month in which the breach occurs.
- 20.7 For Connectees other than those with DSM agreements, the exceeded portion of the import capacity is charged at the same rate as the capacity that is within the Maximum Import Capacity. This is charged for the duration of the month in which the breach occurs.
- 20.8 Sites subject to DSM arrangements would normally pay the DSM-adjusted capacity charge for capacity usage up to their Maximum Import Capacities.
- 20.9 If sites with DSM agreements were to exceed their maximum import capacities, the exceeded portion of the capacity will be charged at a different rate. This will be charged for the duration of the month in which the breach occurs. This charge for exceeded capacity (in p/kVA/day) would be determined as follows;

[Exceeded capacity charge in p/kVA/day] = [Import capacity charge p/kVA/day] +
 ((([LRIC capacity charge p/kVA/day] + ([LRIC super-red rate p/kWh] * [Average
 kW/kVA adjusted for part year] * [super-red hours] / ([days in Charging Year] –
 [Days for which not a customer]))) * (1 - ([chargeable capacity]/ [Maximum Import
 Capacity])))

Where:

The LRIC super-red unit rate and LRIC capacity charges in the equation above are the charges before any adjustments for DSM have been made.

21. APPLICATION OF EDCM IMPORT CHARGE COMPONENTS

21.1 Table 21.1 summarises the method of application of import charge components.

Table 21.1 Application of EDCM import charge components

Tariff component	Unit	Application
Import fixed charge	p/day	Applied as a fixed charge.
Import capacity charge	p/kVA/day	Applied to the Maximum Import Capacity.
Exceeded import capacity charge	p/kVA/day	Applied to exceeded capacity for the duration of the month in which the breach occurs (except for sites which operates subject to grid code requirements for generation)
Import super-red unit rate	p/kWh	Applied to active power units consumed during the DNO Party's super-red time band.

21.2 Table 21.2 summarises the method of application of export charge components.

Table 21.2 Application of EDCM export charge components

Tariff component	Unit	Application
Export fixed charge	p/day	Applied as a fixed charge.
Export capacity charge	p/kVA/day	Applied to the Chargeable Export Capacity.

Exceeded export capacity charge	p/kVA/day	Applied to exceeded capacity for the duration of the month in which the breach occurs (except for sites which operates subject to grid code requirements for generation)
Export super-red unit rate	p/kWh	Applied to active power units exported during the DNO Party's super-red time band.

22. CHARGES FOR NEW CONNECTEES

- 22.1 New Connectees could connect at any time between the publication of EDCM charges for the new Charging Year and the end of that Charging Year.
- 22.2 If the connection of such Connectees had been anticipated before the publication of charges, the DNO Party would have included forecast data relating to the new Connectee in both the power flow model and the EDCM tariff model. The resulting tariff is applied to the new Connectee, on a pro-rata basis if the price is produced during the Charging Year.
- 22.3 If prices need to be produced for new connections that had not been anticipated at the time of calculating EDCM charges for that Charging Year, the DNO Party will:
- Seek indicative load profile information from the new Connectee, failing that, make a reasonable estimate;
 - Run the power flow model after including the new Connectee to produce a full set of charges 1 and 2, including for the new Connectee;
 - Include the new Connectee's details, including marginal charges from (a) in the EDCM tariff model, to produce a full set of new charges;
 - Use the tariff relating to the new Connectee to calculate charges; and
 - Charges relating to the current year for existing Connectees would not change as a result.
- 22.4 If a Connectee were to change their maximum import or export capacity at any time between the publication of EDCM charges for the Charging Year and the end of the

Charging Year, the published tariff rates would continue to apply for the duration of the Charging Year.

23. DNO TO DNO CHARGES

- 23.1 In the case of DNO Party to DNO Party interconnections, the interconnections are categorised into four types:
- (a) The interconnector between the DNO Parties is normally closed (active), and there is an identifiable benefit from the existence of the interconnection to one DNO Party only. The other DNO Party does not benefit from the interconnection.
 - (b) The interconnector is normally closed (active), and there is either an identifiable benefit to both DNO Parties, or no clear benefit to either DNO Party.
 - (c) The interconnector is normally open, and the interconnection exists only to provide backup under certain conditions to either DNO Party.
 - (d) All other interconnections between DNO Parties.
- 23.2 In all cases of type (a), the benefitting DNO Party will be treated as being equivalent to an EDCM Connectee connected to the other DNO Party's network. The DNO Party providing the benefit will calculate and apply EDCM import charges, except charges for sole use assets, as applicable to the other DNO Party. Export charges or credits will not apply.
- 23.3 In the case of type (b) interconnections, each DNO Party will treat the other as an EDCM Connectee. Normal EDCM import charges, except charges for sole use assets, will apply. Export charges or credits will not apply.
- 23.4 Type (c) interconnections are typically covered by special arrangements between DNO Parties. Use of system charges are agreed between DNO Parties and applied outside the EDCM model.
- 23.5 In every other case, each DNO Party applies import charges to the other as a normal EDCM Connectee, as with type (b) interconnections.

24. LDNO CHARGING

- 24.1 LDNOs with Distribution Systems that serve Connectees that fall within the scope of the CDCM would have their charges based on standard discount percentages applied to the CDCM all-the-way end user charges.

A LDNO with a Distribution System that qualifies as a CDCM “Designated Property” according to the definition set out in condition 13A.6 of the Distribution Licence is eligible for portfolio discounts calculated using the price control disaggregation model provided for under Schedule 29, with any subsequent adjustment applied in respect of the DNO Party's Supplier of Last Resort and Eligible Bad Debt pass-through costs as described in paragraphs 100 to 104 of the CDCM.

A LDNO with a Distribution System that qualifies as an EDCM “Designated EHV Property” according to the definition set out in condition 13B.6 of the Distribution Licence is eligible for discounts calculated using the price control disaggregation model provided for under Schedule 29, with any subsequent adjustment applied in respect of the DNO Party's Supplier of Last Resort and Eligible Bad Debt pass-through costs as described in paragraphs 100 to 104 of the CDCM.

- 24.2 A LDNO with a Distribution System that qualifies as an EDCM “Designated EHV Property” could itself have Connectees who would fall under the scope of the EDCM. Since the EDCM is a locational charging method, the host DNO Party would calculate EDCM charges at the DNO Party’s boundary for each EDCM-like Connectee on the LDNO’s Distribution System. No discounts are calculated for such EDCM Connectees as the DNO Party’s charges are based only on the specific site’s equivalent use of the DNO Party’s Distribution System.

25. CALCULATION OF LDNO DISCOUNTS

- 25.1 The discount percentages are determined in accordance with Schedule 29, which is deemed to form part of this EDCM (as if it were set out herein).
- 25.2 In each case, the discount applied to all CDCM tariff components. Discount percentages are capped to 100 per cent.
- 25.3 Supplier of Last Resort pass-through costs are allocated by applying a fixed charge adder (p/day) to the following customer groups, as calculated under paragraph 102 of the CDCM:
- LDNO HVplus: Domestic Aggregated or CT;
 - LDNO EHV: Domestic Aggregated or CT;
 - LDNO 132kV/EHV: Domestic Aggregated or CT;
 - LDNO 132kV: Domestic Aggregated or CT;
 - LDNO 0000: Domestic Aggregated or CT.
- 25.4 Eligible Bad Debt pass-through costs are allocated by applying a fixed charge adder (p/day) to all metered demand tariffs excluding ‘related MPAN’ tariffs, as calculated under paragraph 103 of Schedule 16.
- 25.5 Not used.
- 25.6 Not used.
- 25.7 Not used.
- 25.8 Not used.
- 25.9 Not used.
- 25.10 Not used.
- 25.11 Not used.

- 25.12 Not used.
- 25.13 Not used.
- 25.14 Not used.
- 25.15 Not used.
- 25.16 Not used.
- 25.17 Not used.
- 25.18 Not used.
- 25.19 Not used.

26. PORTFOLIO EDCM TARIFFS FOR CONNECTEES IN THE EDCM

- 26.1 For Connectees on a LDNO's Distribution System that would be covered by the EDCM if they were on the DNO Party's Distribution System, the EDCM is applied to calculate a portfolio EDCM charge/credit for each such Connectee.
- 26.2 These EDCM portfolio charges would be calculated as if each EDCM Connectee on the LDNO's Distribution System were notionally connected at the boundary between the DNO Party and the LDNO; except for LDNO UMS tariffs, which are charged by reference to the voltage of the Points of Connection that provide the majority of the energised domestic connections for the LDNO in the GSP Group (or, where there is no such majority, on such other reasonable basis as the DNO Party determines). Both EDCM import and export charges will apply.
- 26.3 For the purposes of calculating the boundary-equivalent portfolio EDCM tariffs, each EDCM Connectee on the LDNO's Distribution System would be assigned the demand Connectee category determined by reference to that LDNO Distribution System's Point of Common Coupling. The demand Connectee category is assigned as per Table 15.6.
- 26.4 Such Connectees would attract charges (credits) in respect of any reinforcements caused (avoided) on the DNO Party's Distribution System only, i.e. any network

Branches that are on the LDNO's Distribution System would be attributed a zero LRIC charge/credit.

- 26.5 The setting of final charges to Embedded Designated EHV Properties including the calculation of charges for assets used on the LDNO's Distribution System will be established by the LDNO.
- 26.6 All EDCM charges would be calculated using "boundary equivalent" data provided by the LDNO to the host DNO Party for each Embedded Designated EHV Property. For the purposes of the EDCM, boundary equivalent data should be what the LDNO has allowed for at the DNO Party - LDNO boundary, for each EDCM Connectee, after taking into consideration the diversity and losses within the LDNO's Distribution System. Data relating to CDCM end users must be considered for the purposes of calculating boundary equivalent data in order to cater for the effect of diversity and losses.
- 26.7 The EDCM will include in the charges for Embedded Designated EHV Properties a fixed charge relating to any assets on the DNO Party's Distribution System that are for the sole use of a LDNO Party's Distribution System. The assets on the DNO Party's network that are for the sole use of a LDNO Distribution System are defined as the assets in which only consumption or output associated with Embedded customers on the LDNO Distribution System can directly alter the power flow in the asset, taking into consideration all possible credible running arrangements, i.e. all assets between the asset ownership boundary and the LDNO Distribution System's Point of Common Coupling are considered as sole use assets. These fixed charges would be calculated in the same way as it would be for EDCM Connectees connected directly to the host DNO Party's Distribution System.
- 26.8 In calculating charges for assets on the DNO Party's Distribution System that are for the sole use of a LDNO's Distribution System, DNO Party's will charge only for the proportion of sole use assets deemed to be used by Embedded Designated EHV Properties. This proportion will be calculated, in respect of each Embedded Designated EHV Properties, as the ratio of the boundary equivalent capacity of that Connectee to the capacity at the LDNO - DNO Party boundary.

- 26.9 If there are no Embedded Designated EHV Properties on the LDNO's Distribution System, no sole use asset charges would apply.
- 26.10 Demand scaling would be applied as normal to any EDCM portfolio tariff in respect of an EDCM Connectee. For the purposes of scaling, all EDCM Connectees connected to the LDNO's Distribution System will be treated as notional EDCM Connectees connected to the DNO Party's Distribution System with a Point of Common Coupling at the LDNO Distribution System's Point of Common Coupling.
- 26.11 For EDCM Connectees connected to the LDNO's Distribution System, the capacity-based charge for the DNO Party's indirect costs and 20% of the residual fixed charge for the EDCM Connectee, would be scaled down by a factor of 50 per cent, however, the scaling down will not apply where the residual revenue is negative.

27. OFFSHORE NETWORKS CHARGING

- 27.1 The DNO Party will treat offshore networks connected to the DNO Party as if they were EDCM Connectees.
- 27.2 The DNO Party will apply the EDCM to calculate an import charge and an export charge based on capacity at the boundary and power flow data metered at the boundary.
- 27.3 Any sole use assets specific to the offshore network are charged as a p/day sole use asset charge calculated as applicable to a normal EDCM Connectee.
- 27.4 Demand scaling will also be applied.

28. DNO PARTY TO UNLICENSED NETWORKS

- 28.1 Unlicensed networks have a choice. If they are part of the Total System under the Balancing and Settlement Code with the network open to supply competition, and if they are party to the DCUSA, and have accepted the obligations to provide the necessary data, they can, if they wish, be treated as LDNOs.
- 28.2 Otherwise, the DNO Party applies the EDCM to calculate an import charge and an export charge based on capacity and power flow data metered at the boundary. Any

sole use assets specific to the unlicensed network are charged as a p/day sole use asset charge calculated as applicable to a normal EDCM Connectee.

29. DERIVATION OF 'NETWORK USE FACTORS'

Step 1:

29.1 Powerflow analysis is used to determine the change in powerflow in each Branch (in MW) that is caused by a change in load (in MW) at each node in the EHV network model, that represents either EDCM demand or CDCM demand at the EHV/HV boundary.

29.2 In essence, a change in load of X MW is applied at the node under consideration and changes in powerflow in each network Branch are identified. If the change in powerflow in a particular Branch is Y MW, as a result in the change in load at the node under consideration, then the 'Change In Branch Flow per Change In Demand' is given by:-

Abs (Y/X) (MW Branch flow per MW of demand at node)

29.3 The effects of a change in demand at each node, upon the powerflows in Branches, are evaluated for each node in turn.

29.4 The method of evaluating the 'Change in Branch Flow per Change in Demand' shall be the Incremental Method, described below:

30. INCREMENTAL METHOD:

30.1 Establish the 'base case' powerflow in each Branch using a network model constructed with demand data used to represent the Maximum Demand Scenario analysed in the marginal cost calculation, using Maximum Demand Data that represents the regulatory year that use of system charges are being calculated for.

30.2 Apply a 0.1MW (at 0.95 lagging p.f.) increment to each node, in turn, in the EHV network model (at nodes that represent either an EDCM Connectee or CDCM demand at the EHV/HV boundary) and identify the change in powerflow (in MW) in all Branches where the change exceeds both 1kVA and 0.01% of the 'base case' powerflow

in the Branch. The change in Branch flow corresponding to a 0.1MW increment at a node can be evaluated by actual application of an increment to the network model, or through the use of sensitivity coefficients. Prior to the application of the increment all the transformer tap positions, distributed generation outputs and switched shunt values are fixed to the values determined in the ‘base case’ powerflow to prevent change in their values when analysing the power flows with the increment applied.

- 30.3 This calculation is performed upon the Authorised Network Model and only considers normal running arrangements.

Step 2:

- 30.4 The ‘MW usage’ of each Branch by a given nodal demand is determined by multiplying the relevant value of ‘Change In Branch Flow per Change In Demand’ (derived in step 1) by the demand at the node (MW) as used in the Maximum Demand Scenario for the marginal cost calculation, using the Maximum Demand Data that represents the regulatory year that use of system charges are being calculated for. This will always be a positive quantity.

Step 3:

- 30.5 For each Branch, the ‘total MW usage’ of the Branch by all nodal demands is determined by summing the ‘MW usage of the Branch’ by each node (as determined in step 2).

Step 4:

- 30.6 Each nodal demand’s proportionate usage of a Branch is determined using the equation below:

$$\text{Alloc (£/year)} = ([\text{MW usage}] / [\text{Total MW usage}]) * (\text{Abs} [\text{Max contingency flow}] / [\text{Rating}]) * \text{AMEAV}$$

If the Branch is “generation-dominated”, or $(2 * \text{Abs} [\text{Base flow load}]) \leq \text{Abs} ([\text{Base flow}] - [\text{Base flow load}])$, then use:

$$\text{Alloc (£/year)} = ([\text{MW usage}] / [\text{Total MW usage}]) * (\text{Abs} [\text{Max contingency flow}] / [\text{Rating}]) * \text{Abs} ([\text{Base flow load}] / [\text{Base flow}]) * \text{AMEAV}$$

Where:

- Alloc is the allocation of the AMEAV of the asset to a demand user in £/year
- MW usage is the absolute value of the “MW usage” of the asset attributable to that demand user (expressed in MW)
- Total MW usage is the sum of the absolute values of the “MW usage” of all demand users of that asset (expressed in MW)
- Max contingency flow is the maximum post-contingent flow through the asset in MVA. The maximum post-contingency asset flows may be extracted from the ‘locational’ analyses.
- Rating is the unadjusted rated capacity of the asset in MVA
- Base flow load is the algebraic sum of power flows through the Branch due to demand only in MW.
- Base flow is the aggregate power flow through the Branch under normal network operation in MW.
- AMEAV is the annualised modern equivalent asset value in £/year of that asset.
- The ratio ($[\text{Max contingency flow}] / [\text{Rating}]$) is called the asset utilisation factor and it is capped at 1.

The quantity $(\text{Abs} [\text{Max contingency flow}] / [\text{Rating}]) * \text{Abs} ([\text{Base flow load}] / [\text{Base flow}])$ is called the load utilisation factor.

30.7 Sole use assets are not to be included in the calculation of the MEAV of the Branches and consequently some Branches may have an MEAV of zero.

Step 5:

30.8 For each node, the £/annum ‘usage’ of Branches (calculated in Step 4) of the same voltage level, by the demand at the node, are summated to create a total £/annum for each voltage level for the nodal demand. The considered voltage levels correspond to those used in the CDCM and include voltage levels that represent transformation

between two voltages. These voltage levels are ‘132kV’, ‘132kV/EHV’, ‘EHV’, ‘EHV/HV’ and ‘132kV/HV’.

- 30.9 For each node where EDCM demand is present, the total £/annum ‘usage’ of Branches of each voltage level, for the node, is divided by the demand at the node (in kW), as used in the Maximum Demand Scenario, to create a £/kW/annum total usage of Branches at each voltage level by the particular node. This shall be the numerator in the network use factor, for a particular voltage level, for the EDCM demand node.
- 30.10 For all nodes where CDCM demand is present, and the CDCM demand is considered to be ‘dominant’ at the node (CDCM demand shall be considered to be ‘dominant’ where the DNO Party estimates that the maximum demand associated with all CDCM demand at the node exceeds the maximum demand associated with all EDCM demand at the node), the £/annum ‘usages’ of Branches at each voltage level (calculated in Step 4) are summated to create a total £/annum ‘usage’ for all CDCM dominated nodes. The CDCM demand ‘using’ each voltage level is determined by summing the nodal demands of all CDCM dominated nodes that have non zero £/annum ‘usages’ at the particular voltage level. The average £/kW/annum network usage by CDCM dominated nodes is derived for each voltage level by dividing the total £/annum usage (at the voltage level by CDCM dominated nodes) by the total CDCM demand ‘using’ the voltage level. This provides the denominators used for the network use factors.
- 30.11 The network use factor, at each voltage level, for each node where EDCM demand is present therefore is the £/kW/annum for the nodal demand at the appropriate voltage level, divided by the corresponding average £/kW/annum for the same voltage level determined for CDCM dominated nodes.

SCHEDULE 18 – EHV CHARGING METHODOLOGY (LRIC MODEL)**ANNEX 1 – IMPLEMENTATION GUIDE****1. SCOPE**

- 1.1 This Annex describes the definitions, input and output data, and the power flow analysis process required to model the DNO Party's Distribution System to enable the LRIC methodology to be implemented as set out in the EDCM.

2. POWER SYSTEMS ANALYSIS**Power Flow Analysis Tools**

- 2.1 The DNO Parties use a variety of software tools to model their respective Distribution Systems for the purposes of operating and planning their Distribution Systems.
- 2.2 The Authority and the DNO Parties have agreed that it is not appropriate to prescribe which software tool is used for the analysis of the Distribution Systems, as it is for each DNO Party to satisfy itself that it is using the appropriate tools for planning and operation of its Distribution System.
- 2.3 The DNO Parties routinely analyse their Distribution Systems using power system analysis tools to identify where limitations exist on the network; this information is used to plan reinforcement. The DNO Parties hold current representations of their Distribution Systems within their respective power system analysis tools for this analysis. The aim of using power flow analysis for pricing purposes is to replicate the reinforcement assessment process to determine the costs of future reinforcement of the DNO Party's Distribution System. Analysing the Distribution System at this level of granularity enables the creation of Nodal costs that can be used to convey cost messages at the Nodal level if desirable.

Power Flow Analysis for Incremental Costing

- 2.4 Planning of a Distribution System (to satisfy the requirements of the Act and the Distribution Licences) using a power system analysis tool requires the development of a network model which represents the actual Distribution System and the application

of a set of demand data that represent the demands that the network will be required to deliver whilst satisfying the nationally defined security standard, ER P2/6.

- 2.5 These following sections describe the definitions, input data, and the power flow analysis process required to model the DNO Party's Distribution System for incremental costing purposes. The calculation of reinforcement cost and the main outputs are discussed at the end of this Annex.

3. DEFINITIONS

3.1 In this Schedule 18, unless the context otherwise requires, the expressions below shall have the meanings set out below.

Term	Definition
Active Power	The product of the voltage, current and cosine of the phase angle between them, measured in watts.
Allowed Revenue	The amount of revenue that the DNO Party can earn on its regulated business in accordance the special conditions within the DNO Party's Distribution Licence.
Authorised Network Model	The model that represents the DNO Party's entire EHV network (from the GSP level down to and including the HV busbar at the EHV/HV transformation level), as described in Paragraph 2.7(a) and section 4 of this Annex 1.
Base Case Analysis	The analysis to determine the utilisation of the Authorised Network Model under Normal Running Arrangements. Note the Base Case Analysis is performed for each demand scenario (the Maximum Demand Scenario and the Minimum Demand Scenario).
Base Case Flows	The power flows in each Branch as determined under Base Case Analysis. Base Case Flow _b is the power flow in Branch b. Note a separate set of Base Case Flows is determined for each demand scenario (the Maximum Demand Scenario and the Minimum Demand Scenario).
Branch	A representation of an asset, collection of assets or part of an asset of the DNO Party's EHV network through which Active Power flows as a consequence of supply to or export from a Connectee or busbar on the DNO Party's

HV or EHV networks. A Branch must only be connected between two Nodes. A Branch should conform to the following:

- there can be more than one Branch between the same two Nodes;
- a three winding transformer may be represented by three Branches (one Branch for each of the windings) configured in a star formation;
- the Active Power flowing out of one end of a Branch should equal the Active Power flowing into the other end of the Branch less any losses within the Branch;
- shunt reactors and capacitors are not Branches;
- earthing transformers, resistors and reactors are not Branches; and
- a Branch may constitute a collection of assets e.g. a circuit constituting overhead lines and cables. When combining assets into a Branch, there is a need to consider the reinforcement solution for the Branch in the next stages for the incremental costing calculation.

Branch Rating	The branch ratings selected for the Authorised Network Model should be derived by appropriate consideration of the time of day/ season/ general nature of load profile (i.e. continuous, cyclic etc.) represented within the model.
Bulk Supply Point (BSP)	A supply point on the DNO Party's Distribution System representing an EHV/EHV transformation level e.g. 132/33kV.
Charging Year	The financial year (12 month period ending on a 31st March) for which charges and credits are being calculated.
Circuit	The part of a Distribution System between two or more circuit breakers, switches and/or fuses inclusive. For the

avoidance of doubt a circuit can contain a number of Branches and Nodes. A Circuit may include transformers, reactors, cables and overhead lines. Busbars are not considered as Circuits.

Circuit Branch

A categorisation, used in the derivation of Branch reinforcement costs, for Branches that represent an interconnection (or part of an interconnection) between substations and which operate at a single voltage level.

Connection Node

A Node which is a point of connection to one of the following:

- an Entry Point or the Sole Use Assets connecting the Entry Point; or
- an Exit Point or the Sole Use Assets connecting the Exit Point; or
- the DNO Party's HV network; or
- a Distribution System of another DNO Party or IDNO Party.

Contingency Analysis

The analysis to determine the effect on power flow on the Authorised Network Model under N-1 Contingencies. Note that Contingency Analysis is performed for each demand scenario (the Maximum Demand Scenario and the Minimum Demand Scenario).

Diversity Allowance

The extent, expressed as a percentage, to which the sum of the maximum load across all assets in the modelled network level is expected to exceed the simultaneous maximum load for the network level as a whole.

Diversity Factor

A scaling factor calculated as the ratio of the maximum demand observed at a given location on the network and the aggregate of the individual maximum demands observed at multiple locations connected downstream (i.e.

further from source) of the given location, taking account of losses. Such factors provide a means of recognising that the maximum demands observed at individual locations (e.g. substations at a given voltage level) on a section of network may not be coincident. Details of the calculation of Diversity Factors are set out in section 5.11 (Diversity Factors) of Annex 1.

EDCM

has the meaning given to that expression in Paragraph 1.

EDCM Connectee

means a Connectee whose Connected Installation is a Designated EHV Property as defined in Standard Conditions 50A.11 and 13B.6 of the DNO Party's Distribution Licence.

EHV

Extra High Voltage.

Electricity Ten Year Statement (ETYS)

This is the statement of that name required to be produced by the Independent System Operator and Planner under the Electricity System Operator Licence in respect of the whole of Great Britain. The statement includes information on demand, generation, plant margins, the characteristics of the existing and planned National Electricity Transmission System, its expected performance and capability now and in the future.

Eligible Bad Debt

means any bad debts with respect to Use of System Charges that the DNO Party can recover in accordance with the DNO Party's Distribution Licence. For the avoidance of doubt, this definition includes the DNO Party's bad debt and bad debt which the DNO Party is recovering on behalf of LDNOs.

Embedded

means connected to a LDNO's Distribution System.

ER P2/6	Energy Network Association's Engineering Recommendation P2/6 which is the planning standard for security of supply to be used by the DNO Parties.
ETR 130	Energy Network Association's Engineering Technical Report 130 which is the Application Guide for assessing the capacity of Distribution Systems to which Generation Installations are connected.
Extra High Voltage (EHV)	Refers to voltages operating at 22kV or higher.
Forecast Business Plan Questionnaire or FBPQ	means the questionnaire that the DNO Party is required to submit under the Regulatory Instructions and Guidance issued by the Authority under the DNO Party's Distribution Licence.
Generation Coincidence Factor	A factor which is calculated for each Grid Supply Point (or group of normally interconnected Grid Supply Points) and applied to Network Demand Data (Generation) in the Minimum Demand Scenario, to reflect the coincidence of generation export.
Grid Supply Point (GSP)	A point of supply from the National Electricity Transmission System to the DNO Party's Distribution System.
High Voltage (HV)	Refers to voltages operating above 1000 volts but lower than 22kV.
Incremented Flow Analysis	The analysis to determine the effects of a demand increment or decrement at a Node on each Branch of the Authorised Network Model under Normal Running Arrangements. Note the Incremented Flow Analysis is performed for each demand scenario (the Maximum Demand Scenario and the Minimum Demand Scenario).

Incremented Flows	The new power flows in each Branch as a consequence of the effect of a specified increment of demand at each Node. A separate set of Incremented Flows is produced for each demand scenario. The specified increment of demand at each Node may be different for each demand scenario. Incremented Flow _{nb} is the new power flow in Branch b as a result of a change of demand at Node n.
Iterative Approach	A numerical approach for the calculation of Incremented Flows. The approach is described in section 6.21 (Iterative Approach) of Annex 1.
kV	Kilovolt (1,000 Volts): a unit of voltage.
kVA	Kilo Volt Ampere: a unit of network capacity.
kVAr	Kilo Volt Ampere reactive: a unit of reactive power flow. The network capacity used by a flow of A kW and B kVAr is $\text{SQRT}(A^2+B^2)$ kVA.
kVArh	kVA reactive hour: a unit of total reactive power flow over a period of time. Reactive power meters usually register kVArh.
kW	Kilowatt (1,000 Watts): a unit of power flow.
kWh	Kilowatt hour: a unit of energy. Meters usually register kWh.
LDNO	refers to a licensed distribution network operator, meaning an IDNO Party or a DNO Party operating an electricity distribution system outside of its Distribution Services Area.
Long Term Development Statement (LTDS)	The Long Term Development Statement as detailed by Licence Condition 25 of the Distribution Licences.

LRIC	Has the meaning given to that expression in Paragraph 2.1.
LV	Nominal voltages of less than 1kV.
Maximum Contingency Flows	The maximum power flows in each Branch as determined under Contingency Analysis. Maximum Contingency Flow _b is the maximum power flow in Branch b under all N-1 Contingencies for the demand scenario. Note a separate set of Maximum Contingency Flows is determined for each demand scenario (the Maximum Demand Scenario and the Minimum Demand Scenario).
Maximum Demand Data	The Network Demand Data that is applied to the Maximum Demand Scenario. The construction of Maximum Demand Data is described in section 5.31 (Maximum Demand Data for the Authorised Network Model) of Annex 1.
Maximum Demand Scenario	The analysis scenario of the Authorised Network Model populated with demands that reflect maximum loading conditions.
Minimum Demand Data	The Network Demand Data that is applied to the Minimum Demand Scenario. The construction of Minimum Demand Data is described in section 5.37 (Minimum Demand Data for the Authorised Network Model) of Annex 1.
Minimum Demand Scenario	The analysis scenario of the Authorised Network Model populated with demands that reflect minimum loading conditions.
MVA	Mega Volt Ampere (1,000 kVA): a unit of network capacity.
MW	Megawatt (1,000 kW): a unit of power flow.

MWh	Megawatt hour (1,000 kWh): a unit of energy. Energy trading is usually conducted in MWh.
N-1 Contingency	An N-1 Contingency considers an N-1 Event occurring on the Authorised Network Model and models the consequential network actions and where appropriate constraints on Connectee demands to ensure that the flow on each Branch is within its rated capacity and so is ER P2/6 compliant.
N-1 Event	An N-1 Event is a First Circuit Outage (FCO) as explained in ER P2/6. It signifies a fault or arranged outage on the network which would result in a section of the network defined by the relevant protection scheme to sectionalise and isolate the faulty section, or isolate the section to be worked on for maintenance, resulting in zero power flow in the affected network. N-1 Events should consider an outage of a complete Circuit and only consider faults or arranged outages occurring with the network initially running under Normal Running Arrangements.
National Electricity Transmission System	Has the meaning given to that expression in the CUSC
Negative Load Injection	Negative Load Injection is a negative value of load calculated and applied to a source substation within the network model to represent the effects of diversity between associated downstream demands upon the actual demand observed at the source substation.
Net Diversity Factor	A scaling factor that represents the diversity between the maximum demands observed at substations at different levels of a network, which may be derived by multiplying Diversity Factors representing the diversity between interim levels.

network	This is a reference to the DNO Party's Distribution System, or to a particular part of that Distribution System.
Network Demand Data	This is the load and generation which is used to populate the Authorised Network Model. Network Demand Data is constructed of Network Demand Data (Load) and Network Demand Data (Generation). A description of Network Demand Data is given in section 5 of (Network Demand Data) of Annex 1.
Network Demand Data (Generation)	Generation export applied within the Authorised Network Model at Nodes representing the Entry Point for each EDCM Connectee with an agreed Maximum Export Capacity, factored according to ER P2/6 or coincidence with other generation export, where appropriate.
Network Demand Data (Load)	The load applied within the Authorised Network Model at Nodes representing the Exit Point for each EDCM Connectee and/or the lower voltage busbars at each EHV/HV substation.
network level	The network is modelled as a stack of circuit and transformation levels between supplies at LV and the National Electricity Transmission System. A network level is any circuit or transformation level in that stack. An additional network level is used for transmission exit.
Node	<p>A representation of a point on the DNO Party's EHV network that is a point of connection between a Branch and one or more of the following:</p> <ul style="list-style-type: none"> • another Branch; or • an Entry Point or the Sole Use Assets connecting the Entry Point; or • an Exit Point or the Sole Use Assets connecting the Exit Point; or

- the DNO Party’s HV network; or
- the Distribution System of another DNO Party or IDNO Party; or
- the National Electricity Transmission System,
- and “Nodal” shall be construed accordingly.

Non-Final Demand Site	as defined in Schedule 32
Normal Running Arrangements	The DNO Party’s network with no system outages i.e. with no planned outages (e.g. for maintenance) and no unplanned outages (e.g. subsequent to a fault).
Off-Peak Charge	The Nodal marginal charge (£/kVA/annum) calculated for the Minimum Demand Scenario. The calculation of this Nodal marginal charge is discussed in section 8 (Output results) of Annex 1.
Peak Charge	The Nodal marginal charge (£/kVA/annum) calculated for the Maximum Demand Scenario. The calculation of this Nodal marginal charge is discussed in section 8 (Output results) of Annex 1.
Point of Common Coupling	The Point of Common Coupling for a particular single Connectee is the point on the network where the power flow associated with the single Connectee under consideration, may under some (or all) possible arrangements interact with the power flows associated with other Connectees, taking into account all possible credible running arrangements.
Power factor	The ratio of energy transported (kW) to network capacity used (kVA).
Portfolio tariff	A tariff for use of the network by another DNO/IDNO Party where charges are linked to flows out of/into the

other DNO/IDNO Party's network from its Connectees or further nested networks.

Reactive Power	The product of the voltage and current and the sine of the phase angle between them, measured in units of voltamperes reactive.
Recovery Factor	A factor which is applied to the Branch incremental costs to limit the level of Branch cost recovery to being no greater than the actual reinforcement cost of the Branch.
Regulatory Year	Has the meaning given to that expression in the DNO Party's Distribution Licence.
RRP	Regulatory reporting pack, a dataset produced each year by each DNO Party for the Authority.
Scaling Factor	A factor which is calculated for each Grid Supply Point (or group of normally interconnected Grid Supply Points) to calculate the Network Demand Data (Load) element of the Minimum Demand Data.
Security Factor	These describe the change in utilisation of Branches between the Maximum Contingency Flows determined by Contingency Analysis and the Base Case Flows determined by Base Case Analysis. Section 6.6 (Security Factor Calculation) of Annex 1 describes how Security Factors are calculated.
Sensitivity Coefficients Approach	An analytical approach for the calculation of Incremented Flows, which approach is described in section 6.23 (Sensitivity Coefficients Approach) of Annex 1.
Sole Use Assets	Sole Use Assets are assets in which only the consumption or output associated with a single Connectee can directly alter the power flow in the asset, taking into consideration all possible credible running arrangements, i.e. all assets

	between the Connectee's Entry/Exit Point(s) and the Point(s) of Common Coupling with the general network.
Supplier of Last Resort	a supply licensee to which a Last Resort Supply Direction applies, where Last Resort Supply Direction has the meaning given to that expression in the Supply Licence.
System simultaneous maximum load	The maximum load for the GSP Group as a whole.
Transformer Branch	A categorisation used in the derivation of Branch reinforcement costs, for Branches that represent transformation between different voltage levels.
unit	Where the context permits, the word unit refers to kWh.
unit rate	A charging or payment rate based on units distributed or units generated. Unit rates are expressed in p/kWh. Tariffs applied to multi-rate meters and/or using several time bands for charging have several unit rates.

4. NETWORK MODELLING

4.1 This section 4 describes the input data required to model the DNO Party's Distribution System for pricing purposes.

Authorised Network Model

4.2 This is the network model that represents the DNO Party's entire EHV network, from the GSP level down to and including the HV busbar at the EHV/HV transformation level and includes all authorised (i.e. sanctioned by the DNO Party) reinforcement, replacement, diversion and new connection works that are anticipated to be constructed and operational at the time of Maximum Demand in the year for which the Use of System Charges are being calculated.

4.3 Due to the timings difference between the publication of the LTDS and the creation and publication of Use of System Charges, the Authorised Network Model may contain revised assumptions to the LTDS information. Where a part of a single authorised network project is expected to be commissioned and operational in the year for which Use of System Charges are to be calculated then the DNO Party may, if appropriate, model the fully completed network project.

4.4 The Authorised Network Model may be constructed so that power flow analysis may be conducted separately upon individual Grid Supply Points (or groups of normally interconnected Grid Supply Points) provided that there is no transfer of demand, or interconnection, with adjacent Grid Supply Points considered in the analysis of contingency conditions.

4.5 A representation of the National Electricity Transmission System shall be included in the model. The complexity of the representation will be dependent on the level of interconnection of Grid Supply Points via the DNO Party's EHV network. The representation may be:

- (a) a simple generator infeed at the Grid Supply Point; or
- (b) the use of equivalent circuits to model the interconnections of the Grid Supply Points via the National Electricity Transmission System; or

- (c) a full replication of the National Electricity Transmission System electrically local to the DNO Party's Distribution System; or
- (d) a full replication of the whole of the National Electricity Transmission System.
- (e) The method of representation should be carefully selected in order to produce a suitable representation of the flows into the DNO Party's EHV network from the National Electricity Transmission System during both Normal Running Arrangements and N-1 Contingency scenarios.

4.6 Where there is a connection between the DNO Party's EHV network and an IDNO Party's EHV network (or another DNO Party's EHV network), these can be represented either by an Exit Point or an Entry Point in a similar manner to that of an EDCM Connectee. In the event that the IDNO Party's (or other DNO Party's) network derives its supply from several different connection points on the DNO Party's Distribution System it may become necessary to model some or all of the IDNO Party's (or other DNO Party's) network to ensure that the flows at the boundary are representative of those expected under Normal Running Arrangements and Contingency scenarios.

4.7 The Authorised Network Model can be modelled so that it takes into account every different section of a Circuit, including individual underground cables and overhead line sections, with each different type forming a separate Branch in the model connected between two Nodes. However, this approach can lead to known issues associated with the non-convergence to a power flow solution of models with large numbers of Nodes and large numbers of Branches with very small impedances. It is acceptable to model a single Branch to represent a composite of multiple subcomponents of cable and overhead line. The impedance of a composite Branch can be calculated from the types of subcomponent that make up the overall Circuit length. The rating of a composite Branch can be obtained by examining the rating of all the Branch subcomponents and the lowest rating will be used as the limiting section that overloads first. For underground cables the impedance/rating is dependent upon the construction type of the cable, cross sectional area of the conductor, conductor material, whether the cable is laid directly in the ground or in ducts. Similarly, for overhead lines the impedance/rating is dependent upon the construction type of the overhead line structures (to take account of the relative positions of the conductors), the conductor material/type and

cross sectional area. This information can then be used to determine the Branch impedance and minimum component rating applied to the Branch in the network model.

- 4.8 As an example, if Figure 2 below represents the actual network, the approach described above to produce the EHV network model would reduce it to a Nodal model representation as shown in Figure 3 below.
- 4.9 Table 4.9 shows an example of the data held relating to Figure 2 with the individual subsections being cross referenced to each Branch. Table 4.9A lists the parameters used for the Nodal model shown in Figure 3.

Figure 2 - An example of a section of network to be converted into a model.

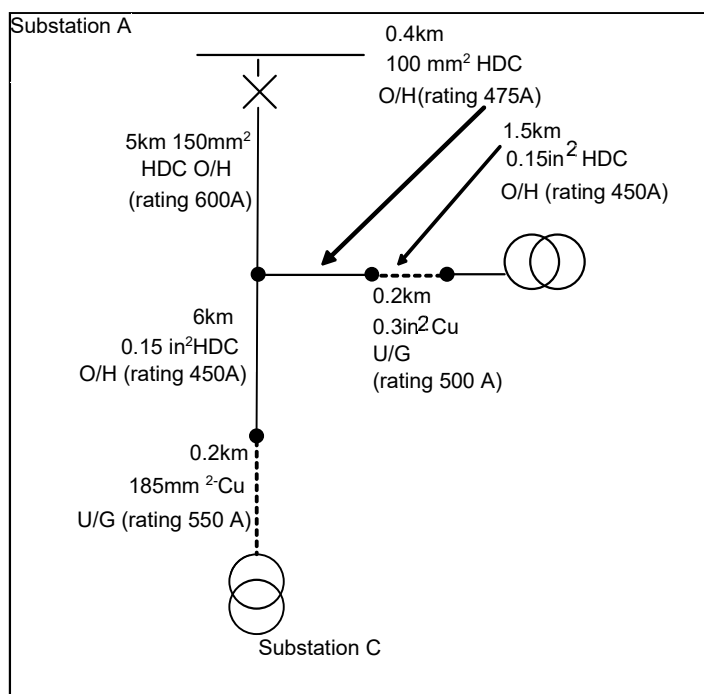
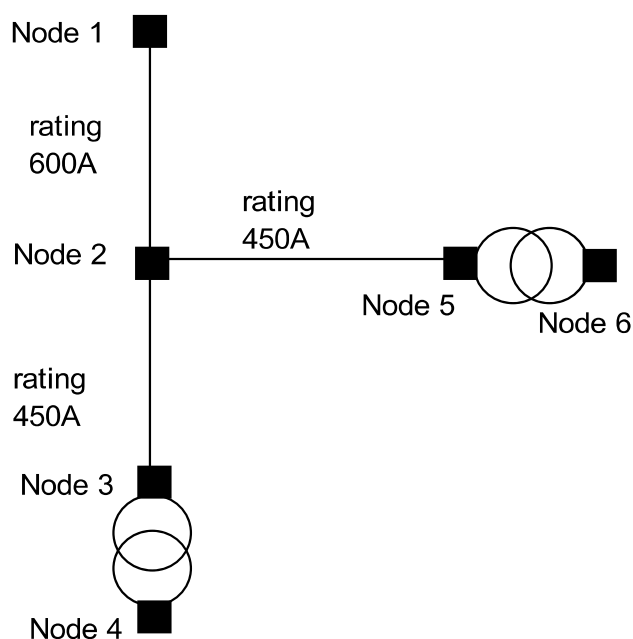

Figure 3 - The resultant Nodal model which represents the example network in Figure 2.**Table 4.9 - An example of the information held separately relating to Figure 2 which is used to provide the minimum composite branch rating.**

Branch	Line Section	Type	Length	Rating	R(p.u.) ¹⁸	X(p.u.)
Node 1 to Node 2	1	150mm ² HDC O/H	5km	600A	0.001	0.01
Node 2 to Node 3	1	0.15in ² HDC O/H	6km	450A	0.0018	0.0054
Node 2 to Node 3	2	185mm ² Cu U/G	0.2km	550A	0.00003	0.0003
Node 2 to Node 5	1	100mm ² HDC O/H	0.4km	475A	0.00004	0.0004
Node 2 to Node 5	2	0.3in ² Cu U/G	0.2km	500A	0.00003	0.0001
Node 2 to Node 5	3	0.15in ² HDC O/H	1.5km	450A	0.00045	0.00135

¹⁸ For the sake of simplicity ratings, resistance and reactance values given above are assumed and may be used only for illustrative purposes such as the given example to calculate equivalent ratings and parameters for a composite Branch.

Table 4.9A - Parameters used for the Nodal model shown in Figure 3.

Branch	Line Section	Rating	R(p.u.)	X(p.u.)
Node 1 to Node 2	1	600A	0.001	0.01
Node 2 to Node 3	1	450A	0.00183	0.0057
Node 2 to Node 5	3	450A	0.00052	0.00185

5. NETWORK DEMAND DATA

5.1 This section 5 describes the input data required to model the DNO Party's Distribution System for pricing purposes.

Demand Data (Load)

5.2 The load demands in the model will be the estimated demand for the year for which prices are being produced. This estimated demand will be based on actual recorded network data collected by the DNO Party. The following Demand Data is required as the basis of populating the Authorised Network Model:

- (a) Maximum Demands at each Connection Node;
- (b) Maximum Demands at Grid Supply Points;
- (c) Minimum Demands at Grid Supply Points; and
- (d) Maximum Demands at Bulk Supply Points or other intermediate substations (Only required if Method 1 or Method 3 Diversity calculations are being used).

5.3 The data will be based on the DNO Party's maximum load estimate for each substation as identified in the LTDS and represent the maximum load estimates at Grid Supply Point level as submitted by the DNO Party to the Independent System Operator and Planner for its Electricity Ten Year Statement (ETYS). Due to the timings difference between the publication of the Long Term Development Statement and the creation and publication of Use of System Charges the Demand Data may contain revised assumptions to the Long Term Development Statement. Where new EDCM Connectees

and substations are included in the Authorised Network Model, their demands will be individually assessed and estimated by the DNO Party.

- 5.4 The load estimates in the Long Term Development Statements, are normally cleansed and validated ensuring:
- (a) the maximum loads that are recorded reflect Normal Running Arrangements;
 - (b) consideration of application of suitable weather correction, if appropriate; and
 - (c) that latent demand is accounted for in accordance with the guidance contained in ETR130.

Demand Data (Generation)

- 5.5 Generation in the model will be based on the Maximum Export Capacities for EDCM Connectees. For the Minimum Demand Scenario a Generation Coincidence Factor will be applied, where appropriate. An F factor as described in ER P2/6 may be required for the Maximum Demand Scenario. Where sufficient actual recorded network data exists, a generator's site-specific F factor may be calculated, as described in ETR 130.

Modelling of Connectees with both Load and Generation

- 5.6 'Import/Export' Connectees (Connectees that have the ability to import electricity from, and export electricity to, the Distribution System) require special consideration so that only a single pair of Nodal marginal charges (Charge 1 and Charge 2) are calculated for each Connectee.
- 5.7 'Import/Export' Connectees are modelled as either a demand Connectee or a generation Connectee throughout both the Maximum Demand and Minimum Demand Scenarios - but not as both types of Connectees. The choice of model is based on whether the Connectee's dominant operating mode is that of a demand Connectee or a generation Connectee (determined by examination of the Connectee's Maximum Import Capacity and Maximum Export Capacity or kWh consumptions as appropriate). Thus, in both demand scenarios, the Connectee is treated solely as either a load Connectee or a generation Connectee according to their dominant behaviour.

- 5.8 In contrast, however, it may be noted that if two Connectees are connected to a single Node and one is a generation Connectee, the other a demand Connectee, then two sets of Nodal marginal charges would be produced - one for the demand, the other for the generation. This reflects the fact that the two individual Connectees can operate simultaneously in opposing modes, whereas this is clearly not possible for a single Import/Export Connectee.
- 5.9 Once the predominant operating mode has been determined for an Import/Export Connectee, the magnitudes of the demands to be applied in each scenario are determined by reference to the Network Demand Data (Load) and Demand Data (Generation) sections as appropriate.
- 5.10 The incremental costs for these Connectees are derived from increments applied with the appropriate power factor for the dominant behaviour of the Connectee (e.g. if the Connectee is considered to behave predominantly as a load Connectee, the power factor of the applied increment would be appropriate for a load i.e. 0.95).

Diversity Factors

- 5.11 The demands that are required to be populated in the Authorised Network Model need to be set so the modelled demand supplied through a GSP is equal to the Maximum Demand at the GSP as determined in the Network Demand Data (Load) section above. This may be achieved by using Diversity Factors to modify the Connection Node maximum demands or by the use of Negative Load Injections. The following describes acceptable methods to achieve this requirement.
- 5.12 To aid the description a simple network is shown in Figure 4 below which will provide a basis for the examples:

Figure 4 - Example model for the calculation of Diversity Factor.

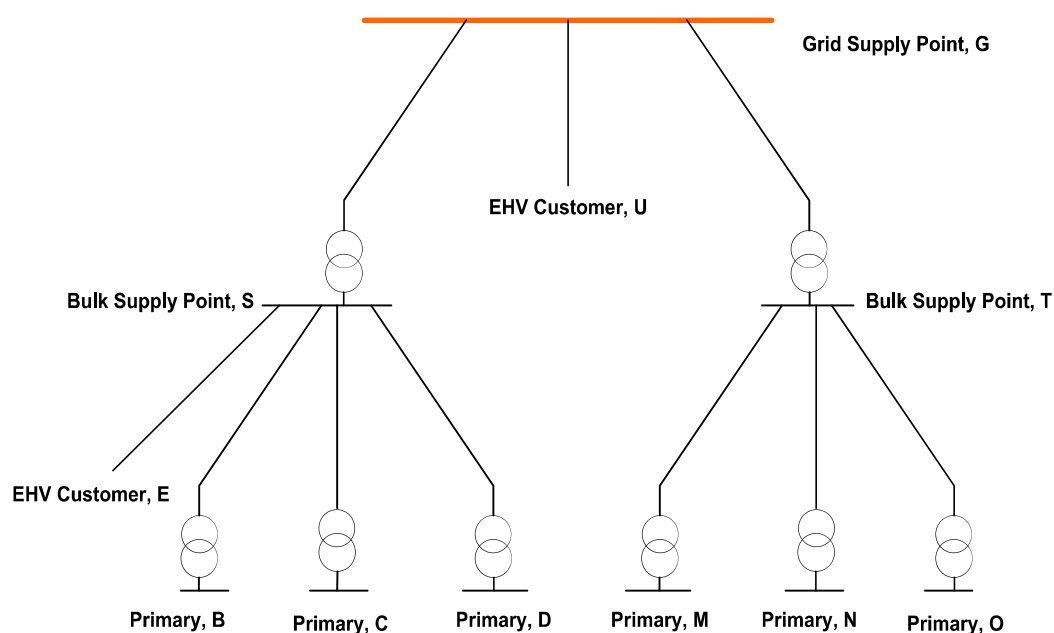

Method 1 – Hierarchical Diversity Factors

5.13 Networks are typically built as a hierarchy. The typical hierarchy levels are primary substation, Bulk Supply Points and Grid Supply Points. There may also be other intermediate levels such as 132kV switching substations. A Diversity Factor can then be calculated for each required substation. The Diversity Factor is calculated as the maximum demand at that substation divided by the sum of the maximum demands of all points of the network at the next lower hierarchy served by that substation plus an allowance for losses in that part of the network.

5.14 In our example, for Bulk Supply Point, S (see Figure 4), supplying three primary substations, B, C and D, and an EDCM Connectee E, Diversity Factor is derived as:

$$DF_S = MD_S / (MD_B + MD_C + MD_D + MD_E + losses_{S \rightarrow})$$

where MD_S is the maximum demand at substation S, MD_B is the Maximum Demand at substation B, MD_C is the Maximum Demand at substation C, MD_D is the Maximum Demand at substation D, MD_E is the Maximum Demand at the EDCM Connectee E substation, while $losses_{S \rightarrow}$ incurs line losses in the downstream network supplied from Bulk Supply Point S as shown in Figure 4.

- 5.15 Similarly for Grid Supply Point, G, supplying two Bulk Supply Points, S and T, and an EDCM Connectee U, Diversity Factor is derived as:

$$DF_G = MD_G / (MD_S + MD_T + MD_U + losses_{G \rightarrow})$$

- 5.16 Diversity Factors are calculated separately for each substation at each level. In our example Diversity Factors would be calculated for substations S, T, and G.
- 5.17 A Net Diversity Factor is then applied to each Connection Node based on the product of Diversity Factors of all the substations that supply that Connection Node. In the example the following Net Diversity Factors would be applied to each of the Connection Nodes.

Table 5.17 - Calculation of Net Diversity Factors - Hierarchical Diversity Factors.

Connection Node	Maximum Demand	Net Diversity Factor	Demand to be applied to the Network Model
Primary, B	MD_B	$DF_G * DF_S$	$DF_G * DF_S * MD_B$
Primary, C	MD_C	$DF_G * DF_S$	$DF_G * DF_S * MD_C$
Primary, D	MD_D	$DF_G * DF_S$	$DF_G * DF_S * MD_D$
EDCM Connectee, E	MD_E	$DF_G * DF_S$	$DF_G * DF_S * MD_E$
Primary, M	MD_M	$DF_G * DF_T$	$DF_G * DF_T * MD_M$
Primary, N	MD_N	$DF_G * DF_T$	$DF_G * DF_T * MD_N$
Primary, O	MD_O	$DF_G * DF_T$	$DF_G * DF_T * MD_O$
EDCM Connectee, U	MD_U	DF_G	$DF_G * MD_U$

- 5.18 Diversity Factors are applied to both the Active Power and Reactive Power demands at each connection point thus ensuring the power factor of the demand remains unchanged.

Method 2 – Single Diversity Factors

- 5.19 Where a network has significant interconnection or is subject to regular rearrangement (e.g. primary substations being transferred between Bulk Supply Points) the use of a

single Diversity Factor for all the demand supplied by a Grid Supply Point (or a set of interconnected Grid Supply Points) may be appropriate. The Diversity Factor for the GSP is calculated as the Maximum Demand at the GSP divided by the sum all the Maximum Demands of each Connection Node supplied from that GSP plus an allowance for losses.

- 5.20 Using the example shown in Figure 4 a single Diversity Factor for Grid Supply Point, G can be calculated as

$$DF_{G1} = MD_G / (MD_B + MD_C + MD_D + MD_E + MD_M + MD_N + MD_O + MD_U + losses)$$

where **losses** are network losses of the network shown in Figure 4.

- 5.21 The Net Diversity Factor in this method is equal to the calculated single Diversity Factor. In the example the following Net Diversity Factors would be applied to each of the Connection Nodes.

Table 5.21 - Calculation of Net Diversity Factors - Single Diversity Factors.

Demand point	Maximum Demand	Net Diversity Factor	Demand to be applied to the Network Model
Primary, B	MD_B	DF_{G1}	$DF_{G1} * MD_B$
Primary, C	MD_C	DF_{G1}	$DF_{G1} * MD_C$
Primary, D	MD_D	DF_{G1}	$DF_{G1} * MD_D$
EDCM Connectee, E	MD_E	DF_{G1}	$DF_{G1} * MD_E$
Primary, M	MD_M	DF_{G1}	$DF_{G1} * MD_M$
Primary, N	MD_N	DF_{G1}	$DF_{G1} * MD_N$
Primary, O	MD_O	DF_{G1}	$DF_{G1} * MD_O$
EDCM Connectee, U	MD_U	DF_{G1}	$DF_{G1} * MD_U$

- 5.22 Diversity Factors are applied to both the Active Power and Reactive Power demands at each connection point thus ensuring the power factor of the demand remains unchanged.

Method 3 – Negative Load Injections

- 5.23 A Negative Load Injection is a negative value of load calculated and applied to a source substation within the network model to represent the effects of diversity between associated downstream demands upon the actual demand observed at the source substation.
- 5.24 Negative Load Injections can be used to ensure that when the Maximum Demand is applied to each Connection Node then the modelled flow through the Grid Supply Point matches the Maximum Demand at the Grid Supply Point.
- 5.25 Negative Load Injections are applied at a substation to ensure that the demand at the substation equals the required Maximum Demand for that substation. Negative Load Injections are normally placed at Bulk Supply Points, other intermediate substations (such as 132kV switching Substation) and Grid Supply Points.
- 5.26 The amount of Negative Load Injection required to be applied at a substation is calculated as the maximum demand at that substation minus the sum of the maximum demands of all points of the network at the next lower hierarchy served by that substation plus an allowance for losses in that part of the network.
- 5.27 In our example, for Bulk Supply Point, S, supplying three Primary Substations, B, C and D, and an EDCM Connectee E, Negative Load Injection is derived as:

$$NLI_S = MD_S - (MD_B + MD_C + MD_D + MD_E + losses_{S \rightarrow})$$

- 5.28 Similarly for Grid Supply Point, G, supplying two Bulk Supply Points, S and T, and an EDCM Connectee U, Negative Load Injection is derived as

$$NLI_G = MD_G - (MD_S + MD_T + MD_U + losses_{G \rightarrow})$$

- 5.29 Note that the value of Negative Load Injection calculated is a negative number. This is modelled as a negative load (or generation) at the substation busbar so that the incoming flow matches the required maximum demand for that substation.
- 5.30 Negative Load Injections are applied as an Active Power injection only. No Reactive Power injection is applied.

Maximum Demand Data for the Authorised Network Model

Network Demand Data (Generation)

- 5.31 The Network Demand Data (Generation) element of the Maximum Demand Data will be constructed with generation output set at zero unless the generation can be considered to have a contribution to security of supply under ER P2/6, in which case the ER P2/6 level of export will be modelled.
- 5.32 The contribution of distributed generation to security of supply is dealt with in ER P2/6 through the application of F factors. Each Generation Installation is assigned an F factor and this represents the percentage of the generator's declared net capacity that can be considered when assessing network security. ER P2/6 also uses the term 'Persistence' to reduce the F factor for intermittent generation, as the time period (in hours) for which its contribution to security is being assessed increases. Table 2-4 of ER P2/6 recommends values of 'Persistence'; these values are dependent on the demand class being assessed. The value of 'Persistence' to be used for intermittent generation will be as stated in Table 2-4 of ER P2/6 for 'Other outage', using the maximum GSP (or GSP groups') demand instead of the demand class of the demand group.

Network Demand Data (Load)

- 5.33 The Network Demand Data (Load) element of the Maximum Demand Data will be constructed based on the Maximum Demands for each load point and either amended (Diversity Factors) or enhanced (Negative Load Injections) by the chosen diversity method (see section 5.11 (Diversity Factors) above).
- 5.34 The Diversity method is applied to the maximum demand load estimates for each load point to scale the modelled load in the Maximum Demand Data so that it reflects the Grid Supply Point maximum load estimates under Normal Running Arrangement.
- 5.35 The application of diversity in the derivation of this data needs to be carefully considered and aim to produce, where possible, within the constraints of a single set of Network Demand Data, power flows that reflect typical flows under the Maximum

Demand Scenario condition but also enable calculations to be undertaken upon an Authorised Network Model.

- 5.36 In considering the derivation of the Maximum Demand Data, it must be recognised that power flow analysis based on this Network Demand Data may not replicate the maximum power flow through individual assets that could be seen under all N-1 Contingency conditions, due to the limitations of analysis based upon a single set of Network Demand Data.

Minimum Demand Data for the Authorised Network Model

Network Demand Data (Generation)

- 5.37 The Network Demand Data (Generation) element of the Minimum Demand Data will be derived by application of a Generation Coincidence Factor to the Maximum Export Capacity of an Entry Point. There will be no adjustment for F factors.
- 5.38 Generation Coincidence Factors should be separately determined for each Grid Supply Point (or group of normally interconnected Grid Supply Points) using historic data. The Generation Coincidence Factor for each Grid Supply Point (or group of normally interconnected Grid Supply Points) will be applied to all generators, within the Authorised Network Model, that are supplied from the relevant Grid Supply Point (or group of normally interconnected Grid Supply Points).
- 5.39 The Generation Coincidence Factor for a Grid Supply Point (or group of Grid Supply Points) is equal to the maximum simultaneous MW generation output for all the EDCM (Generation) Connectees, within the Authorised Network Model, supplied from the Grid Supply Point (or group of Grid Supply Points), where suitable half hourly MW data is available, divided by the summated total of the Maximum Export Capacities of these generators.
- 5.40 Where Generation Coincidence Factors greater than 1 are determined for a Grid Supply Point (or group of normally interconnected Grid Supply Points), a Generation Coincidence Factor of 1 will be applied to all Generation Installations supplied from the relevant Grid Supply Point (or group of Grid Supply Points).

Network Demand Data (Load)

- 5.41 The Network Demand Data (Load) element of the Minimum Demand Data will be derived by application of a Scaling Factor to the Network Demand Data (Load) element of the Maximum Demand Data. Such Scaling Factors should be separately determined for each Grid Supply Point (or group of normally interconnected Grid Supply Points) using historic data. The Scaling Factors for each Grid Supply Point (or group of normally interconnected Grid Supply Points) will be applied to all loads taken from Exit Points supplied from the relevant Grid Supply Point (or group of normally interconnected Grid Supply Points).
- 5.42 The Scaling Factor for each Grid Supply Point (or group of normally interconnected Grid Supply Points) is calculated as:

$$\text{Scaling Factor}_G = \frac{\text{Minimum GSP Demand}_G}{\text{Maximum GSP Demand}_G}$$

Where:

Scaling Factor_G is the Scaling Factor for Grid Supply Point (or group of normally interconnected Grid Supply Points) G.

Maximum GSP Demand_G is the maximum demand at the Grid Supply Point (or group of normally interconnected Grid Supply Points) G as submitted by the DNO Party for inclusion in the Independent System Operator and Planner's Electricity Ten Year Statement (ETYS).

Minimum GSP Demand_G is the minimum demand at the Grid Supply Point (or group of normally interconnected Grid Supply Points) G validated and cleansed with the same criteria as that used for the **Maximum GSP Demand_G**.

6. POWER FLOW ANALYSIS PROCESS

- 6.1 This section 6 describes the power flow analysis undertaken for pricing purposes. The purpose of the load flow analysis is to determine the utilisation of the network under Normal Running Arrangement (Base Case Analysis) and N-1 Contingency condition (Contingency Analysis). Furthermore, this analysis assesses the effect of the change in the utilisation of the network caused by a change in demand (load and/or generation) at each Node. The Power Flow Analysis constitutes four main processes namely:
- (a) Base Case Analysis;
 - (b) Contingency Analysis;
 - (c) Security Factor calculation; and
 - (d) Incremented Flow analysis.
- 6.2 The processes are performed separately for the two different demand scenarios. The main difference between the two scenarios is the Network Demand Data that is used, although the Branch Rating may also be different. One demand scenario uses Maximum Demand Data and the other uses Minimum Demand Data with appropriate Branch Rating data. These processes and their main inputs and outputs are shown diagrammatically in Figure 5.

Figure 5 - Flowchart of the LRIC pricing model.

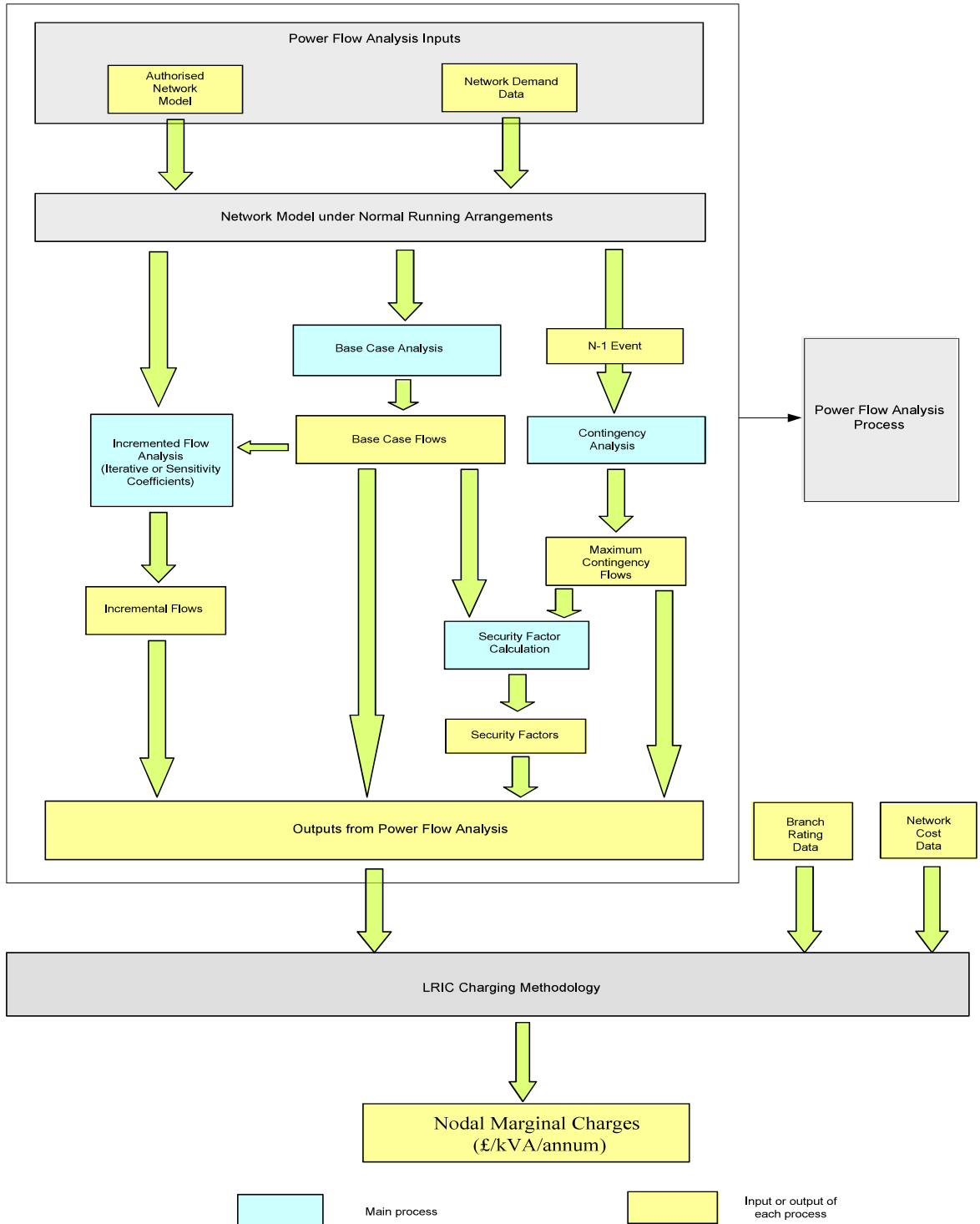

Base Case Analysis

6.3 The Base Case Analysis is required to determine the utilisation of the network under Normal Running Arrangements. The main inputs to the Base Case Analysis are the Authorised Network Model and Network Demand Data. The output of the Base Case Analysis is the Base Case Flow in each Branch of the Authorised Network Model. The steps in this Base Case Analysis are:

- (a) Step 1 - the Authorised Network Model is populated with the relevant Network Demand Data for the scenario (i.e. Maximum Demand Data or Minimum Demand Data); and
- (b) Step 2 - the Authorised Network Model is analysed under Normal Running Arrangements to determine the power flows across each of the network Branches and the results are referred to as Base Case Flows.

Contingency Analysis

6.4 Contingency Analysis is required to determine the utilisation of the network where the network assets provide security of supply under N-1 Contingencies, as defined by ER P2/6. This analysis evaluates the change in utilisation of network assets from Base Case Analysis.

6.5 The main inputs to the Contingency Analysis are the Authorised Network Model, the Network Demand Data and the N-1 Contingencies. Each N-1 Contingency will include the N-1 Event and the consequential network actions required to meet the security of supply requirements of ER P2/6. For example, where appropriate, it may include constraints in distributed generation output, automatic switching schemes, manual switching and customer demand reductions. The output of the Contingency Analysis is the Maximum Contingency Flow in each Branch of the Authorised Network Model. The steps in this Contingency analysis are:

- (a) Step 1 - the Authorised Network Model is populated with the relevant Network Demand Data for the scenario (i.e. Maximum Demand Data or Minimum Demand Data);

- (b) Step 2 - each N-1 Contingency is applied to the populated Authorised Network Model in turn and the resultant network is analysed to determine the power flows across each of the network Branches and the results are referred to as Contingency Flows; and
- (c) Step 3 - when Step 2 has been completed for all N-1 Contingencies in both network demand scenarios the maximum flow in each Branch across all the N-1 Contingency analyses is determined and the results are referred to as Maximum Contingency Flows.

Security Factor Calculation

- 6.6 Security Factors represent the change in utilisation of a Branch between Normal Running Arrangements and worst case N-1 Contingency conditions.
- 6.7 The main inputs to the Security Factor Calculation are the Base Case Flows and the Maximum Contingency Flows. The output of the Security Factor Calculation is a Security Factor for each Branch of the Authorised Network Model for each scenario (the Maximum Demand Scenario and the Minimum Demand Scenario).
- 6.8 A Security Factor for each Branch under each scenario (the Maximum Demand Scenario and the Minimum Demand Scenario) is calculated as:

$$Security\ Factor_b = \frac{Maximum\ Contingency\ Flow_b}{Base\ Case\ Flow_b}$$

Where:

Security Factor_b is the Security Factor for Branch b.

Maximum Contingency Flow_b is the Maximum Contingency Flow for Branch b as determined by Contingency Analysis.

Base Case Flow_b is the Base Case Flow for Branch b as determined by Base Case Analysis.

- 6.9 Where *Maximum Contingency Flow_b* is less than *Base Case Flow_b* then a Security Factor of 1 will be used for Branch b, reflecting that the highest utilisation occurs under Normal Running Arrangements.

Incremented Flow Analysis

- 6.10 The Incremented Flow analysis seeks to determine the change in power flows in the Authorised Network Model arising from the addition of a 0.1MW demand increment at a given Node. This analysis is repeated for each Node where incremental costs are required in the Authorised Network Model and for each network demand scenario. The demand increments are applied to the Authorised Network Model populated with the relevant Network Demand Data.
- 6.11 The power factor and direction of the demand increments applied to the Authorised Network Model depend upon the network demand scenario considered and also the type of demand that is located at the Node where the increments are applied. This is summarised in the following table:

Table 6.11 - Application of increments.

Increment Applied				
	Maximum Demand Scenario		Minimum Demand Scenario	
Type of Demand at Node Being Incremented	Power Factor	Direction	Power Factor	Direction
Demand (Load)	0.95	Load	0.95	Generation
Generation	Unity	Load	Unity	Generation

- 6.12 Increments applied at Nodes where demand (load) is located should be applied at 0.95 power factor under both the Maximum Demand Scenario and the Minimum Demand Scenario. In the Maximum Demand Scenario this increment should be applied in the direction of demand (load). In the Minimum Demand Scenario this increment should be applied in the direction of generation.
- 6.13 Increments applied at Nodes where generation is located should be applied at unity power factor under both scenarios. In the Maximum Demand Scenario this increment should be applied in the direction of demand (load). In the Minimum Demand Scenario this increment should be applied in the direction of generation.
- 6.14 Where both demand (load) and generation are located at a given Node, Incremented Flow analysis will be required to be performed once with increments at 0.95 power

factor at the Node and then again with separate application of increments at unity power factor at the Node.

- 6.15 The Incremented Flow analysis does not consider N-1 Contingencies. Security Factors derived from the Base Case Analysis and Contingency Analysis are used to determine the effect of N-1 Contingencies.
- 6.16 For each Node where increments are applied the difference between Incremented Flows and Base Case Flow need to be determined for each Branch. If the difference is greater than both 1kVA and 0.01% of the Branch Base Case Flow the Branch is further considered for the calculation of Nodal incremental costs. Power flow convergence criterion should be carefully selected to ensure that the power flow Nodal mismatches are smaller than the 1 kVA threshold.
- 6.17 The process is undertaken in Incremented Flow analysis for both the Maximum Demand Scenario and the Minimum Demand Scenario in turn. This is described below:
- (a) Step 1 - the Base Case Analysis is performed initially (see the Base Case Analysis section). The results of this analysis are Base Case Flows;
 - (b) Step 2 - the power flows across each of the network Branches are determined for the condition where the relevant increment (see Table 6.11) is applied to a Node. The results are referred to as Incremented Flows;
 - (c) Step 3 - the differences between the Incremented Flows and the Base Case Flows are evaluated. For those Branches where the difference is smaller than either 1kVA or 0.01% of the Base Case Flow then the Incremented Flow for that Branch is set to the Base Case Flow for that Branch; and
 - (d) Step 4 - steps 2 and 3 are repeated for each Node in turn until they have been completed for each Node in the Authorised Network Model.
- 6.18 The results of Incremented Flow analysis are collated with the other outputs of the power flow analysis (see Figure 5).

Calculation of Incremented Flows

- 6.19 Incremented Flows may be calculated either by:

- (a) application of the relevant increment to a Node in the Authorised Network Model and using load flow solution techniques to determine the power flow through each Branch (the Iterative Approach); or
 - (b) calculation of the power flow through each Branch, associated with the relevant increment to a Node, using sensitivity coefficients derived from the Base Case Analysis (the Sensitivity Coefficients Approach).
- 6.20 The method of calculation of the Incremented Flows should be selected such that the calculated Incremented Flows are a sufficiently accurate representation of the power flows arising from the addition of a 0.1MW demand increment at a Node. The method of calculation can be considered acceptable, where it is expected to produce Nodal incremental costs, derived from the Incremented Flows, that would vary by no greater than 5% from those that would be determined by use of the power flows arising from the addition of the demand increment.

Iterative Approach

- 6.21 The Iterative Approach determines the Incremented Flows required for the Incremented Flow analysis by applying the relevant single increment to each Node in turn to the Base Case and calculating the resultant Branch power flows using AC load flow solution techniques.
- 6.22 Prior to the application of the increment all the transformer tap positions, distributed generation outputs and switched shunt values are fixed to the values determined under Base Case Analysis to prevent change in their values when analysing the power flows with the increment applied.

Sensitivity Coefficients Approach

- 6.23 Sensitivity coefficients are a means of describing how the flow in a Branch of a network is affected by a small change of demand at a Node. There are two sensitivity coefficients for each Node-Branch combination namely:

- 6.23.1 Branch *ij* MVA power flow change with respect to a change of Active Power at the Node *n*, $\frac{\partial P_{ij}}{\partial P_n}$; and

6.23.2 Branch ij MVA power flow change with respect to a change of Reactive Power at a Node n , $\frac{\partial P_{ij}}{\partial Q_n}$.

- 6.24 Every Branch in the Authorised Network Model has a pair of coefficients (for real and reactive increments) for each Node on the network. Therefore, for a network with N Nodes and B Branches, there will be not more than $N*B$ sensitivity coefficients for real Nodal power increments and not more than $N*B$ sensitivity coefficients for reactive Nodal power increments.
- 6.25 This approach uses the standard output from the power flow analysis, i.e. for each Node n the following values: P_n P_i – active power injection at Node i , Q_i – reactive power injection at Node n , V_i - voltage magnitude at Node i and θ_n - θ_i – voltage angle at Node i . Then, for each Branch ij (between Node i and Node j) a set of sensitivity coefficients will be calculated using the set of equations here presented in matrix format (see matrix equation below):

$$A \cdot x = b; \text{ and therefore}$$

$$x = A^{-1} \cdot b$$

where x represents a vector of unknown sensitivity coefficients. A is the Jacobian Matrix which represent the first derivatives of active and reactive Nodal injections with respect to voltage angles and voltage magnitudes, respectively and b is the vector that shows the first derivatives of Branch power flow (MVA) with respect to Node voltage angles and magnitudes, respectively. It should be pointed that values of all derivatives in matrix A and vector b are calculated from the power flow solution obtained from Base Case Analysis. Sensitivity coefficients are calculated from the following equations:

$$\begin{bmatrix} \frac{\partial P_1}{\partial \theta_1} & \frac{\partial P_2}{\partial \theta_1} & \dots & \frac{\partial P_N}{\partial \theta_1} & \frac{\partial Q_1}{\partial \theta_1} & \frac{\partial Q_2}{\partial \theta_1} & \dots & \frac{\partial Q_N}{\partial \theta_1} \\ \frac{\partial P_1}{\partial \theta_2} & \frac{\partial P_2}{\partial \theta_2} & \dots & \frac{\partial P_N}{\partial \theta_2} & \frac{\partial Q_1}{\partial \theta_2} & \frac{\partial Q_2}{\partial \theta_2} & \dots & \frac{\partial Q_N}{\partial \theta_2} \\ \vdots & \vdots & \ddots & \vdots & \vdots & \vdots & \ddots & \vdots \\ \frac{\partial P_1}{\partial \theta_N} & \frac{\partial P_2}{\partial \theta_N} & \dots & \frac{\partial P_N}{\partial \theta_N} & \frac{\partial Q_1}{\partial \theta_N} & \frac{\partial Q_2}{\partial \theta_N} & \dots & \frac{\partial Q_N}{\partial \theta_N} \end{bmatrix} \times \begin{bmatrix} \frac{\partial P_{ij}}{\partial P_1} \\ \frac{\partial P_{ij}}{\partial P_2} \\ \vdots \\ \frac{\partial P_{ij}}{\partial P_N} \end{bmatrix} = \begin{bmatrix} \frac{\partial P_{ij}}{\partial \theta_1} \\ \frac{\partial P_{ij}}{\partial \theta_2} \\ \vdots \\ \frac{\partial P_{ij}}{\partial \theta_N} \end{bmatrix}$$

6.26

where:

i, j are the sending and receiving ends of Branch ij ;

N is the total number of Nodes;

$\frac{\partial P_N}{\partial V_N}$ $\frac{\partial Q_N}{\partial V_N}$ are the first derivatives of Active Power and Reactive Power injections at Node N with respect to a voltage magnitude change at Node N , respectively;

$\frac{\partial P_N}{\partial \theta_N}$ $\frac{\partial Q_N}{\partial \theta_N}$ are the first derivatives of Active Power and Reactive Power injections at Node N with respect to a change of voltage angle at Node N , respectively;

$\frac{\partial P_{ij}}{\partial P_N}$ $\frac{\partial P_{ij}}{\partial Q_N}$ are the sensitivity coefficients of Branch ij MVA power flow with respect to Active Power and Reactive Power injection at Node N , respectively; and

$\frac{\partial P_{ij}}{\partial \theta_N}$ $\frac{\partial P_{ij}}{\partial V_N}$ are the first derivatives of Branch ij MVA power flow with respect to voltage angle and magnitude at Node N , respectively.

6.27 All elements of matrix A and vector b can be calculated from the power flow analysis outputs and the electrical parameters of the Authorised Network Model. The system of equations presented above is of a generic nature. It should be noted that, in its practical application:

- (a) Slack Node – is used to balance the Distribution System (network) Active Power and Reactive Power. The corresponding rows related to Active Power and Reactive Power for this particular Node are omitted from the Jacobian matrix and consequently the corresponding sensitivities $\frac{\partial P_{ij}}{\partial P_n}$, $\frac{\partial P_{ij}}{\partial Q_n}$ are set to zero for this Node; and
- (b) PV Nodes – are used to maintain target voltages. This means that the voltage magnitude changes are omitted from the power flow state vector for such Nodes. The corresponding rows for Reactive Power are therefore omitted from the Jacobian matrix and consequently the corresponding sensitivities $\frac{\partial P_{ij}}{\partial Q_n}$ are set to zero for such Nodes.

6.28 For the calculation of Incremented Flows, sensitivity coefficients (vector x) are calculated from the power flow solution determined in the Base Case Analysis. Once calculated, the sensitivity coefficients are used to calculate the new power flow in a Branch by multiplying the coefficient by the Nodal increment or decrement to evaluate the change in power flows and adding this to the Base Case Flow of the Branch. The results are referred as Incremented Flows.

6.29 For an increment of 0.1 MW at 0.95 power factor (i.e. 0.1 MW and 0.0329 MVar):

$$\text{Incremented Flow}_{n,ij} = \text{Base Case Flow}_{ij} + 0.1 * \frac{\partial P_{ij}}{\partial P_n} + 0.0329 * \frac{\partial P_{ij}}{\partial Q_n}$$

where, $\text{Incremented Flow}_{n,ij}$ is the new MVA power flow in Branch ij as a result of a change of demand at Node n , $\text{Base Case Flow}_{ij}$ is the MVA power flow in Branch ij as determined in the Base Case Analysis, $\frac{\partial P_{ij}}{\partial P_n}$ is the Active Power sensitivity coefficient for a Node n and Branch ij combination; and $\frac{\partial P_{ij}}{\partial Q_n}$ is the Reactive Power sensitivity coefficient for a Node n and Branch ij combination.

Outputs from Power Flow Analysis

6.30 To illustrate the outputs from the power flow analysis the example network is shown in Figure 6 and the power flow analysis results (from the application of 0.1MW increments, in the direction of demand (load), to Nodes in the Maximum Demand Scenario) is shown in Table 6.32.

Figure 6 - Example network.

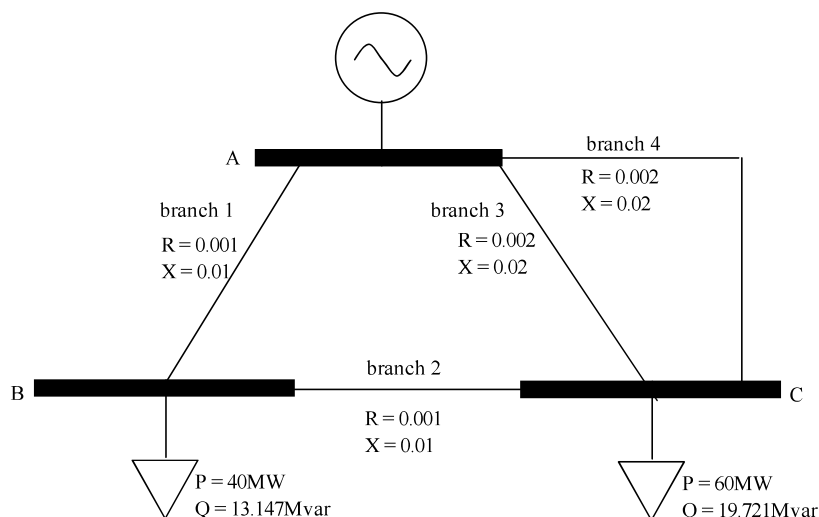

6.31 Table 6.32 shows the Base Case Flow, Contingency Flow, Incremented Flow, the power factor of the applied demand increment and the Security Factor for each Branch per Node for Maximum Demand Scenarios.

6.32 Similar tables would need to be created for the following scenarios/increments:

- Minimum Demand Scenario – applying 0.1 MW at 0.95 power factor in generation direction at each Node where demand is located;
- Maximum Demand Scenario - applying 0.1 MW at unity power factor in demand direction at each Node where generation is located; and
- Minimum Demand Scenario – applying 0.1 MW at unity power factor in generation direction at each Node where generation is located.

Table 6.32 - An example set of output results from Maximum Demand Scenario

Node where increments are applied	Power Factor Of Demand Increment	Branch	Base Case Flow (MVA)	Maximum Contingency Flow(MVA)	Security Factor	Incremented Flow(MVA)
			A	B	=B/A	
B	0.95	Branch 1	49.228	63.356	1.287	49.299
		Branch 2	7.024	42.179	6.005	6.989
		Branch 3	28.133	52.890	1.880	28.151
		Branch 4	28.133	52.890	1.880	28.151
C	0.95	Branch 1	49.228	63.356	1.287	49.263
		Branch 2	7.024	42.179	6.005	7.059
		Branch 3	28.133	52.890	1.880	28.168
		Branch 4	28.133	52.890	1.880	28.168

6.33 It should be noted that, where both demand (load) and generation are located at a given Node, two sets of results will be produced at the Node for each scenario (one set for application of increments at 0.95 power factor and another for increments applied at unity power factor).

6.34 For each Node where demand is incremented any Branch showing a power flow change greater than both 1kVA and 0.01% of the Branch Base Case Flow is listed in table 6.32 above, which also shows the Base Case Flow, Security Factor and Incremented Flow. The filtering of the flows against the above criteria may be carried out at this stage of the power flow analysis or alternatively included in the cost modelling element of the process for pricing. It should be noted that for each Node-Branch combination the Base Case Flows, Security Factors, Incremented Flows and Branch Ratings may be different.

7. CALCULATION OF NODAL INCREMENTAL COSTS

7.1 The calculation of Nodal incremental costs is based on the outputs obtained from the power flow analysis process (see Figure 5 in section 6, Power flow analysis process).

- 7.2 Using the results of the power flow analysis, Branch Rating data and reinforcement costs, the Nodal marginal charges can be calculated based on the procedure discussed in section 8 (Output results) below.
- 7.3 The main principles for the calculation of reinforcement costs are given in section 7.4 (Reinforcement Cost Calculation Principles) below, while the Branch Rating data is discussed in section 7.5 (Branch Rating Data) below.

Reinforcement Cost Calculation Principles

- 7.4 These are general principles for the calculation of the reinforcement costs:
- (a) each Branch within the Authorised Network Model should be considered as being one of three types:
 - (i) Transformer Branches - which represent Branches at substations that provide transformation between different voltage levels;
 - (ii) Circuit Branches - which represent an interconnection (or part of an interconnection) between substations and which operate at a single voltage level; or
 - (iii) Zero-cost Branches - these Branches exist in the network model but have zero reinforcement costs;
 - (b) Zero-cost Branches will include, but not be limited to:
 - (i) Branches that represent assets that are not part of the DNO Party's Distribution System for which incremental costs are being calculated (e.g. sections of the National Electricity Transmission System, adjacent Distribution Systems etc.);
 - (ii) Branches that represent Sole Use Assets; and
 - (iii) Branches that represent internal connections within substations, other than installed transformation (e.g. bus couplers, bus section circuit breakers etc.);

a cost of reinforcement will be allocated to each Transformer Branch and Circuit Branch taking account where possible of:

- (c) the voltage of operation of the Circuit (or in the case of Transformer Branches, the voltages of transformation);
 - (i) the existing mix of overhead line and underground cable within Circuit Branches; and
 - (ii) the requirements and costs of similar historic reinforcement projects.
 - (iii) the cost of reinforcement for a Branch will be constructed from typical unit costs appropriate to the categorisation of the Branch and the components represented.
- (d) the costs associated with substation plant and equipment (such as circuit breakers, switches, protection equipment, earthing devices etc.) will be included within the cost of reinforcement and allocated appropriately across the Transformer Branches and Circuit Branches to which they relate; and the typical unit costs used to derive the cost of reinforcement for a Branch will:
 - (i) reflect the modern equivalent asset value of reinforcing the particular asset;
 - (ii) include overheads directly related to the construction activity; and
 - (iii) include building and civil engineering works, in unmade ground.

Branch Rating Data

7.5 Each Branch in the Authorised Network Model needs to be assigned a Branch Rating appropriate to each analysis scenario considered. Where a Branch represents a number of components (for instance, a number of sections of overhead line and/or underground cable) then the rating of that Branch is calculated by looking at the ratings of all the

subcomponents and determining the lowest value. The rating of a transformer will be the capability of the transformer to supply load at its secondary terminals.

8. OUTPUT RESULTS

Basis of calculation of Peak and Off-Peak Nodal marginal charges

- 8.1 The outputs of the power flow analysis discussed in section 6 (**Power flow analysis process**) above, and the Branch Ratings and the reinforcement costs discussed in section 7 (**Calculation of Nodal incremental costs**) are further used to calculate Nodal marginal charges. The main outputs of this process (shown as the LRIC Charging Methodology block in Figure 5) are Nodal marginal charges in £/kVA/annum for Maximum Demand (Peak Charge) and Minimum Demand Scenario (Off-Peak Charge).
- 8.2 These are the main characteristics of the calculation of Nodal marginal Peak and Off-Peak Charges:
- (a) For each Node where either demand or generation is located, Peak and Off-Peak Charges (a single pair of charges for the Node) are calculated using data from the analysis of the Maximum Demand Scenario and Minimum Demand Scenario, respectively. If both generation and demand are located at the same Node a pair of Peak/Off-Peak Charges is produced for each of them (a double pair of charges for the Node).
 - (b) The first step in the calculation of Peak and Off-Peak Charges is the calculation of Branch incremental costs (ΔC_i) for each of two demand scenarios (ΔC_i^{peak} and $\Delta C_i^{off-peak}$) and for each applied increment. The formulae that should be used to calculate Branch incremental costs (ΔC_i) are given in Attachment 1 below.
 - (c) Branch incremental costs (ΔC_i) could be either positive or negative. For example, if the applied increment at a Node causes larger incremented flows (MVA) than the Base Case Flows ($IncPowerFlow(MVA) > BasePowerFlow(MVA)$, see Attachment 1 below), $YearsToReinforcement(inc)$ would be smaller than $YearsToReinforcement(base)$ and consequently ΔC_i would be a

positive value. The calculation of these times to reinforcement is described on a simple network example in Attachment 2 below.

- (d) Reinforcement of a Branch can be driven by either the Maximum Demand or the Minimum Demand Scenario. The period that is deemed to drive reinforcement, for each individual Branch, identified by application of increments at a given Node, is the period with the highest absolute value of associated Branch incremental cost. To decide which scenario drives the Branch reinforcement, in each case, the corresponding absolute values of the Branch incremental costs should be compared.

Sense Checking Of Branch Incremental Costs

- 8.3 The overall recovery of charges (*PositiveCostRecovery*) for each Branch is individually examined and checked against the actual reinforcement cost for the Branch (*ActualReinforcementCost*) in order to assess whether the charge recovery for the Branch is excessive. Where excessive charge recovery in a Branch is identified a Positive Recovery Factor is applied to limit the recovery of charges in the Branch to the actual reinforcement cost.
- 8.4 The overall recovery of credits (*NegativeCostRecovery*) for each Branch is individually examined and checked against the actual reinforcement cost for the Branch (*ActualReinforcementCost*) in order to assess whether the recovery of credits for the Branch is excessive. Where excessive credit recovery in a Branch is identified a Negative Recovery Factor is applied to limit the total recovered credits to the actual reinforcement cost. The cost recovery in a particular Branch, associated with application of an increment at a Node where demand (load) is located, is:
- (a) the product of the Branch incremental cost, divided by the load increment, and the modelled load at the Node used in the Network Demand Data (Load) that represents the Maximum Demand Scenario - where the period that drives reinforcement is the Maximum Demand Scenario; or
 - (b) the product of the negative of the Branch incremental cost, divided by the load increment, and the modelled load at the Node used in the Network Demand Data (Load) that represents the Minimum Demand Scenario -

where the period that drives reinforcement is the Minimum Demand Scenario.

8.5 The cost recovery in a particular Branch, associated with application of an increment at a Node where generation is located, is:

- (a) the product of the negative of the Branch incremental cost, divided by the generation increment, and the modelled generation output at the Node used in the Network Demand Data (Generation) that represents the Maximum Demand Scenario - where the period that drives reinforcement is the Maximum Demand Scenario; or
- (b) the product of the Branch incremental cost, divided by the generation increment, and the modelled generation output at the Node used in the Network Demand Data (Generation) that represents the Minimum Demand Scenario - where the period that drives reinforcement is the Minimum Demand Scenario.

8.6 The positive cost recovery for a Branch is the summation of the cost recovery for the particular Branch across all Nodes where the Node's contribution is positive. This is expressed mathematically below:-

$$PositiveCostRecovery_i =$$

$$\left| \left(\sum_{k, \Delta C_i^k < 0} (-\Delta C_i^k) \cdot G_k^{peak} + \sum_{l, \Delta C_i^l > 0} (\Delta C_i^l) \cdot G_l^{off-peak} \right) / 100 + \left(\sum_{m, \Delta C_i^m > 0} (\Delta C_i^m) \cdot L_m^{peak} + \sum_{n, \Delta C_i^n < 0} (-\Delta C_i^n) \cdot L_n^{off-peak} \right) / 105.26 \right|$$

Where:

PositiveCostRecovery_i is the annual recovered 'positive' costs (i.e. charge) for Branch *i*,

k denotes Nodes where generation is located that produce Branch incremental costs for Branch *i*, where the period that drives reinforcement is the period represented by the Maximum Demand Scenario,

ΔC^k_i is the Branch incremental cost (£/annum) for Branch *i*, for generation Node "k" in the period represented by the Maximum Demand Scenario,

G^{peak}_k is the generator output (kVA) at Node “k” in the Network Demand Data (Generation) representing the Maximum Demand Scenario,

l denotes Nodes where generation is located that produce Branch incremental costs for Branch i , where the period that drives reinforcement is the period represented by the Minimum Demand Scenario,

ΔC^l_i is the Branch incremental cost (£/annum) for Branch i , for generation Node “l” in the period represented by the Minimum Demand Scenario,

$G^{off-peak}_l$ is the generator output (kVA) at Node “l” in the Network Demand Data (Generation) representing the Minimum Demand Scenario,

m denotes Nodes where demand (load) is located that produce Branch incremental costs for Branch i , where the period that drives reinforcement is the period represented by the Maximum Demand Scenario,

ΔC^m_i is the Branch incremental cost (£/annum) for Branch i , for generation Node “m” in the period represented by the Maximum Demand Scenario,

L^{peak}_m is the load (kVA) at Node “m” in the Network Demand Data (Load) representing the Maximum Demand Scenario,

n denotes Nodes where demand (load) is located that produce Branch incremental costs for Branch i , where the period that drives reinforcement is the period represented by the Minimum Demand Scenario,

ΔC^n_i is the Branch incremental cost (£/annum) for Branch i , for generation Node “n” in the period represented by the Minimum Demand Scenario,

$L^{off-peak}_n$ is the load (kVA) at Node “n” in the Network Demand Data (Load) representing the Maximum Demand Scenario load.

8.7 The negative cost recovery for a Branch is the summation of the cost recovery for the particular Branch across all Nodes where the Node’s contribution is negative. This is expressed mathematically below:-

$$NegativeCostRecovery_i =$$

$$\left| \left(\sum_{k, \Delta C_i^k > 0} (-\Delta C_i^k) \cdot G_k^{peak} + \sum_{l, \Delta C_i^l < 0} (\Delta C_i^l) \cdot G_l^{off-peak} \right) / 100 + \left(\sum_{m, \Delta C_i^m < 0} (\Delta C_i^m) \cdot L_m^{peak} + \sum_{n, \Delta C_i^n > 0} (-\Delta C_i^n) \cdot L_n^{off-peak} \right) / 105.26 \right|$$

where:

NegativeCostRecovery_i is the annual recovered ‘negative’ costs (i.e. credit). Each £/annum figure is negative and the absolute value of the total cost recovery is calculated. All quantities are defined in the paragraph above.

8.8 The actual reinforcement cost of a Branch is determined by:-

$$ActualReinforcementCost_i = AnnuityRate \cdot CostOfReinforcementSolution_i$$

Where:

ActualReinforcementCost_i is the annuitised reinforcement cost for Branch *I*;

AnnuityRate is the annuity rate used in the calculation of Branch incremental costs, as described in Attachment 1 below; and

CostOfReinforcementSolution_i is the reinforcement cost for Branch *i*, as used in the calculation of the Branch incremental cost.

8.9 A Positive Recovery Factor is determined for each Branch, as follows:

- (a) if *PositiveCostRecovery_i* is greater than *ActualReinforcementCost_i* for Branch *i*, the Positive Recovery Factor, s_{P_i} , is given by:

$$s_{P_i} = ActualReinforcementCost_i / PositiveCostRecovery_i$$

- (b) otherwise:

$$s_{P_i} = 1$$

8.10 A Negative Recovery Factor is calculated for each Branch in the following way:

- (a) if *NegativeCostRecovery_i* is greater than *ActualReinforcementCost_i* for Branch *i*, the Negative Recovery Factor, s_{N_i} , is given by:

$$s_{N_i} = ActualReinforcementCost_i / NegativeCostRecovery_i$$

- (b) otherwise:

$$s_{Ni} = 1$$

8.11 Two Recovery Factors are determined for each Branch. The Positive Recovery Factor for a particular Branch is applied to all positive Branch incremental costs associated with that Branch, when calculating Nodal incremental costs, irrespective of the period to which the Branch incremental costs relate. Similarly, the Negative Recovery Factor for a particular Branch is applied to all negative Branch incremental costs associated with that Branch, when Nodal incremental costs are calculated.

Demand Nodes

8.12 For Nodes where demand (load) is located:

- (a) Table 8.12 describes the comparison performed for Branch reinforcements identified by application of increments to a Node where demand (load) is located.
- (b) For the Maximum Demand Scenario the increment is applied in the demand (load) direction. If such an increase in demand (load) accelerates the reinforcement ($\Delta C_i^{peak} > 0$) the demand should be charged (Table 8.12, the first row, column 'Credit/Charge'). For the Minimum Demand Scenario the increment is applied in the generation direction (a reduction of demand). If such reduction of demand (load) would accelerate the reinforcement ($\Delta C_i^{off-peak} > 0$) then the demand charge takes the form of a credit (Table 8.12 the third row, column 'Credit/Charge').
- (c) It should be pointed out that each Branch incremental cost is considered in just one out of two charge periods (Peak or Off-Peak but not both) based on the scenario that drives the maximum absolute value of Branch incremental cost, as shown in Table 8.12. A calculation of Nodal incremental costs and Nodal marginal charges for a simple network example is given in Attachment 2 below.
- (d) To calculate the Peak Nodal incremental cost, a sum of all peak incremental costs ΔC_i^{peak} , each scaled by the appropriate Recovery Factor s_i , over all

Branches where the Maximum Demand scenario drives reinforcements, associated with the application of an increment at the Node, should be determined. To calculate the Off-Peak Nodal incremental cost a sum of all off-peak incremental costs $\Delta C_i^{off-peak}$, each scaled by the appropriate Recovery Factor S_i , over all Branches where the Minimum Demand scenario drives the reinforcements, associated with the application of an increment at the Node, should be determined.

- (e) To calculate the £/kVA/annum Peak and Off-Peak Nodal marginal charges the obtained sums should be divided by the corresponding kVA increment (using 0.1 MW at 0.95 power factor). A calculation of Nodal incremental costs and Nodal marginal charges for a simple network example is given in Attachment 2 below.
- (f) The Peak and Off-Peak Nodal marginal charges are the main output results that will be used for the calculation of the total Use of System Charges. The other outputs are discussed in Attachment 3 below.
- (g) The adopted sign convention with respect to Peak Charges and Off-Peak Charges (output values) is given in the last column of Table 8.12. It should be noted that the convention follows the sign of ΔC_i .

Table 8.12 - Scenarios that drive reinforcement and the rules for the calculation of Branch reinforcement charges/credits for a demand (load) located at a Node.

Increment Direction	Branch incremental cost comparison	Reinforcement cost scenario assigned to the Branch	Sign of ΔC_i	Accelerate / Delay Reinforcement	Charge /Credit £/kVA/ annum	Output Convention
Demand Increase	$abs(\Delta C_i^{peak}) > abs(\Delta C_i^{off-peak})$	Maximum Demand (Peak)	$\Delta C_i^{peak} > 0$	Accelerate	Peak Charge	Positive
Demand Increase	$abs(\Delta C_i^{peak}) > abs(\Delta C_i^{off-peak})$	Maximum Demand (Peak)	$\Delta C_i^{peak} < 0$	Delay	Peak Credit	Negative
Demand Reduction	$abs(\Delta C_i^{peak}) < abs(\Delta C_i^{off-peak})$	Minimum Demand (Off-Peak)	$\Delta C_i^{off-peak} > 0$	Accelerate	Off-Peak Credit	Positive
Demand Reduction	$abs(\Delta C_i^{peak}) < abs(\Delta C_i^{off-peak})$	Minimum Demand (Off-Peak)	$\Delta C_i^{off-peak} < 0$	Delay	Off-Peak Charge	Negative

Generation Nodes

8.13 For Nodes where generation is located:

- (a) To decide which scenario drives the Branch reinforcement for a Node where a generator is located Table 8.13 should be used.
- (b) For the Maximum Demand Scenario the increment is applied in the demand direction (a reduction of generation). If such reduction of generation delays the reinforcement ($\Delta C_i^{peak} < 0$) the generator should be charged (the second row, column 'Credit/Charge'). For the Minimum Demand Scenario the increment is applied in the generation direction (an increase in generation). If such increase in generation delays the reinforcement ($\Delta C_i^{off-peak} < 0$) the generator should be credited (the fourth row, column 'Credit/Charge').
- (c) It should be pointed out that each Branch incremental cost is included in one of two charge periods (Peak or Off-Peak but not both) based on the scenario that drives the maximum absolute value of Branch incremental cost as shown in Table 8.13.
- (d) To calculate the Peak Nodal incremental cost a sum of Peak incremental cost ΔC_i^{peak} , each scaled by the appropriate Recovery Factor S_i , over all Branches where the Maximum Demand scenario drives reinforcements, associated with the application of an increment at the Node, should be determined. To calculate the Off-Peak Nodal incremental cost a sum of off-peak incremental cost $\Delta C_i^{off-peak}$, each scaled by the appropriate Recovery Factor S_i , over all Branches where the Minimum Demand scenario drives the reinforcement, associated with the application of an increment at the Node, should be determined.
- (e) To calculate the £/kVA/annum Peak Off-Peak Nodal marginal charges the obtained sums should be divided by the corresponding kVA increment (using 0.1 MW at unity power factor). The last column given in Table 8.13 indicates the sign convention adopted for the output values. It should be noted that the convention follows the sign of ΔC_i .

Table 8.13 - Scenarios that drive reinforcement and the rules for the calculation of Branch reinforcement charges/credits for a generation located at a Node.

Increment Direction	Branch incremental cost comparison	Reinforcement cost scenario assigned to the Branch	Sign of ΔC_i	Accelerate / Delay Reinforcement	Charge /Credit £/kVA/ annum	Output Convention
Generation Reduction	$abs(\Delta C_i^{peak}) > abs(\Delta C_i^{off-peak})$	Maximum Demand (Peak)	$\Delta C_i^{peak} > 0$	Accelerate	Peak Credit	Positive
Generation Reduction	$abs(\Delta C_i^{peak}) > abs(\Delta C_i^{off-peak})$	Maximum Demand (Peak)	$\Delta C_i^{peak} < 0$	Delay	Peak Charge	Negative
Generation Increase	$abs(\Delta C_i^{peak}) < abs(\Delta C_i^{off-peak})$	Minimum Demand (Off-Peak)	$\Delta C_i^{off-peak} > 0$	Accelerate	Off-Peak Charge	Positive
Generation Increase	$abs(\Delta C_i^{peak}) < abs(\Delta C_i^{off-peak})$	Minimum Demand (Off-Peak)	$\Delta C_i^{off-peak} < 0$	Delay	Off-Peak Credit	Negative

Decomposition of Nodal Incremental Costs

8.14 Each charge at a Node is decomposed into two sub-elements, termed ‘local’ and ‘remote’ such that:

$$ChargeAtNode^{Peak} = LocalChargeAtNode^{Peak} + RemoteChargeAtNode^{Peak}$$

$$ChargeAtNode^{Off-Peak} = LocalChargeAtNode^{Off-Peak} + RemoteChargeAtNode^{Off-Peak}$$

8.15 These sub-elements use the voltage of each Branch as a proxy to determine whether a particular Branch incremental cost should be regarded as an incremental cost associated with an asset close to the Node where the increment was applied, or whether incremental cost should be regarded as being associated with an asset that is remote from the Node.

8.16 The local element of each Nodal incremental cost is derived by summing the Branch incremental costs associated with:

- (a) Branches that are operating at the same nominal voltage as the voltage of the Node where the increment was applied; and
- (b) Branches that represent, transformation from a higher voltage down to the same nominal voltage as the voltage of the Node where the increment was applied.

- 8.17 The remote element of each Nodal incremental cost is derived from the Branch incremental costs from all Branches other than those where the Branches are operating at the same nominal voltage as the voltage of the Node where the increment was applied, or where the Branches represent transformation from a higher voltage down to the same nominal voltage as the Node where the increment was applied. In other words, all Branches that are not ‘local’ are ‘remote’.

Individual Connectees Connected To Multiple Nodes

- 8.18 Where individual Connectees are connected to more than one Node within the Authorised Network Model (for example sites with multiple Exit Points or Entry Points) they should be considered as a single entity in the calculation of final Use of System Charges. Such Connectees are treated as being connected to a ‘Hybrid Customer’ Node.
- 8.19 ‘Hybrid Customer’ Nodes will, for either Demand (load) or Demand (generation) as appropriate for each individual Connectee:
- (a) combine the (Charge 1) charges associated with each of the Nodes through the use of a weighted average based on the proportion of the Connectee’s demand observed at each of the Nodes in the Maximum Demand Scenario, under Normal Running Arrangements;
 - (b) combine the (Charge 2) charges associated with each of the Nodes through the use of a weighted average based on the proportion of the Connectee’s demand observed at each of the Nodes in the Minimum Demand Scenario, under Normal Running Arrangements; and
 - (c) aggregate Active Power and Reactive Power data for either Demand (Load) or Demand (Generation) as appropriate, relating to all relevant Nodes (Items 5 to 8 of in Table 14 Attachment 2 below).
- 8.20 Where ‘Hybrid Customer’ Nodes are created, the Active Power and Reactive Power data in the output information for each of the Nodes to which the Connectee is connected will be set to zero so as not to double-count the aggregate demand data stated at the ‘Hybrid Customer’ Node.

- 8.21 An example of the creation of a 'Hybrid Customer' Node is given below for a single Demand (load) Connectee connected to two Nodes, designated Node A and Node B. The 'Hybrid Customer' Node, representing this Connectee, would have the following output data:

Charge 1 hybrid =

$$((Chrg1A \times MaxDemA) + (Chrg1B \times MaxDemB)) / (MaxDemA + MaxDemB)$$

Charge 2 hybrid =

$$((Chrg2A \times MinDemA) + (Chrg2B \times MinDemB)) / (MinDemA + MinDemB)$$

Max. demand data hybrid = $MaxDemA + MaxDemB$

Min. demand data hybrid = $MinDemA + MinDemB$

Where

Chrg1A = Charge 1 value (corresponding to the Maximum Demand Scenario) at Node A

Chrg2A = Charge 2 value (corresponding to the Minimum Demand Scenario) at Node A

MaxDemA = the demand in the Maximum Demand Scenario at Node A

MinDemA = the demand in the Minimum Demand Scenario at Node A

and equivalent terms are defined for Node B.

Attachment 1 - Calculation of Branch Incremental Cost

1. Branch incremental cost ΔC_i is calculated using the outputs of power flow analysis discussed in the Outputs from Power Flow Analysis section and the following formulae for both Maximum and Minimum Demand Scenario:

$$\Delta C_i = [NetPresentValue(inc) - NetPresentValue(base)]AnnuityRate$$

$$NetPresentValue(inc) = \frac{CostOfReinforcementSolution}{[1 + DiscountRate]^{YearsToReinforcement(inc)}}$$

$$NetPresentValue(base) = \frac{CostOfReinforcementSolution}{[1 + DiscountRate]^{YearsToReinforcement(base)}}$$

CostofReinforcementSolution is the modern equivalent asset value (MEAV) of reinforcing the particular asset, bearing in mind the requirements of similar historic projects¹⁹. This cost is the same under both base and incremental conditions and it should be annualised using the following annuity rate:

$$AnnuityRate = \frac{DiscountRate}{1 - \left[\frac{1}{[1 + DiscountRate]^{AnnuityPeriod}} \right]}$$

DiscountRate is set to equal the latest pre-tax real weighted average cost of capital (CC below) for each DNO Party calculated using the following formula:

$$CC = (Gearing\ Assumption \times Pre\text{-}Tax\ Cost\ of\ Debt) + (1 - Gearing\ Assumption) * (Post\ Tax\ Cost\ of\ Equity / (1 - Corporation\ Tax\ Rate))$$

where:

Gearing Assumption is set to the 'Notional gearing' value for the regulatory year for which tariffs are being set in the latest version of the PCFM (InputSummary sheet, Finance inputs, Vanilla allowed return on capital) prepared for the relevant DNO Party for publication with such tariff setting on the DNO Party's website;

¹⁹ Distributors should use the specifications and costs of similar, past reinforcement projects as a means for determining the requirements and costs of a particular future reinforcement project.

Pre-Tax Cost of Debt is set to the ‘Allowed return on debt’ value for the regulatory year for which tariffs are being set in the latest version of the PCFM (InputSummary sheet, Finance inputs, CAPM calculator tool: allowed return on debt) prepared for the relevant DNO Party for publication with such tariff setting on the DNO Party’s website;

Post Tax Cost of Equity is set to the ‘Allowed return on equity’ value for the regulatory year for which tariffs are being set in the latest version of the PCFM (InputSummary sheet, Finance inputs, CAPM calculator tool: allowed return on equity) prepared for the relevant DNO Party for publication with such tariff setting on the DNO Party’s website; and

Corporation Tax Rate is set to the ‘Corporation tax rate’ value for the regulatory year for which tariffs are being set in the latest version of the PCFM (InputSummary sheet, Tax, Tax policy) prepared for the relevant DNO Party for publication with such tariff setting on the DNO Party’s website.

In the event of any value not being available from the above data sources, the DNO Party will prepare a forecast of the value to be used in the CC formula instead.

The CC value is calculated as a percentage, and rounded to two decimal places.

AnnuityPeriod is the period over which costs are annualised. This period is set to 40 years and represents the typical life of an asset.

2. Power flows and Branch capacities calculated by the power flow analysis under base and incremental conditions are fed into the following formulae to calculate the time to reinforcement for each asset under base and incremental conditions.

$$YearsToReinforcement(base) = \frac{\log(BranchCapacity) - \log(BasePowerFlow(MVA))}{\log(1 + GrowthRate)}$$

$$YearsToReinforcement(inc) = \frac{\log(BranchCapacity) - \log(IncPowerFlow(MVA))}{\log(1 + GrowthRate)}$$

Branch Capacity is the MVA rating of the “critical” asset in the considered Branch divided by the corresponding Security Factor; a pair of Branch capacities is calculated for maximum demand and minimum demand conditions.

3. A single underlying network growth rate is used to assess the timing of future reinforcement for demand and generation charges. It represents the long run growth of all DNO Parties' Distribution Systems and is set to 1% growth per annum.
4. A pair of incremental costs (base and incremental) is calculated for each Branch using the procedure described in this attachment and power flows obtained from Maximum Demand Scenario and Minimum Demand Scenario.
5. Sense checking of the results produced by application of the Security Factor to the Incremented Flow should be undertaken prior to the calculation of Branch incremental cost, to identify where this approach leads to an estimation of excessively large (and non-credible) changes in Branch utilisation. Where such cases are encountered a more reasonable approximation to the anticipated change in power flow in the Branch should be used in the derivation of the Branch incremental cost.
6. It is recommended that a more reasonable approximation to the Branch power flow under incremented conditions should be applied where:-
 - the Base Case Flow (MVA) for a particular Branch is less than a 'low base case powerflow' threshold. This threshold should be defined by examination of the outputs from the power flow analysis, though a threshold of 0.5MVA is suggested as a reasonable 'typical' value; or
 - the Security factor for a particular Branch is greater than 6; or
 - the absolute value of $Flow_Increment > k * Nodal_Increment / Security\ Factor$

Where:-

$Flow_Increment = Incremented\ Flow\ (MVA) - Base\ Case\ Flow(MVA)$

$Nodal_Increment =$ the size of increment applied to the Node in the Incremented Flow Analysis (in MVA); and

k is a factor to take account of losses etc., determined by examining the maximum value of Flow Increment observed in the results from the Incremented Flow Analysis, such that:

$$k = \left[\text{Max.of} \left(\frac{|\text{Flow_Increment}|}{\text{Nodal_Increment}} \right) \right] + 0.5$$

7. Where it is identified that a more reasonable approximation to Branch power flow under incremented conditions should be used, the inputs used in the calculation of 'Years To Reinforcement_(inc)' are adjusted so that they reflect the utilisation of the Branch that would be determined if a power flow equal to ((Base Case Flow * Security Factor) + Flow Increment) were to be compared to the actual Branch rating.

ATTACHMENT 2 - CALCULATION OF PEAK AND OFF-PEAK CHARGES – A SIMPLE EXAMPLE

1. The attachment outlines the calculation of Peak and Off-peak Nodal marginal charges for a simple example shown in Figure 7. The Branch parameters (resistances and reactances), and Branch Ratings (Winter/Summer) given in Figure 7 should be used only for illustrative purposes.
2. The network example shown in Figure 7 represents a single supply point, which supplies two network substations under Normal Running Arrangements. Node A represents a supply point and is modelled as a slack bus.

Figure 7 - Branch reactances, resistances and ratings.

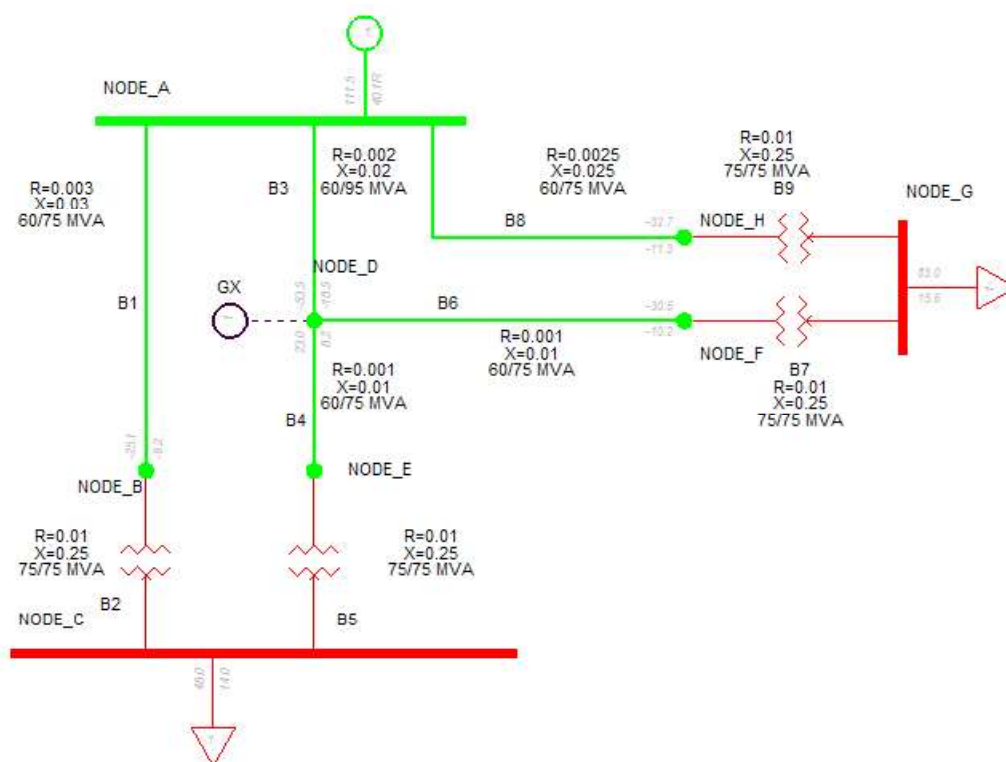

3. Both the Maximum Demand Scenario and Minimum Demand Scenario are analysed in this example.

Base Case Analysis

4. The network model populated with the Maximum Demand Data is represented by a load of 48MW and 14MVA_r modelled at Node C and a load of 63MW and 15.8MVA_r

modelled at Node G. The generator connected to Node D does not export any MW/MVAr to the network. The Base Case Flows are shown in Figure 8.

- The network model is populated with the Minimum Demand Data by the application of an appropriate Scaling Factor to demand (load) connected to the Nodes. The generator connected to Node exports 5.0 MW and 2.0 MVAr in the network The Base Case Flows are shown in Figure 9.

Figure 8 - Base Case Flows- Maximum Demand Scenario.

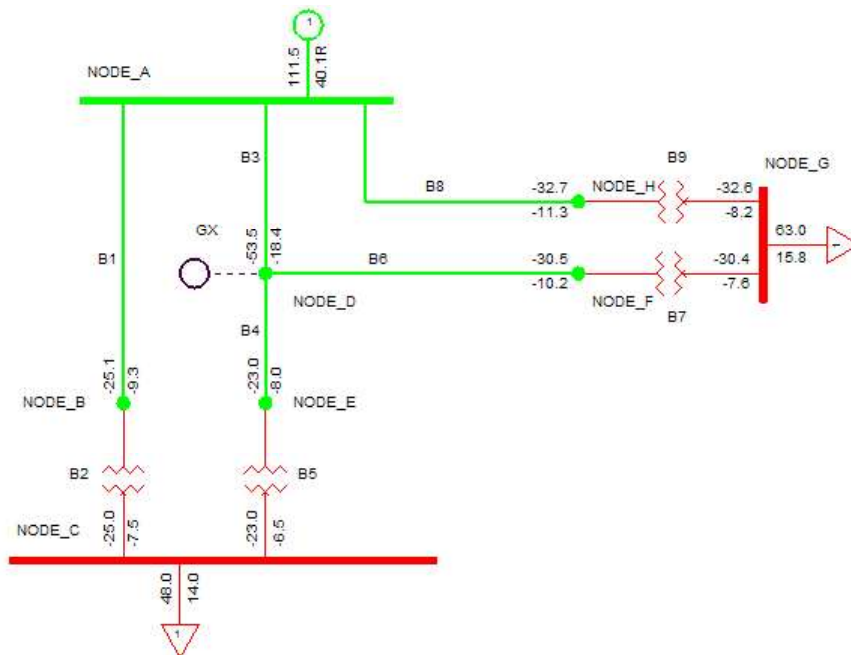
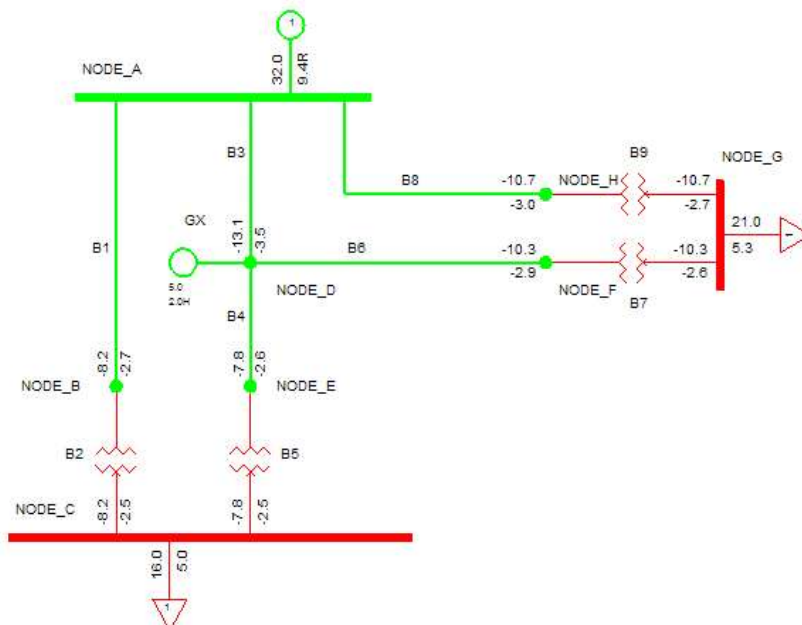

Figure 9 - Base Case Flows- Minimum Demand Scenario.



Contingency Analysis

6. The Contingency Analysis focuses on three contingencies only. The post-contingent flows are given in **Figure 10**, **Figure 11**, and **Figure 12** for the Maximum Demand Scenario and in **Figure 13**, **Figure 14**, and **Figure 15** for the Minimum Demand Scenario. The dashed line shows the Branches that are subject to the outage.

Figure 10 - Maximum Demand Scenario - Contingency Case 1.

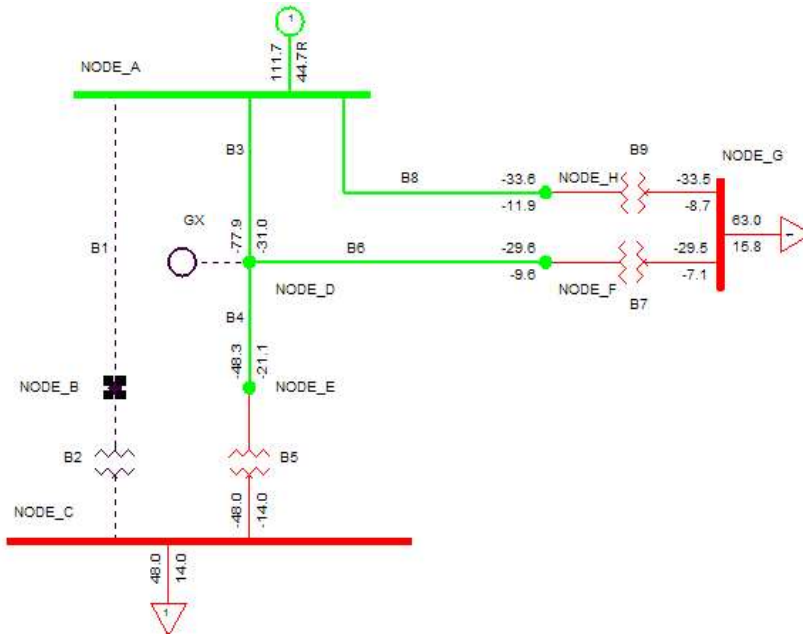

Figure 11 - Maximum Demand Scenario - Contingency Case 2.

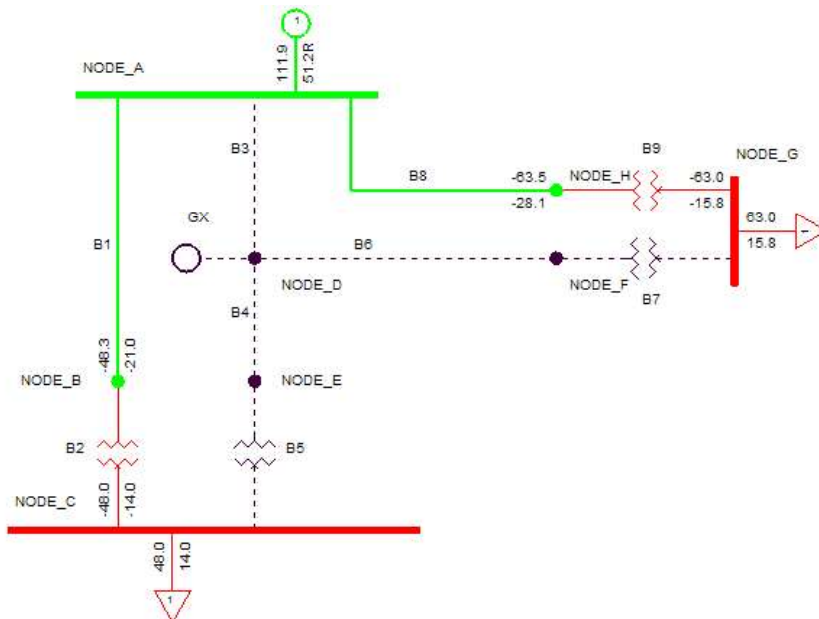

Figure 12 - Maximum Demand Scenario - Contingency Case 3.

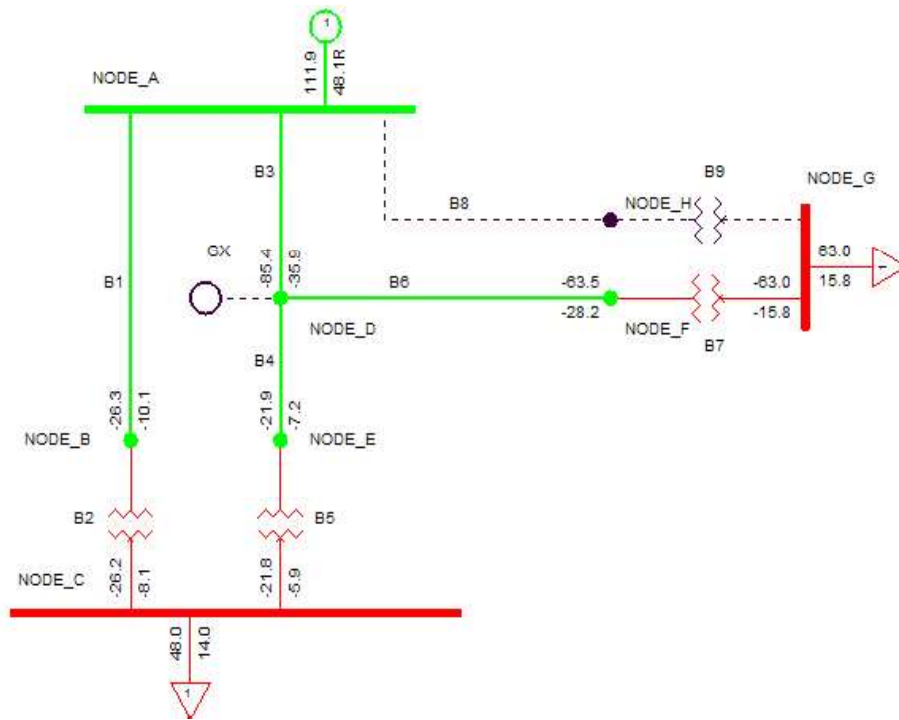

Figure 13 - Minimum Demand Scenario - Contingency Case 1.

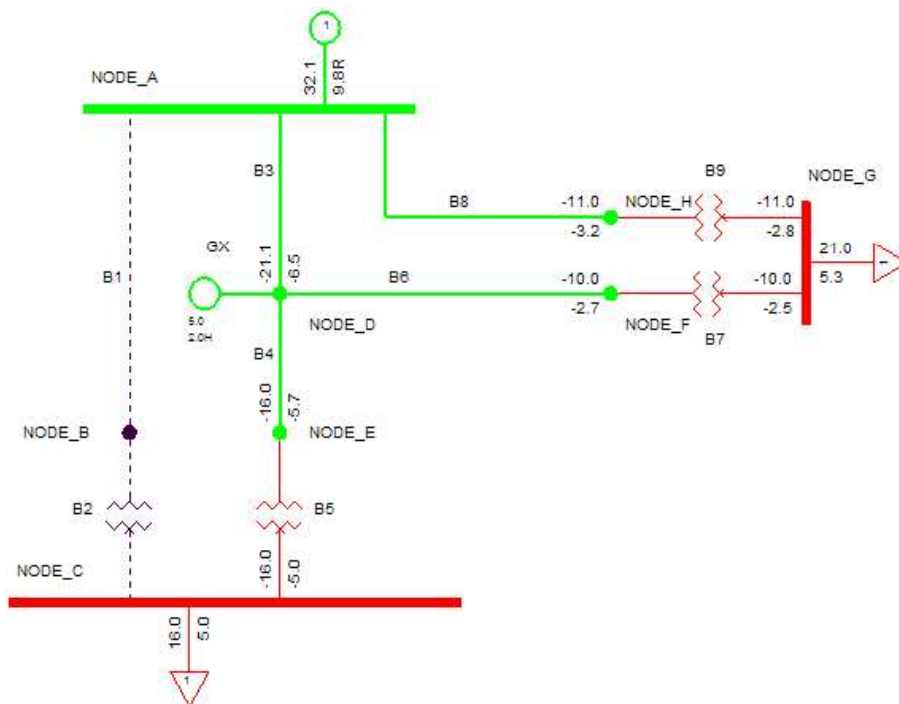

Figure 14 - Minimum Demand Scenario - Contingency Case 2

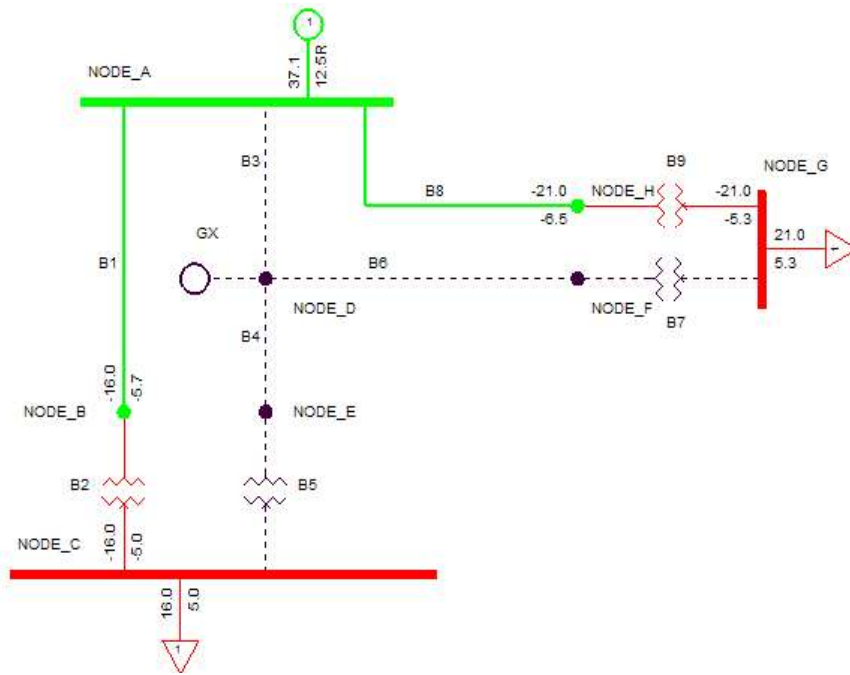
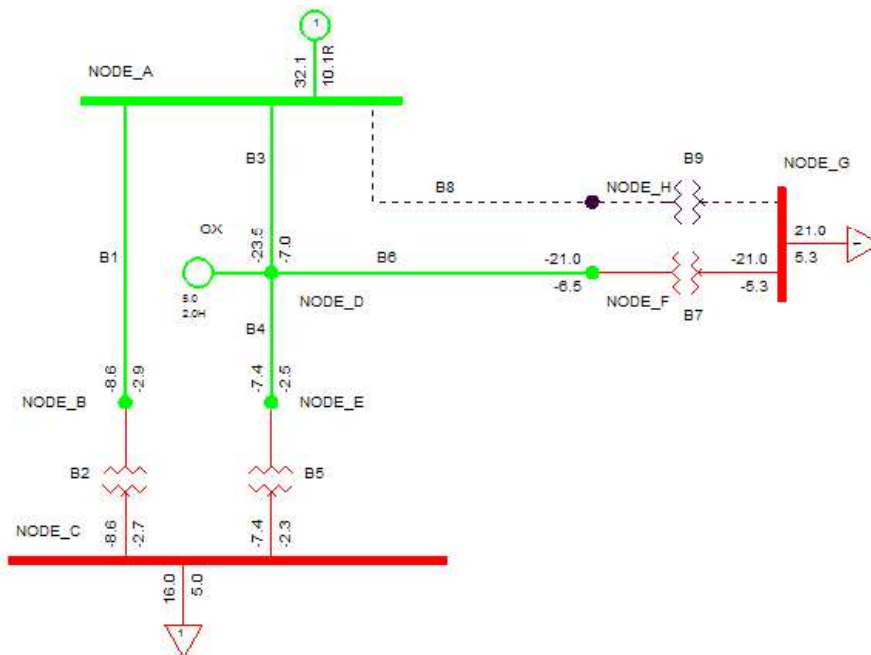

Figure 15 - Minimum Demand Scenario - Contingency Case 3.



7. The calculation of Security Factors is summarised in Table 7 and Table 7A for the Maximum Demand Scenario and Minimum Demand Scenario, respectively. Each table contains information (for all Branches and both Maximum Demand and Minimum Demand Scenario) related to:
- Base Case Flows.
 - Maximum Contingency Flow.
 - Security Factor which is a ratio of Maximum Contingency Flow and Base Case Flow.
 - Contingency Case referring to the contingency case that causes the Maximum Contingency Flow.
 - Branch Winter/Summer Rating.
 - Branch Capacity which is a ratio of the corresponding Branch Rating and Security Factor.
 - Years to Reinforcement (base) - which is a year when the corresponding Branch will reach its Branch Capacity assuming annual Branch flow growth of 1% based on an exponential growth function. For, example Branch B5 will reach its Branch Capacity after 35.49 years for Maximum Demand Scenario because:

- $34.70 = 24.38 * (1 + 0.01)^{35.49}$

Table 7 - Calculation of Maximum Contingency Flow, Security Factors and Years to Reinforcement (Base Case) - Maximum Demand Scenario.

Branch	Base Case Flows (MVA)	Maximum Contingency Flow(MVA)	Security Factor	Contingency Case	Winter Rating (MVA)	Branch Capacity (MVA)	Years to Reinforcement (base)
B5	24.38	52.69	2.16	1	75.00	34.70	35.49
B9	34.60	69.42	2.01	2	75.00	37.38	7.78
B1	26.85	53.01	1.97	2	75.00	37.99	34.88
B3	56.87	93.46	1.64	3	95.00	57.81	1.64
B8	34.72	70.03	2.02	2	75.00	37.19	6.89
B2	26.77	52.66	1.97	2	75.00	38.13	35.54
B4	24.40	52.83	2.16	1	75.00	34.64	35.22
B6	32.20	69.66	2.16	3	75.00	34.66	7.42
B7	32.16	69.46	2.16	3	75.00	34.73	7.72

Table 7A - Calculation of Maximum Contingency Flow, Security Factors and Years to Reinforcement (Base Case) - Minimum Demand Scenario.

Branch	Base Case Flows (MVA)	Maximum Contingency Flow(MVA)	Security Factor	Contingency Case	Summer Rating (MVA)	Branch Capacity (MVA)	Years to Reinforcement (base)
B5	8.25	17.02	2.06	1	75.00	36.35	149.04
B9	11.12	22.04	1.98	2	75.00	37.86	123.10
B1	8.65	17.06	1.97	2	60.00	30.41	126.39
B3	13.62	24.58	1.80	3	60.00	33.25	89.70
B8	11.13	22.08	1.98	2	60.00	30.25	100.45
B2	8.64	17.02	1.97	2	75.00	38.05	149.04
B4	8.25	17.03	2.06	1	60.00	29.07	126.54
B6	10.72	22.05	2.06	3	60.00	29.16	100.58
B7	10.71	22.04	2.06	3	75.00	36.46	123.09

Incremented Flow Analysis

8. The Incremented Flow Analysis needs to be carried out once the Branch Capacity and Security Factors are determined. For the network example used in this attachment six power flow studies are required to determine the Incremented Flows. These studies are listed in table 8.

Table 8 - Incremented Flow Analysis – Studies

Study	Type of Demand at Node Being Incremented	Increment Applied			
		Maximum Demand Scenario		Minimum Demand Scenario	
		Power Factor	Direction	Power Factor	Direction
1-2	Node G Demand	0.95	Load	0.95	Generation
3-4	Node C Demand	0.95	Load	0.95	Generation
5-6	Node D Generation	Unity	Load	Unity	Generation

9. For example, two studies are required to assess the impact of the increments applied to Node G. For Maximum Demand Scenario an increment of 0.1 MW at 0.95 power factor would be applied in the load direction, while for Minimum Demand Scenario the same increment would be applied but in the generation direction. The Incremented Flows for both studies are shown below (Figure 16 and Figure 17).

Figure 16 - Node G incremented power flow analysis for Maximum Demand Scenario.

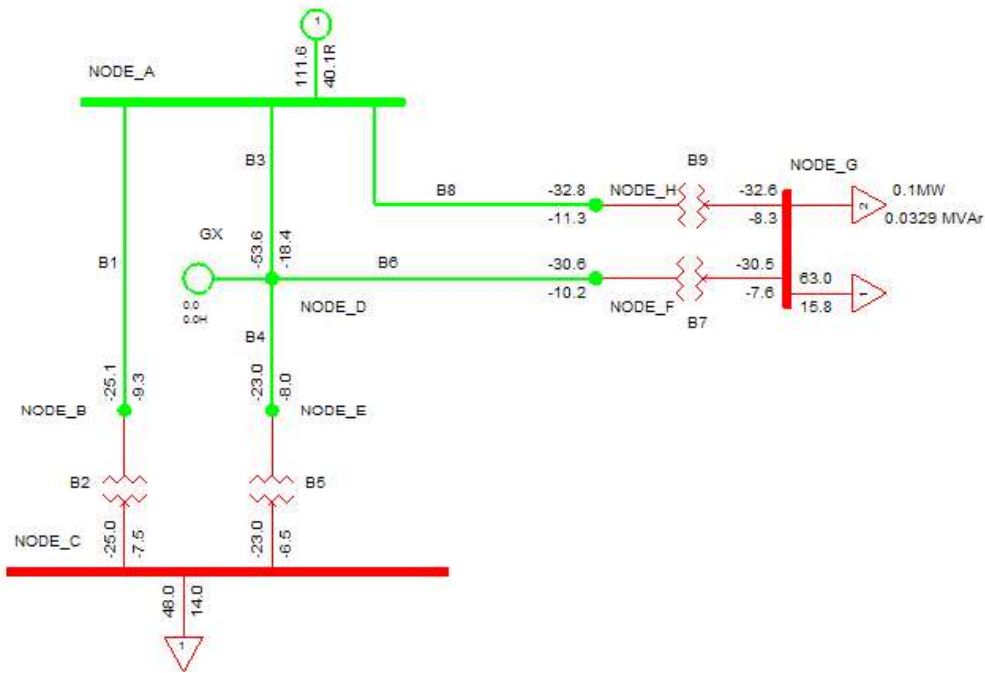
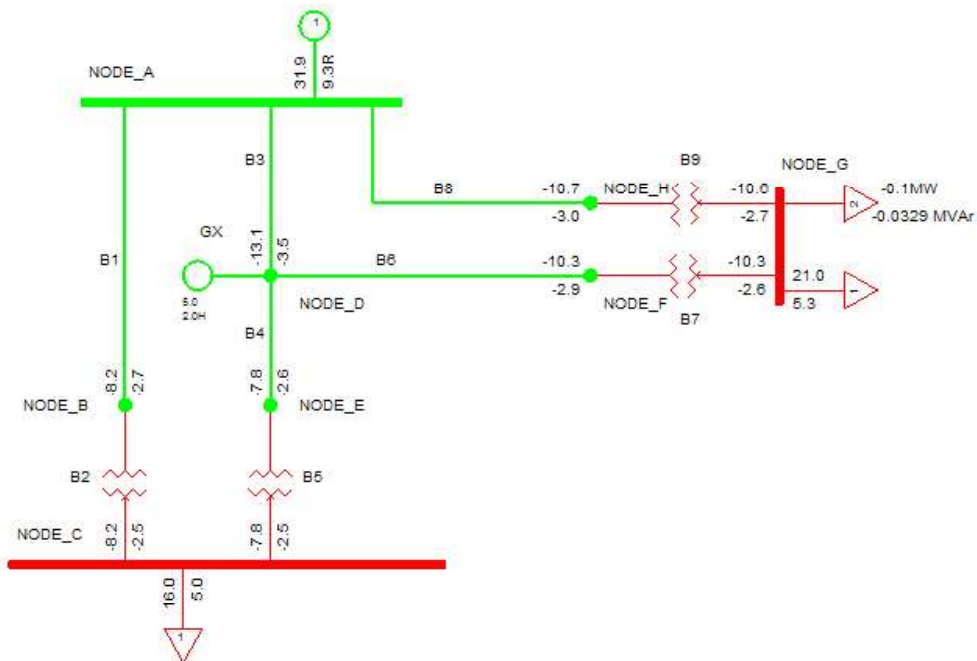

Figure 17 - Node G incremented power flow analysis for Minimum Demand Scenario.



- Using the following Table 10 of Branch reinforcement cost and the algorithm in Attachment 1, Branch incremental cost is calculated for both Maximum and Minimum Demand Scenarios. The critical scenario that drives the Branch reinforcement is then identified as the scenario with the highest absolute value of associated Branch

incremental cost. For example, for Branch i , if $|\Delta C_i^{peak}| > |\Delta C_i^{off-peak}|$, the scenario that drives the reinforcement of the Branch is Peak; otherwise it is Off-Peak.

Table 10 - Branch Reinforcement Cost

Branch	Reinforcement Cost (£)
B1	1156250
B2	946500
B3	2312000
B4	1156250
B5	946500
B6	2312000
B7	946500
B8	1156250
B9	946500

11. Summaries of the Incremented Flow Analysis and the Branch incremental cost calculation are given in Table 14. The following columns are given in the table:
- (1) Generation/Demand identifier.
 - (2) Node where the corresponding increment was applied.
 - (3) Branch ID – only for Branches which kVA flow increment is larger than 1 kVA and 0.01% of the Base Case Flow.
 - (4) Base Case Flow (MVA) of the Branch for the scenario that drives reinforcement of the Branch. The scenario (either Maximum Demand Scenario-Peak, or Minimum Demand Scenario -Off-Peak) that drives reinforcement of the Branch is the one with the highest absolute value of associated Branch incremental cost.
 - (5) Branch Capacity (MVA) of the Branch (see previous section – Contingency Analysis).

- (6) Branch Incremented Flows (MVA) for the scenario that drive reinforcement of the Branch.
- (7) Years to Reinforcement (base) in years - is the time to reinforcement of the Branch calculated under Base Case conditions as discussed in the previous section (see previous section – Contingency Analysis).
- (8) Years to Reinforcement (inc) in years - is the time to reinforcement of the Branch calculated under incremental conditions as discussed in Attachment 1 above.
- (9) A product of Net Present Value (base) and annuity rate for the scenario that drives reinforcement of the Branch.
- (10) A product of Net Present Value (inc) and annuity rate for the scenario that drives reinforcement of the Branch.
- (11) Branch incremental cost ΔC_i is the difference between the values given in the columns 10 and 9.
- (12) The last column identifies the scenario that drives the reinforcement of the Branch.
12. Using the information provided in Table 14 the Peak Nodal incremental cost and Off-Peak Nodal incremental cost for the generator connected to Node D can be calculated:
- The Peak Nodal incremental cost is the sum of 294.87, -1278.73 and -328.68 which gives the total of -1312.54 £/annum.
 - The Off-Peak Nodal incremental cost is the sum of all Off-Peak Branch incremental costs which is -18.77 £/annum.
13. For the demand located at Node C the corresponding costs are the sum of all Peak Branch incremental costs which based on Table 14 the Peak Nodal incremental cost and Off-Peak Nodal incremental cost for the generator connected to Node D can be calculated: Table 21 gives 2777.8 £/annum; and the sum of all Off-Peak Branch incremental costs which gives -10.52 £/annum.
14. The Nodal marginal charges are obtained by dividing the Nodal incremental cost by the magnitude (in kVA) of the load or generation increment, as appropriate.

Table 14 - Incremented flow analysis

Gen/Dem	At Node	Branch	Base Case Flow (MVA)	Asset Capacity (MVA)	Incremented Flow (MVA)	Years to Reinf. (base)	Years to Reinf. (inc)	NPV* Annuity Rate (base) (£/annum)	NPV* Annuity Rate (inc) (£/annum)	ΔC_i (£/annum)	Peak Off-peak
Gen	Node D	B5	24.38	34.70	24.54	35.48	34.83	6576.14	6871.01	294.87	Peak
Gen		B9	34.6	37.38	34.44	7.77	8.24	41784.75	40506.03	-1278.73	Peak
Gen		B1	26.85	37.99	26.69	34.87	35.47	8366.34	8037.65	-328.68	Peak
Gen		B3	13.62	33.25	13.53	89.69	90.35	431.65	412.88	-18.77	Off-peak
Dem	Node C	B5	24.38	34.70	24.60	35.48	34.58	6576.14	6984.45	408.32	Peak
Dem		B9	34.6	37.38	34.44	7.77	8.24	41784.75	40506.03	-1278.73	Peak
Dem		B1	26.85	37.99	26.74	34.87	35.29	8366.34	8139.17	-227.17	Peak
Dem		B3	13.62	33.25	13.57	89.69	90.06	431.65	421.13	-10.52	Off-peak
Dem		B8	34.72	37.18	34.56	6.89	7.35	54128.66	52477.83	-1650.84	Peak
Dem		B2	26.77	38.13	26.66	35.54	35.95	6551.07	6372.66	-178.41	Peak
Dem		B4	24.4	34.64	24.63	35.22	34.27	8177.67	8708.68	531.01	Peak
Dem											

Dem		B6	32.2	34.67	32.37	7.42	6.89	104456.61	108210.81	3754.20	Peak
Dem		B7	32.16	34.73	32.32	7.71	7.21	41946.47	43365.89	1419.42	Peak
Dem	Node G	B5	24.38	34.70	24.35	35.48	35.61	6576.14	6522.07	-54.07	Peak
Dem		B9	34.6	37.38	34.69	7.77	7.51	41784.75	42519.02	734.26	Peak
Dem		B1	26.85	37.99	26.77	34.87	35.17	8366.34	8200.59	-165.74	Peak
Dem		B3	13.62	33.25	13.56	89.69	90.13	431.65	419.05	-12.59	Off-peak
Dem		B8	11.13	30.24	11.11	100.47	100.65	105.15	103.89	-1.26	Off-peak
Dem		B4	24.4	34.64	24.35	35.22	35.42	8177.67	8065.96	-111.72	Peak
Dem		B6	10.72	29.17	10.70	100.60	100.79	208.35	205.76	-2.59	Off-Peak
Dem		B7	32.16	34.73	32.25	7.71	7.43	41946.47	42739.94	793.47	Peak

ATTACHMENT 3 - OUTPUT RESULTS

1. The final output of the work outlined in this Schedule 18 are Peak and marginal charges in £/kVA/annum. This is not however the final EDCM Use of System Charge and further calculations under EDCM are required to derive this final charge.
2. The output data listed in table 3 below are the minimum necessary for the calculation of the final EDCM Use of System Charges. For each Node where demand or generation is located a single pair of charges is required. For a Node where both demand and generation are located a double pair of charges is required (there will be two entries where 'Node ID' would be the same but all other values would be different).
3. The outputs from the Power Flow Analysis, the Branch Rating Data and the network cost data (see Figure 5) will also be retained in the interests of transparency.

Table 3 - Output information required to calculate final EHV charge

Item Name	Details
Location ID	Unique identifier of the Node.
Demand Type ID	Identifier for the type of demand (either 'Demand' or 'Generation')
Local Charge 1: Local Element of Peak Charge (£/kVA/annum)	See the Output results Section. A positive value of Peak Charge represents a charge to demand (load) at the Node (or a credit to generation), whilst a negative value represents a credit to demand (load) at the Node (or a charge to generation)
Remote Charge 1: Remote Element of Peak Charge (£/kVA/annum)	See the Output results Section. A positive value of Peak Charge represents a charge to demand (load) at the Node (or a credit to generation), whilst a negative value represents a credit to demand (load) at the Node (or a charge to generation)
Active power (kW) for Maximum Demand Scenario.	For a Node where demand (load) is located this would be the total kW demand (load) connected to the Node (negative value) in the Maximum Demand Scenario. For a Node where a generator is located this would be the total kW generation connected to the Node (positive value) in the Maximum Demand Scenario.

Reactive power (kVAr) for Maximum Demand Scenario.	For a Node where demand (load) is located this would be the total kVAr demand (load) connected to the Node in the Maximum Demand Scenario. For a Node where a generator is located this would be the total kVAr generation connected to the Node in the Maximum Demand Scenario. ²⁰
----------------------------------------------------	------------------------------------------------------------------------------------------------------------------------------------------------------------------------------------------------------------------------------------------------------------------------------------------------

²⁰ Where the current calculated for demand lags its voltage the reactive power shall be allocated the same sign as the active power. Where the current calculated for demand leads its voltage the reactive power shall be allocated the opposite sign to the active power.

SCHEDULE 18 – EHV CHARGING METHODOLOGY (LRIC MODEL)

ANNEX 2 – DERIVATION OF THE LRIC CHARGING FORMULA

The essential concept of the LRIC charging model is one of marginal pricing which is applicable to competitive markets. At the equilibrium point of supply and demand the clearing price in £/unit, being the cost (£) of producing another unit of output, is the economically efficient price because producers and consumers know this cost and can adjust their behaviour. The concept is illustratively shown in Figure 18 through definitions of *marginal* and *incremental* costs. Assuming a non-linear cost-demand curve, where demand can be either load or generation, marginal cost is the first derivative at the point (D^0, C^0) and it is denoted as $tg\beta$ in Figure 18(a). Marginal cost is calculated analytically when the non-linear cost-demand relationship is known and is in explicit form. In many instances, and in particular when the non-linear relationship is very complex or specified implicitly, it is preferable to calculate the first derivative in a numerical way using finite increments, which gives the incremental cost – Figure 18(b). Given the current point (D^0, C^0) , demand is incremented by ΔD first, new cost $(C^0 + \Delta C)$ is calculated from the cost curve next and the ratio of ΔC to ΔD gives the incremental cost $tg\gamma$. The smaller the increment ΔD , the closer the incremental cost to the marginal cost is.

Figure 18 - Concept of marginal (a) and incremental costs (b)

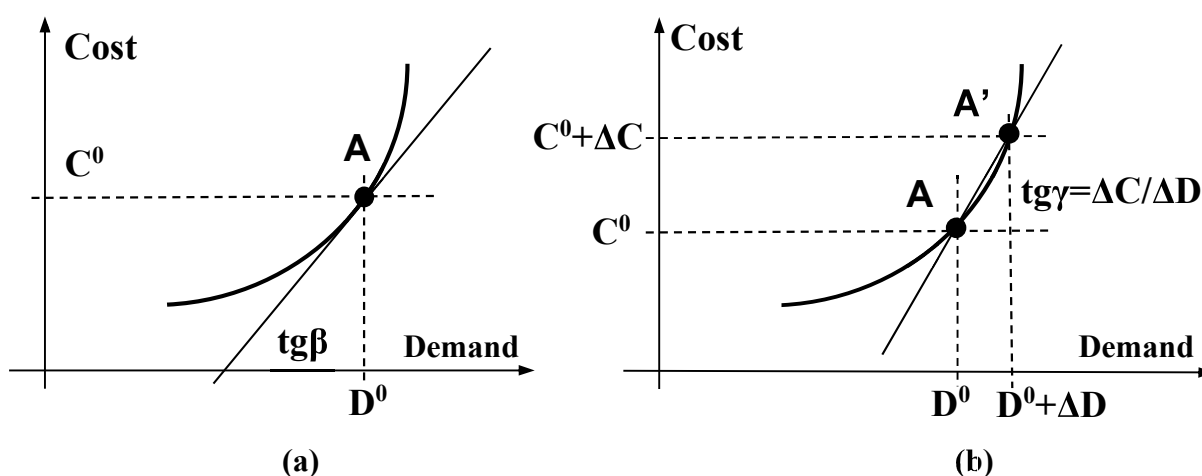

The LRIC cost model is specified on a Branch-by-Branch basis, that is, a cost expression is associated with each Branch of the network. The Branch cost is the annuitised NPV reinforcement cost, or in mathematical terms:

$$BranchCost_i = NPV_i \cdot AnnuityRate = \frac{CostOfReinforcementSolution_i}{(1+DiscountRate)^{YearsToReinforcement_i()}} \cdot AnnuityRate \text{£/annum}$$

where i is index of Branch, NPV_i is present value of the Branch cost

$CostOfReinforcementSolution_i$ discounted at rate $DiscountRate$ specified by regulator, $YearsToReinforcement_i()$ is time in future when reinforcement of $Branch_i$ will be required if the power flow grows at the given rate, and $AnnuityRate$ is the standard annuity factor calculated from the discount rate and annuity period. It needs to be stressed that the only quantity that depends on Connectees' demands (both load and generation) is time to reinforcement $YearsToReinforcement_i()$, the others are constants.

Branch marginal cost is the first derivative of the Branch cost (1) with respect to demand (either load or generation) connected at any Node k . As $YearsToReinforcement_i()$, in expression (1) is a function of the power flow in Branch i , which is in turn a function of all demands D_k , $k=1,2,\dots$, the chain rule needs to be applied to derive expression (1):

$$BranchMarginalCost_i^k = \frac{\partial BranchCost_i}{\partial D_k} = \frac{\partial BranchCost_i}{\partial YearsToReinforcement_i} \frac{\partial YearsToReinforcement_i}{\partial flow_i} \frac{\partial flow_i}{\partial D_k} \text{£/kVA/annum},$$

where D_k is demand at Node k and $flow_i$ is power flow in $Branch_i$.

The corresponding incremental cost is, in a similar way, given by expression:

$$BranchIncrementalCost_i^k = \frac{\Delta BranchCost_i}{\Delta D_k} = \frac{\Delta BranchCost_i}{\Delta YearsToReinforcement_i} \frac{\Delta YearsToReinforcement_i}{\Delta flow_i} \frac{\Delta flow_i}{\Delta D_k} \text{£/kVA/annum}.$$

It is also possible to apply an alternative approach to calculate Branch incremental cost. The finite differences are applied to $BranchCost_i$ and $YearsToReinforcement_i()$, and the first derivative to $flow_i$

$$BranchIncrementalCost_i^k = \frac{\Delta BranchCost_i}{\Delta D_k} = \frac{\Delta BranchCost_i}{\Delta YearsToReinforcement_i} \frac{\Delta YearsToReinforcement_i}{\Delta flow_i} \frac{\partial flow_i}{\partial D_k} \text{£/kVA/annum},$$

where partial derivative $\frac{\partial flow_i}{\partial D_k}$ is calculated analytically.

The main algorithmic steps to calculate Branch incremental cost (3) or (4) are given below:

1. (Base Power Flow) Set all demands (i.e. loads and generations) to the base values and calculate base power flow in the considered Branch $BasePowerFlow_i(MVA)$ using the full AC powerflow model.
2. (Base Branch Cost) From the base power flow $BasePowerFlow_i(MVA)$, Branch i capacity (MVA) and assumed exponential power flow growth calculate base time to reinforcement $YearsToReinforcement_i(base)$ and then base Branch cost $BranchCost_i(base)$ in £/annum with the aid of expression (1).
 - 3.1 (Incremented Power Flow - expression (3)) Increment demand at Node k by ΔD_k and recalculate power flows using the AC power flow model. This gives incremented power flow in the considered Branch $IncPowerFlow_i(MVA)$.
 - 3.2 (Incremented Power Flow - expression (4)) Calculate analytically from the AC powerflow model sensitivity coefficient $s_i^k = \partial flow_i / \partial D_k$ giving the linearised relationship between power flow in Branch i and demand at Node k . The incremented power flow in the considered Branch is:

$$IncPowerFlow_i(MVA) = BasePowerFlow_i(MVA) + s_i^k \cdot \Delta D_k. \quad (5)$$

4. (Incremented Branch Cost) from the incremented power flow $IncPowerFlow_i(MVA)$, Branch i capacity (MVA) and assumed exponential power flow growth calculate incremented time to reinforcement $YearsToReinforcement_i(inc)$ and then incremented Branch cost $BranchCost_i(inc)$ in £/annum with the aid of expression (1).
5. (Branch Incremental Cost) Branch incremental cost in £/annum is finally calculated as:

$$BranchIncrementalCost_i^k = BranchCost_i(inc) - BranchCost_i(base) \text{ £/annum}, \quad (6)$$

Demand Connectees (both load and generation) use several Branches to offtake their load or inject the generation. These Branches can be identified by the magnitude of the incremented power flow

$$\Delta flow_i (= IncPowerFlow_i(MVA) - BasePowerFlow_i(MVA))$$

The Branch incremental costs of these Branches need to be summated in order to calculate the incremental cost for a Connectee connected at any Node. More specifically, assuming a single operating regime is studied, the LRIC charging formula for the demand Connectee (either load or generation) connected at Node k becomes:

$$NodalIncrementalCost_k = \sum_i BranchIncrementalCost_i^k \text{ £/annum}, \quad (7)$$

where summation goes over “relevant” network Branches, that is, Branches which are used by the considered Connectee.

Finally, Nodal marginal charges are derived by dividing the Nodal incremental cost by the assumed demand increment:

$$ChargeAtNode_k = \frac{NodalIncrementalCost_k}{\Delta D_k} \text{ £/kVA/annum},$$

where ΔD_k is assumed demand increment at $Node_k$